

# 40 SERIE TANDEM GEAR PUMPS ASAE SHORT SHAFT

## 40 SERİ TANDEM ASAE KISA MİL DİŞLİ POMPALAR



Inlet Pressure	0.3÷ 2 bar		
Operating Viscosity	-12:100 cSt		
Fluid Temperature	-40 °C+145 °C		
Working Pressure	Contamination		Filtre
	NAS 1638	ISO 4406	$\beta_x=75$
$\geq 200$ bar	11	20/17	25 $\mu$ m
$\leq 200$ bar	12	21/18	40 $\mu$ m

40 SERIES GEAR PUMPS  
40 SERİSİ DİŞLİ POMPALAR

HYDRAULIC PUMPS  
HİDROLİK POMPALAR

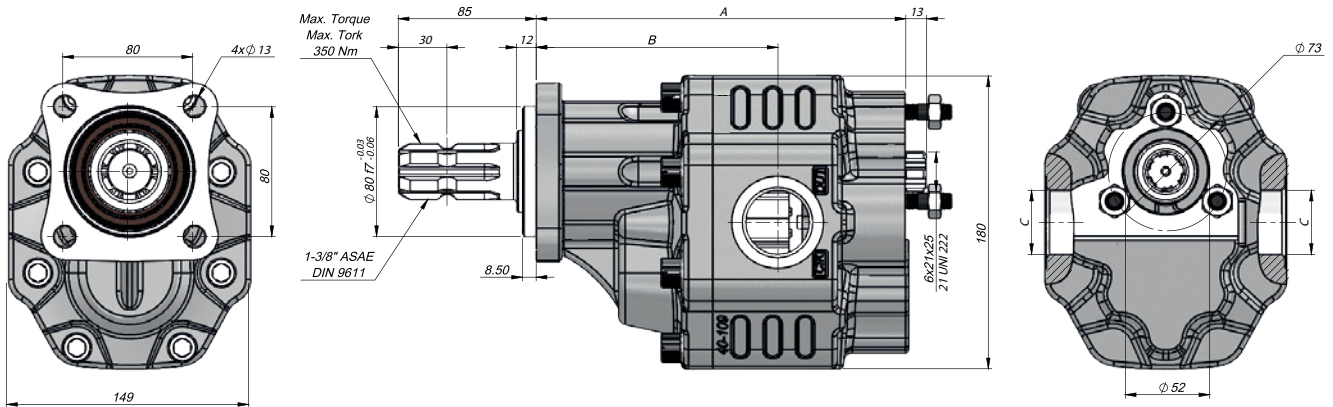

Code			Displacement	Max. Continuous Pressure	Min. Speed	Max. Continuous Speed	A	B	Inlet	Outlet
Left	Right	Bi-Rotational	(cm <sup>3</sup> /rev)	(%100) (BAR)	(RPM)	(RPM)	(mm)	(mm)	C	D
34206312TAN	43206311TAN	340063AS231	63	290	300	1800	211	139	G 1 1/4"	G 3/4"
34207312TAN	43207311TAN	340073AS231	73	280			215	139		
34208712TAN	43208711TAN	340087AS231	87	260			220	143		
34210912TAN	43210911TAN	340109AS231	109	250			228	149	G 1 1/2"	
34213312TAN	43213311TAN	340133AS231	133	220			237	150		
34215112TAN	43215111TAN	340151AS231	151	180			243	152,5		

\*The values in the table refer to unidirectional pumps. Reversible pump max pressures are 10% lower than those shown in table. For different working conditions please consult our sales department.