

6 5 4 3 2 1

D

C

B

A

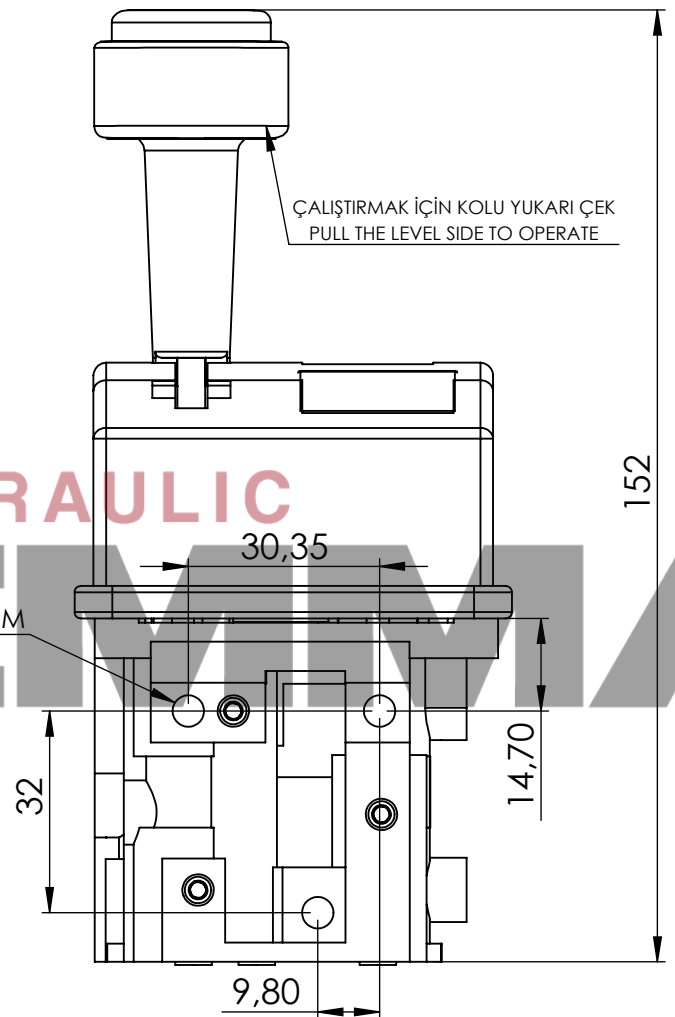
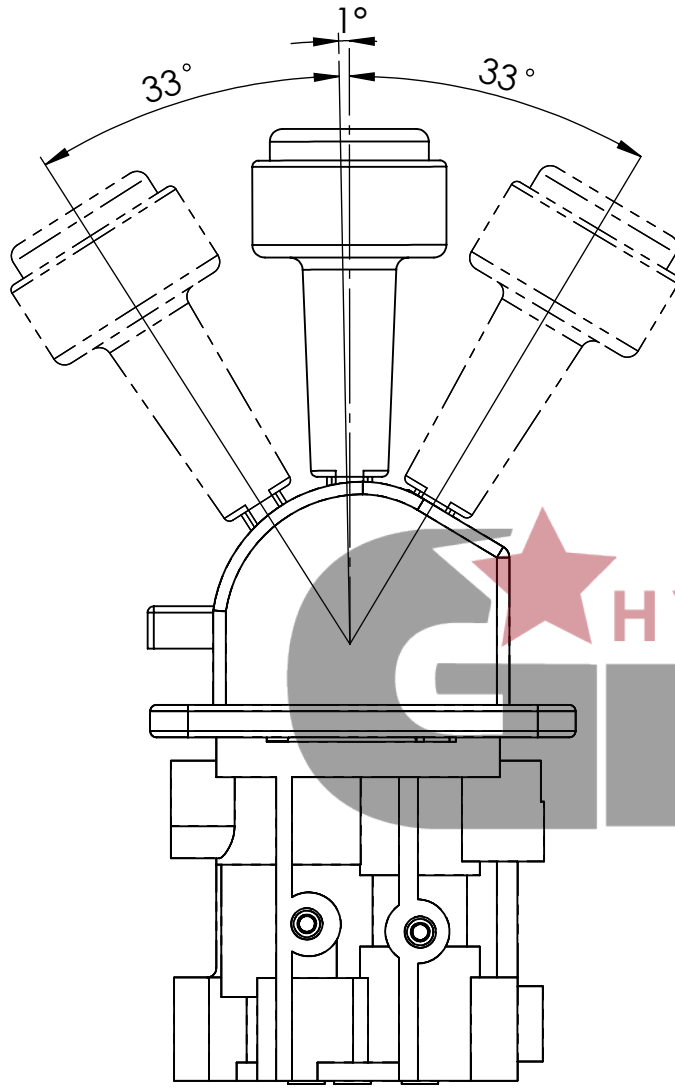

D

C

B

A

ÇİZEN DRAWN	MALZEME MATERIAL	TAŞLAMA GRINDING		STOK KODU/STOCK KODE	ÖLÇEK:1:2
KONT. CHECKED	AĞIRLIK WEIGHT	ISIL İŞLEM HEAT TREAT			
TARİH DATE	KAPLAMA COATING	SATIN ALMA BUY		SAYFA 1 / 1	A4
CNC KOD CNC CODE	OP KODU OP CODE	UNDER OTHERWISE SPECIFIED DIMENSIONS ARE IN MILLIMETRES			

6 5 4 3 2 1