

6

5

4

3

2

1

D

D

C

C



B

B

A

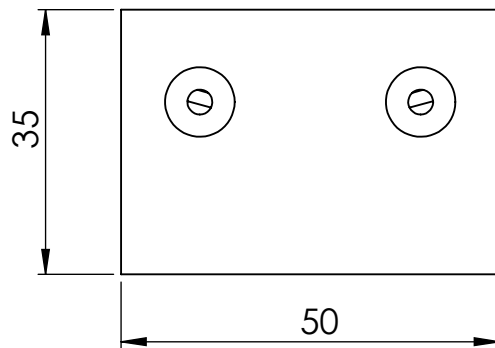
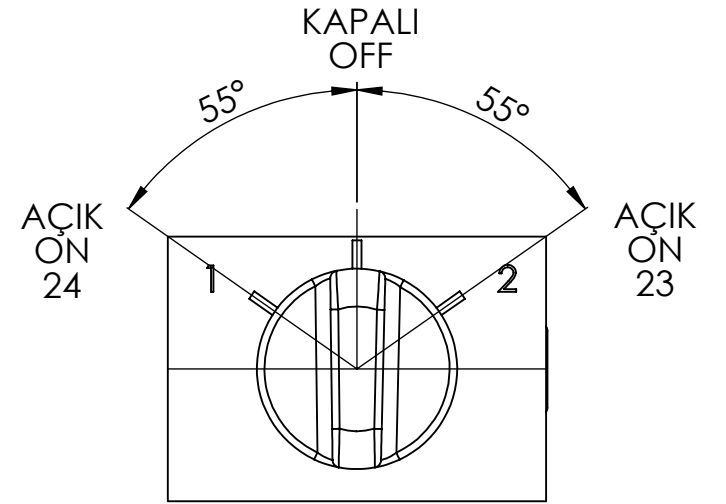
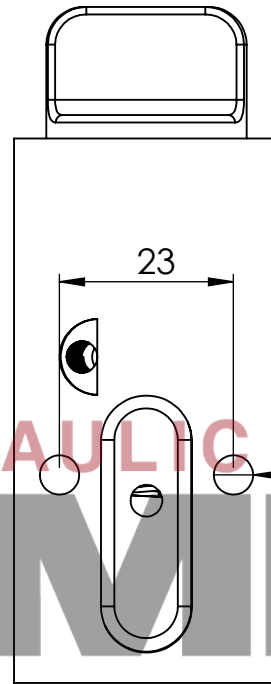
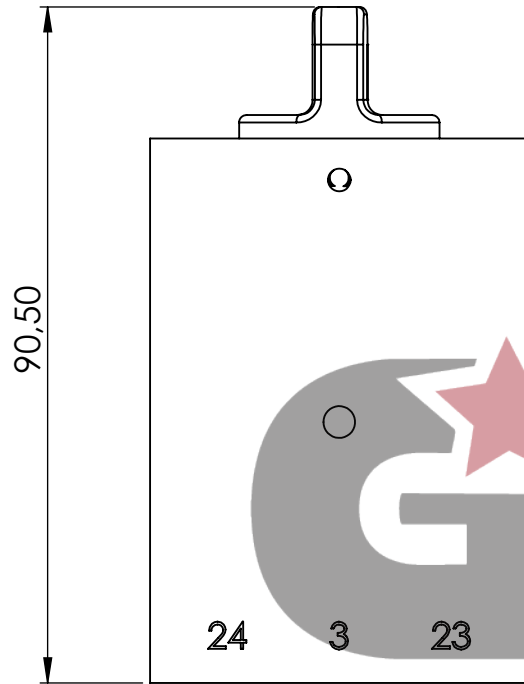
A



ÇİZEN DRAWN		MALZEME MATERIAL		TAŞLAMA GRINDING		HYDRAULIC GEMMA	STOK KODU/STOCK KODE	ÖLÇEK:1:2 SAYFA 1 / 1 A4
KONT. CHECKED		AĞIRLIK WEIGHT		ISIL İŞLEM HEAT TREAT				
TARİH DATE		KAPLAMA COATING		SATIN ALMA BUY				
CNC KOD CNC CODE		OP KODU OP CODE		 TOLERANCES	 UNDER OTHERWISE SPECIFIED DIMENSIONS ARE IN MILLIMETRES			

6

5

4

3

2

1