

# EATON 4106 HELIX SIDE UNI

## EATON 4106 HELİS YAN UNI

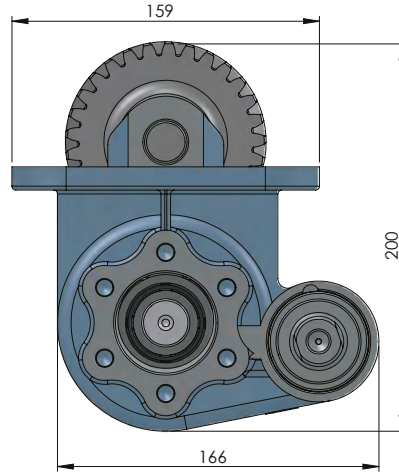
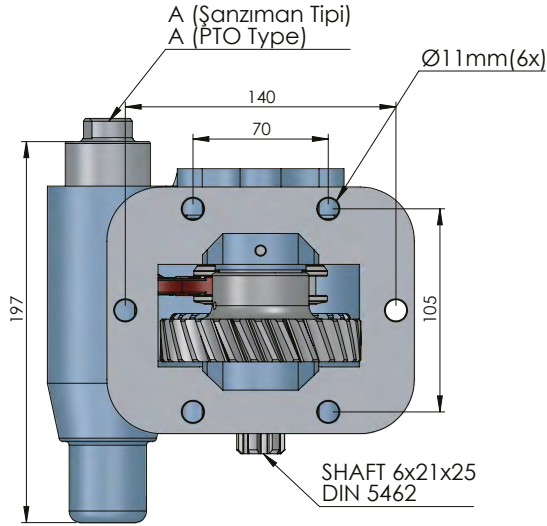
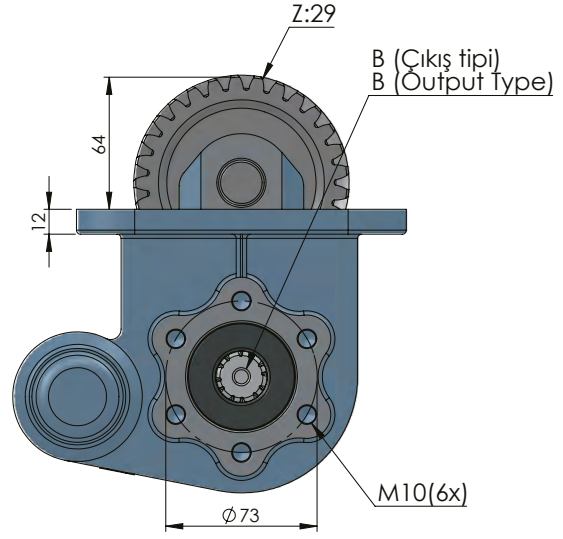

CODE KOD	TYPE TİP (A)	MOUNTING TYPE BAĞLANTI TİPİ (B)	MOUNTING SIDE BAĞLANTI	TORQUE TORK (Kgm / Nm)	POWER GÜÇ (Hp / Kw)	SPEED DEVİR (RPM)	RATIO ORAN
50412512P0	PNEUMATIC PNÖMATİK	UNI	SIDE YAN	25 Kgm 245 Nm	26,8 HP 20 Kw	750 RPM	1/1,16
50412522P0		ISO ADAPTER ADAPTÖRLÜ ISO					
50412532P0		FLANGE FLANŞLI					
50412542P0		SHAFT ŞAFTLI					
GEARBOX / ANA ŞANZIMANLAR				USED VEHICLES / KULLANILAN BAZI ARAÇLAR			
PTO EATON FS/FS0/H/V 4106-5206 A/B/H				180-617-620-622 BMC PRO / 200.26-180 FATİH BMC2520 FORD CARGO / AS 950 / CHRYSLER 180.12-210-220 CD-320 MIDLUM RENAULT / FODEN 2000 / ERF E6.18 / 1415-1718 FORD 8.163- 8.224-18-224 MAN/ FEDON ATKINSON E6.11 /			