

EATON 4106 SIDE UNI

EATON 4106 YAN UNI

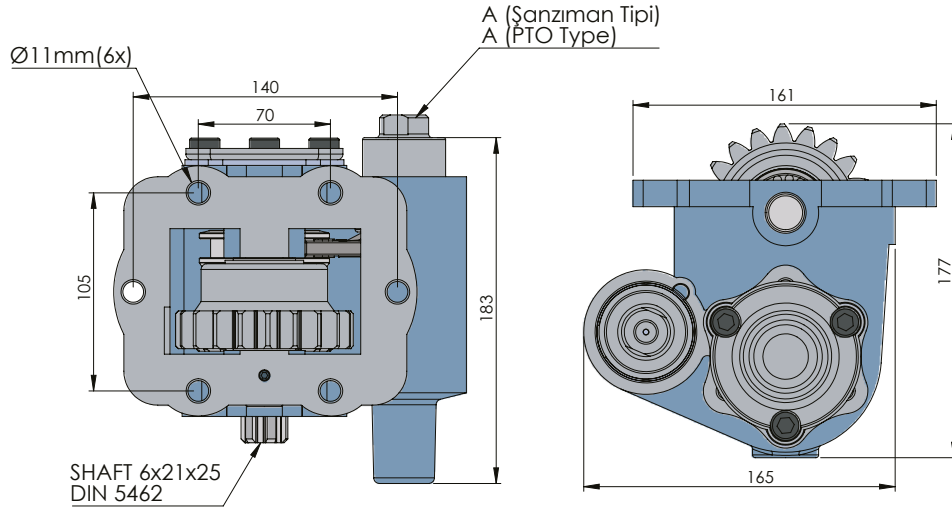
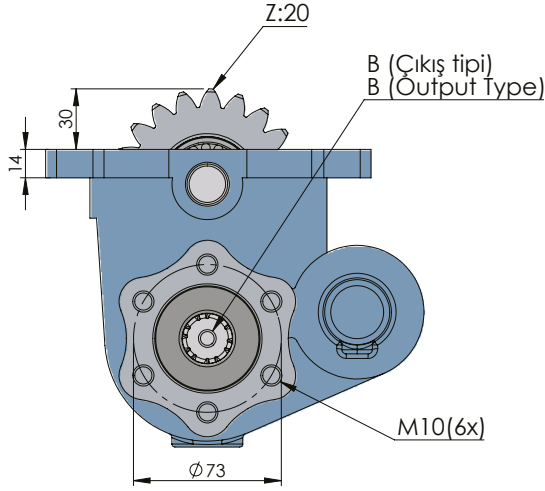

EATON

POWER TAKE-OFFS
P.T.O.

CODE KOD	TYPE TİP (A)	MOUNTING TYPE BAĞLANTI TİPİ (B)	MOUNTING SIDE BAĞLANTI	TORQUE TORK (Kgm / Nm)	POWER GÜÇ (Hp / Kw)	SPEED DEVİR (RPM)	RATIO ORAN
50413511P0	PNEUMATIC PNÖMATİK	UNI	LEFT SIDE SOL YAN	21 Kgm 206 Nm	10,7 HP 8,1 Kw	375 RPM	1/1,25
50413521P0		ISO ADAPTER ADAPTÖRLÜ ISO					
50413531P0		FLANGE FLANŞLI					
50413541P0		SHAFT ŞAFTLI					
GEARBOX / ANA ŞANZİMANLAR				USED VEHICLES / KULLANILAN BAZI ARAÇLAR			
PTO EATON FS/FS0/H/V 4106-5206 A/B/H				180-617-620-622 BMC PRO / 200.26-180 FATİH BMC2520 FORD CARGO / AS 950 / CHRYSLER 180.12-210-220 CD-320 MIDLUM RENAULT /FODEN 2000 /ERF E6.18 / 1415-1718 FORD 8.163- 8.224-18-224 MAN/ FEDON ATKINSON E6.11 /			