

EATON 475 RIGHT SIDE UNI

EATON 475 SAĞ YAN UNI

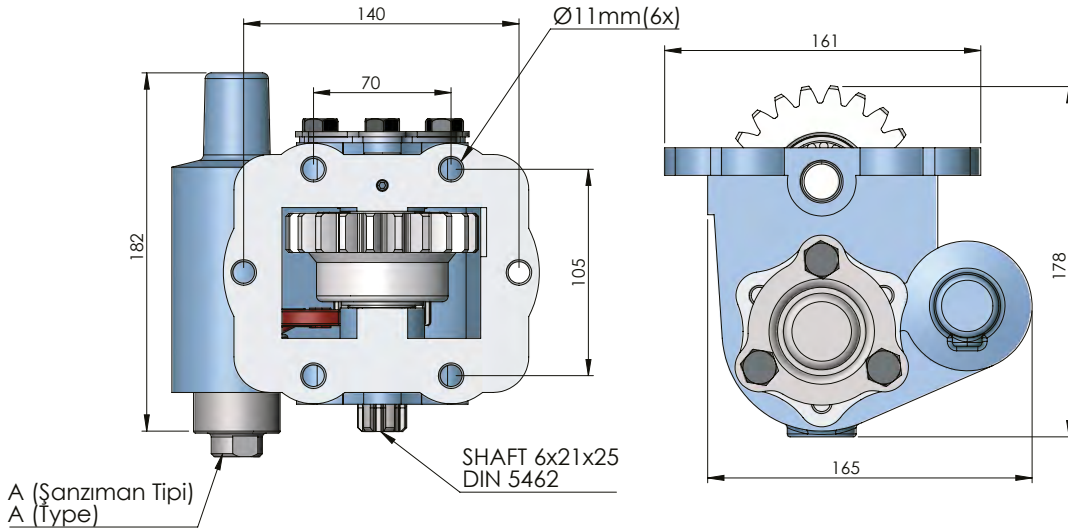
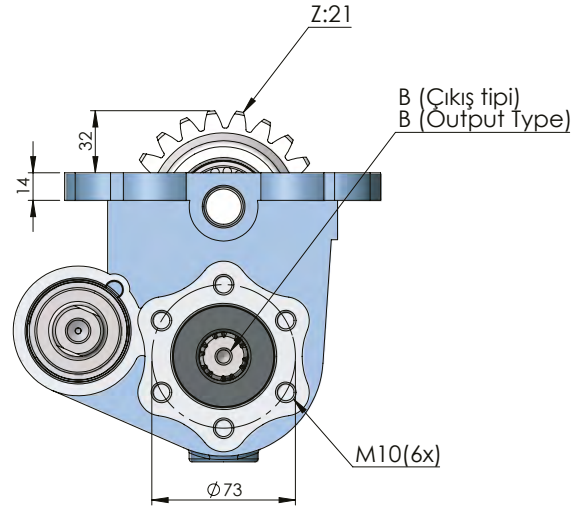

CODE KOD	TYPE TİP (A)	MOUNTING TYPE BAĞLANTI TIPI (B)	MOUNTING SIDE BAĞLANTI	TORQUE TORK (Kgm / Nm)	POWER GÜÇ (Hp / Kw)	SPEED DEVİR (RPM)	RATIO ORAN
50410512P0	PNEUMATIC PNÖMATİK	UNI	SIDE YAN	23 Kgm 225 Nm	15,8 HP 11,8 Kw	500 RPM	1/1,5
50410522P0		ISO ADAPTER ADAPTÖRLÜ ISO					
50410532P0		FLANGE FLANŞLI					
50410542P0		SHAFT ŞAFTLI					
GEARBOX / ANA ŞANZIMANLAR				USED VEHICLES / KULLANILAN BAZI ARAÇLAR			
PTO EATON-HEMA 475 R SML-SMA-SMO-SME-CMA-CMO				105.08-110.08-145.22 FATİH / 2014-2114-FORD CARGO 1800 INTER / 1212-1312 FORD (83-86) 1812-1814-2014-2117-2517 FORD (86) 140-1340 BMC / ZIL (RUS)			