

FOTON ATLAS 2

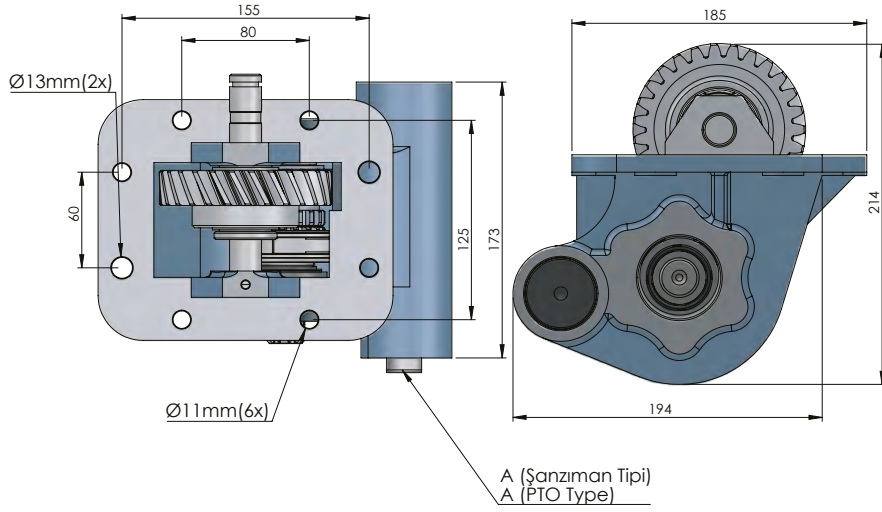
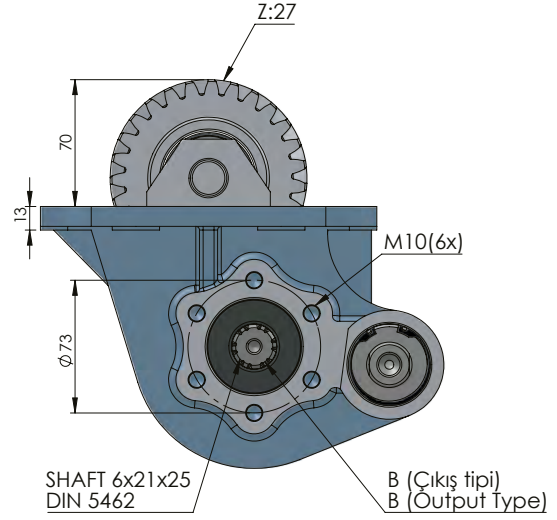

CODE KOD	TYPE TIP (A)	MOUNTING TYPE BAĞLANTI TİPİ (B)	MOUNTING SIDE BAĞLANTI	TORQUE TORK (Kgm / Nm)	POWER GÜÇ (Hp / Kw)	SPEED DEVİR (RPM)	RATIO ORAN
51911512P0	PNEUMATIC PNÖMATİK	UNI	SIDE YAN	23 Kgm 225 Nm	31,6 Hp 23,6 Kw	1000 RPM	1:1,12
51911522P0		ISO ADAPTER ADAPTÖRLÜ ISO					
51911532P0		FLANGE FLANŞLI					
51911542P0		SHAFT ŞAFTLI					
GEARBOX / ANA ŞANZIMANLAR				USED VEHICLES / KULLANILAN BAZI ARAÇLAR			
WLY6S51B-40B-00				L0171010184AQ 5,522 - 0,795-4,0L FOTON Otokar Atlas BAŞER			