

## FULLER 11609 UNI

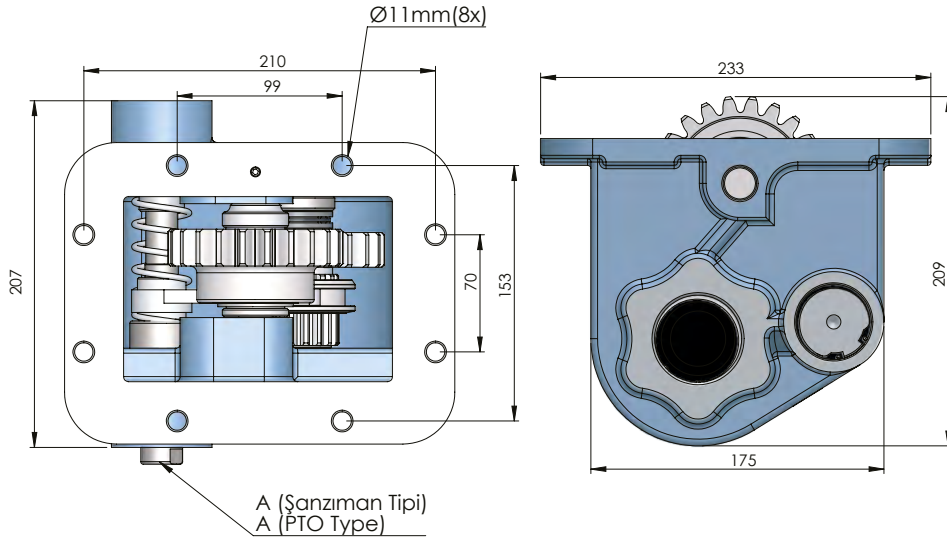
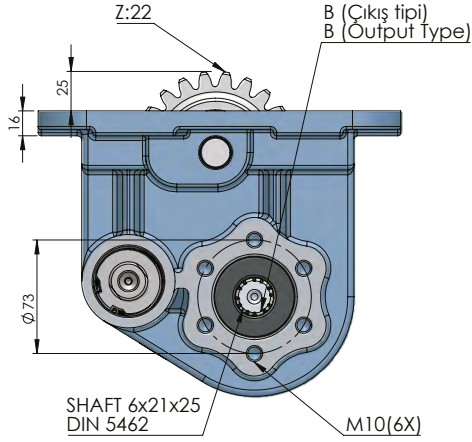

FULLER

POWER TAKE-OFFS  
P.T.O.

CODE KOD	TYPE TİP (A)	MOUNTING TYPE BAĞLANTI TİPİ (B)	MOUNTING SIDE BAĞLANTI	TORQUE TORK (Kgm / Nm)	POWER GÜÇ (Hp / Kw)	SPEED DEVİR (RPM)	RATIO ORAN
50520212P0	PNEUMATIC PNÖMATİK	UNI	BOTTOM ALT TAN	40 Kgm 392.4 Nm	57.8 Hp 43.1 Kw	1050 RPM	1:1
50520222P0		ISO ADAPTER ADAPTÖRLÜ ISO					
50520232P0		FLANGE FLANŞLI					
50520242P0		SHAFT ŞAFTLI					
GEARBOX / ANA ŞANZIMANLAR				USED VEHICLES / KULLANILAN BAZI ARAÇLAR			
RTO 11609-11613-11709-12709-14609 MRT0 / RTX 9509-9513-9710-11509-14613-15613-15615 A/B/H RT16108LL/FTS16108LL 16908LL(1050 RPM, SAĞ)				19.361-26.321-26.240-26.280 MAN/180.24-280.26-190.26-190.30-190.35-190.42-198.38-240.36-330.26-330.30-330.35-380E30 IVECO/270-26 FATİH BMC/DAF 85-2605-2800-2815-3030-3300-3330-3600-4400-ERF E6-E8-E12-EC 14 LEYLAND/FODEN 4000/MAGIRUS/ 19.320-30.280 MAN / FIAT 619-697			