

Features

- Suitable for direct in-line installation,
- Body material steel DIN 1.7225,
- Body surface nickel coated,
- Fluid viscosity 10 - 500 mm²/s (10-420 cSt),
- For mineral oil ISO 6743/4,

Özellikleri

- Direkt hat üzerine montaja uygun,
- Gövde malzemesi çelik DIN 1.7225,
- Gövde yüzeyi nikel kaplama,
- Akışkan viskozitesi 10 - 500 mm²/s (10-420 cSt),
- ISO 6743/4 Mineral yağlar için,



Order Code - Sipariş Kodu

GKV	-	06	-	B
Model - Tip		Size - Ebat		ThreadType Diş tipi
GKV		06 = 1/4"		B = BSPP
		08 = 3/8"		N = NPT
		10 = 1/2"		
		15 = 3/4"		
		20 = 1"		
		25 = 1 1/4"		
		30 = 1 1/2"		

Circuit - Şema

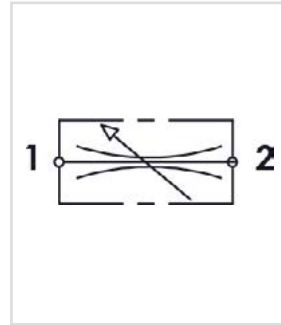

Sectional - Kesit

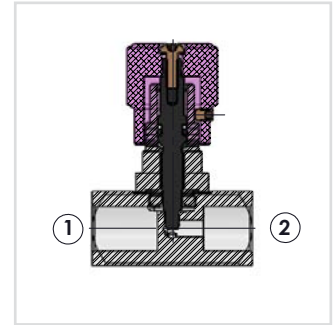

General Parameters and Dimensions (mm) – Genel parametreler ve ölçüler (mm)

Size - Ölçü	Q max	P max	ØD	A	B1	B2	B3	L	L1	L3	L4	Weight Ağırlık
	l/min	Bar	BSPP									Kg
GKV-06	15	400	1/4"	25	24,5	M20x1,5	30	54	75	7,5	13,5	0,34
GKV-08	30	400	3/8"	25	24,5	M20x1,5	30	54	75	7,5	13,5	0,32
GKV-10	50	300	1/2"	30	29,5	M25x1,5	30	64	80	9,5	13,5	0,50
GKV-15	80	300	3/4"	40	39,5	M35x1,5	41	81	109	15	23	1,16
GKV-20	150	300	1"	45	39,5	M35x1,5	41	102	114	15	23	1,55
GKV-25	200	250	1 1/4"	55	49	M45x1,5	51	102	136	12	23	2,41
GKV-30	300	200	1 1/2"	65	49	M45x1,5	51	102	146	12	23	3,06

