

**GM-MCG SERIE**

GEMMA HYDRAULIC OIL COOLER

**1. GENERAL INFORMATION**

**GM-MCG Serie** is our product line used in all industrial systems. The hydraulic cooling products we offer are manufactured with high quality standards. From material supply to production and post-production quality control processes, every stage is under strict control and surveillance.

**GM-MCG Serie is used in;**  
-Mobile systems,  
-Fixed unit applications,

Our products are complete cooling systems for AC-DC applications.

**HYDRAULIC OIL COOLER  
GM-MCG SERIE****PROPERTIES**

- Test Pressure: 30bar.
- Operating Pressure: 25 bar.
- Used for cooling Synthetic, Mineral Oils, and some liquids.
- Heat in the fluid is cooled through the help of a fan.
- Bar-Plate type cooling pad is used.
- Flexible 6063 aluminum material is used.
- Designed for all kinds of working conditions.
- Ready to use and easy to maintain.
- Has high efficiency and low cost.





## 2. TECHNICAL DATA

Dimensions	GM-MCG1	GM-MCG2	GM-MCG3	GM-MCG4	GM-MCG5	GM-MCG6	GM-MCG7	GM-MCG8
A	190	300	400	400	550	650	790	800
B	170	305	395	395	410	560	560	650
C	45	63	63	94	94 (63)	94	94	140
D	220	360	452	452	467	612	613	723
E	280	415	515	535	690	790	940	960
F	45	45	45	63	63	63	70	70
G	-	-	-	-	-	-	-	-
H	225	265	265	330	380	480	245	375
I	125	125	125	125	125	125	155	165
K	155	155	155	155	155	155	200	200
L	-	-	-	-	-	-	-	-
M	-	-	-	-	-	-	-	-
N (max)	12-24-172 230-400-217	12-24-172 230-400-217	12-24-187 230-400-232	12-24-187 230-400-237	187 242	187 257	187 237	197 297
O	1/2" BSP	1/2" BSP	1" BSP	1" BSP	1" BSP	1" BSP	1 1/2" BSP	1 1/2" BSP
Max. Flowrate (Lt./min)	40	80	100	120	140	160	180	220
Capacity (Kcal/h)	2000	5500	6000	12000	20000	25000	40000	60000
Fan Diameter	155-155-160	195-195-200	195-195-200	245-245-250	290-290-300	345-345-350	10" x 2-10" x 2-630	14" x 2-14" x 2-630
Fan Speed	750-750-700	2700-2700-2800	2700-2700-2800	2700-2700-2800	2700-2700-2800	2700-2700-2800	2700-2700-1500	2700-2700-1500
dB(A) 1m	51-51-50	72-72-68	72-72-68	74-74-72	74-74-72	78-78-74	74-74-89	74-74-98
Voltage[V]	12-24-230-400	12-24-230-400	12-24-230-400	12-24-230-400	12-24-230-400	12-24-230-400	12-24-230-400	12-24-230-400
kW	0.04-0.04-0.05	0.09-0.10-0.06	0.09-0.10-0.06	0.11-0.11-0.10	0.18-0.18-0.19	0.21-0.21-0.32	0.15-0.15-0.43	0.15-0.15-0.43
Operating Pressure (Bar)	25	25	25	25	25	25	25	25

## 3. DIMENSIONS OF THE COOLERS BETWEEN GM-MCG1 AND GM-MCG6

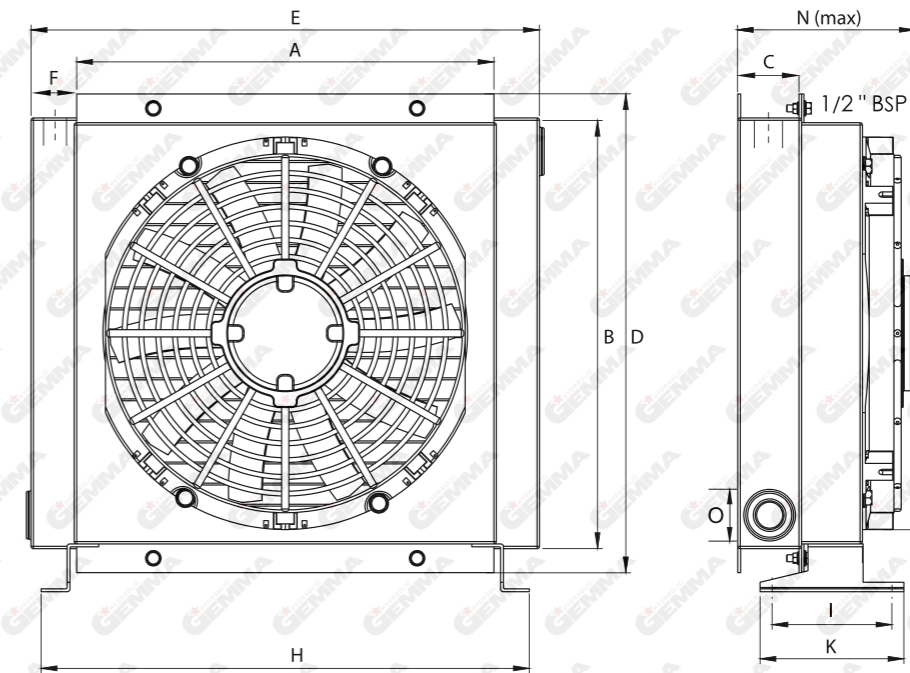

## 4. DIMENSIONS OF THE COOLERS BETWEEN GM-MCG7 AND GM-MCG8

