

## GM-MCM SERIE

GEMMA HYDRAULIC OIL COOLER

### 1. AC-DC MOTOR OIL COOLERS

**GM-MCM Serie** is our product line used in all industrial systems. The hydraulic cooling products we offer are manufactured with high quality standards. From material supply to production and post-production quality control processes, every stage is under strict control and surveillance.

**GM-MCM Serie** is used in;  
-Mobile systems,  
-Fixed unit applications,

Our products are complete cooling systems for AC-DC applications.



## HYDRAULIC OIL COOLER GM-MCM SERIE

### PROPERTIES

- Test Pressure: 30bar.
- Operating Pressure: 25 bar.
- Used for cooling Synthetic, Mineral Oils, and some liquids.
- Heat in the fluid is cooled through the help of a fan.
- Bar-Plate type cooling pad is used.
- Flexible 6063 aluminum material is used.
- Designed for all kinds of working conditions.
- Ready to use and easy to maintain.
- Has high efficiency and low cost.



2. TECHNICAL DATA

Dimensions	GM-MCH1	GM-MCH2	GM-MCH3	GM-MCH4	GM-MCH5	GM-MCH6	GM-MCH7	GM-MCH8	GM-MCH9	GM-MCH10	GM-MCH11
A	200	300	400	400	550	650	790	800	1025	1025	1170
B	195	305	395	395	410	560	560	650	010	910	1200
C	63	63	63	94	94 (63)	94	94	140	94	113	140
D	254	360	452	452	467	612	613	723	992	992	1270
E	315	415	515	535	690	790	940	960	1350	1350	1520
F	45	45	45	63	63	63	70	70	75	75	70
G	65	115	160	160	165	235	235	280	390	390	532
H	80	150	200	200	200	310	310	400	440	440	525
I	140	190	190	240	240	240	240	240	215	215	200
K	200	250	250	300	300	300	300	300	580	580	750
L	-	-	-	-	-	-	-	-	-	-	-
M	-	-	-	-	-	-	-	-	-	-	-
N (max)	175	370	400	430	440	450	450	590 app	650 app	790 app	900 app
O	1" BSP	1" BSP	1" BSP	1" BSP	1" BSP (1" BSP)	1" BSP	1" BSP	1" BSP	-	-	-
Max. Flowrate (Lt./min)	20	50	75	75	100	120	150	200	250	300	400
Capacity (Kcal/h)	1000	2500	5000	5000	6000	12000	22500	50000	55000	60000	70000
Fan Diameter	165-165-175	250-250-250	350-350-350	350-350-350	8 x2-8 x2-200x2	10 x2-10 x2-250x2	14 x2-14 x2-500	630	900	900	1000
Fan Speed	1500-1500-2800	1500-1500-2800	1500-1500-2800	1500-1500-2800	1500-1500-2800	1500-1500-2800	1500-1500-1300	1500	1000	1000	1000
dB(A) 1m	79-79-85	75-74-80	76-75-79	76-75-79	78-79-76	75-74-80	80-80-72	90	89	88	90
Voltage(V)	12-24-230-400	12-24-230-400	12-24-230-400	12-24-230-400	12-24-230-400	12-24-230-400	12-24-230-400	230-400	230-400	230-400	230-400
kW	0.08-0.08-0.05	0.15-0.15-0.25	0.20-0.25-0.35	0.20-0.25-0.35	0.10-0.10-0.09	0.15-0.15-0.25	0.25-0.35-0.37	2.2	2.2	3.0	7.5
Operating Pressure (Bar)	25	25	25	25	25	25	25	25	15	15	15

3. DIMENSIONS OF THE COOLERS BETWEEN GM-MCM1 AND GM-MCM7

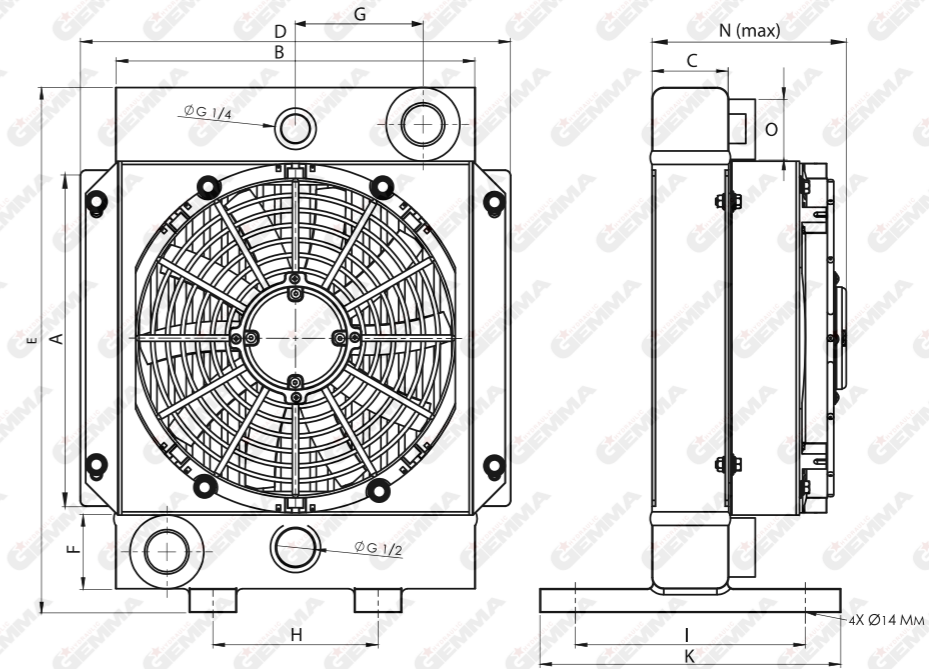

4. DIMENSIONS OF THE COOLERS BETWEEN GM-MCM8 AND GM-MCM11

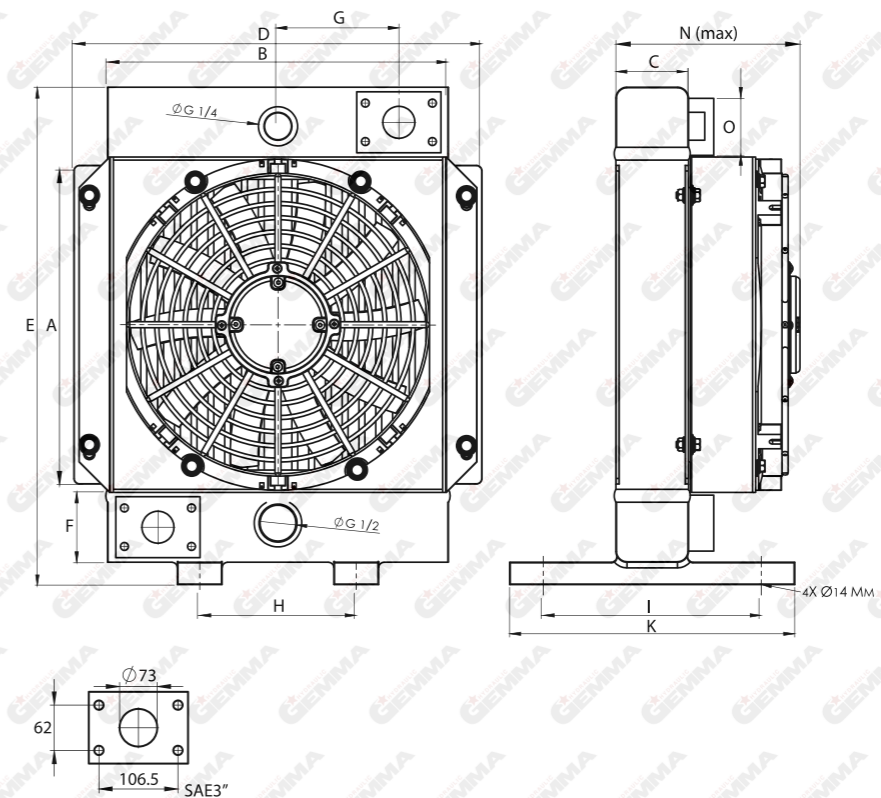

GM-MCM SERIES  
GEMMA HYDRAULIC OIL COOLER

OIL COOLERS  
YAĞ SOĞUTUCULAR

GM-MCM SERIES  
GEMMA HYDRAULIC OIL COOLER

OIL COOLERS  
YAĞ SOĞUTUCULAR