

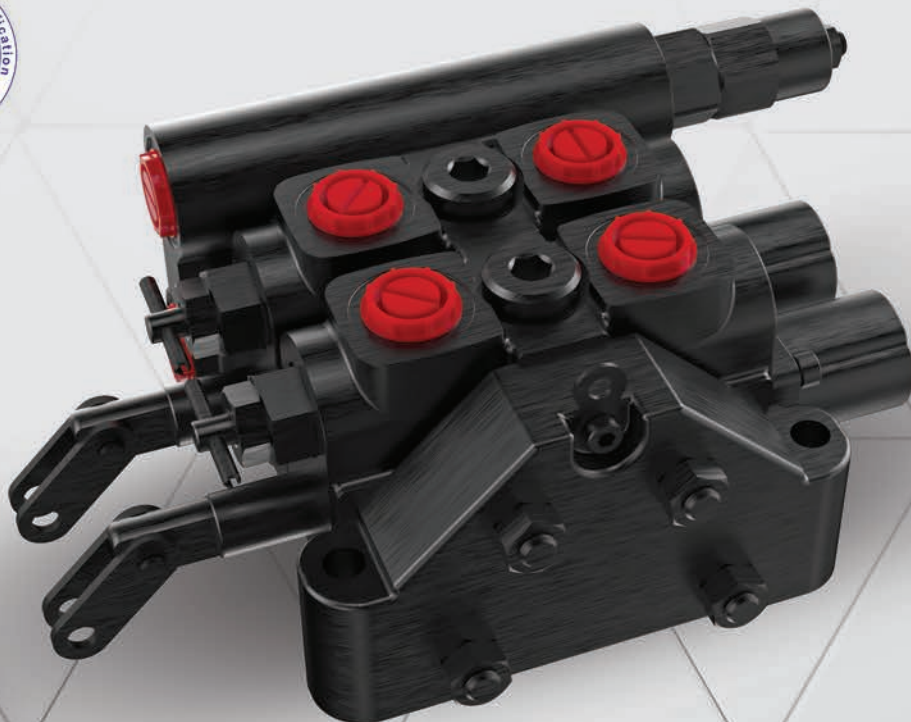

SPECIAL TRACTOR  
VALVES

**GMM-DMF**

CE



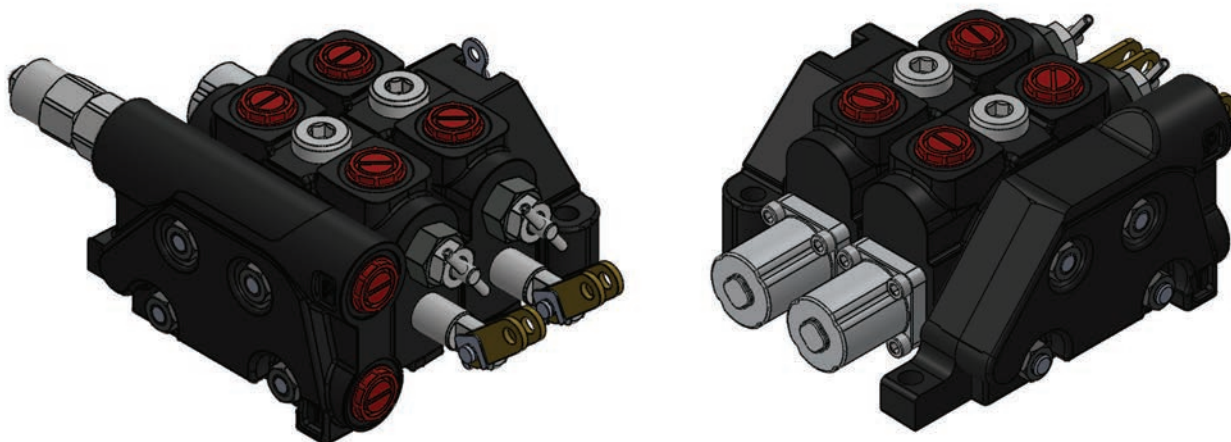

## CONTENTS

Working Conditions	383
Dimensional Data	384
Hydraulic Circuit	385
Performance Data And Curve	387
Inlet Relief Options	388
Ordering Codes	390
Spool Options	392
Spool Positioners – Side of Return	394
Installation and Maintenance	396
Technical Data	397

### Additional Informations

**Note:** This catalog shows the product in the most standard configurations. For Other Configurations, more detailed information or special request, Please contact Customer Service Dept.

**Warning!:** All specifications of this catalog refer to the standard product at this date (09/2018). GEMMA, oriented to a continuous improvement, reserves the right to discontinue, modify or revise the specifications, without notice.

GEMMA IS NOT RESPONSIBLE FOR ANY DAMAGE CAUSED BY AN INCORRECT USE OF THE PRODUCT.

**WORKING CONDITIONS**

Nominal Flow Rating / Displacement	80 l/min	21 U.S.G.P.M
Maximum Working Pressure (Series Circuit)	210 Bar	3050 PSI
Maximum Working Pressure (Parallel Circuit)	315 Bar	4600 PSI
Max. Back Pressure	25 Bar	360 PSI
Oil Temperature with NBR Seals	-20 to 80 C°	-4 to 176 F °
with FPM (Viton) Seals	-20 to 100 C°	-4 to 212 F °
Oil Viscosity – Operating Range	From 10 to 75 mm <sup>2</sup> /s	From 10 to 75 cSt
Minimum / Maximum	10 / 400 mm <sup>2</sup> /s	10 / 400 cSt
Oil Filtration	≤30 μ	
Ambiant Temperature Range	-35 to 60 C°	-31 to 140 F °
Number Of Spools	1 to 12	
Internal Leakage (at 100 bar (1450 PSI), 40C° (110 F°), 46 cSt – A(B)–T)	3 cm <sup>3</sup> /min	0,18 in <sup>3</sup> /min
Max. Level Of Contamination	19/16 - ISO 4406	
Tie rod tightening torque	30 Nm	22 lbft

**Not:** This catalogue shows technical specifications measured with mineral oil of 46 mm<sup>2</sup>/s–46 cSt viscosity at 40 C° temparture.

**Features**

- Simple, compact and heavy duty designed sectional valves from 1 to 4 sections for open and closed center hydraulic systems.
- Fitted with a main pressure relief valve.
- Interchangeable spool diameter is 18 mm – 0,71 in.
- Available manual, pneumatic, hydraulic and electro-pneumatic spool control kits.

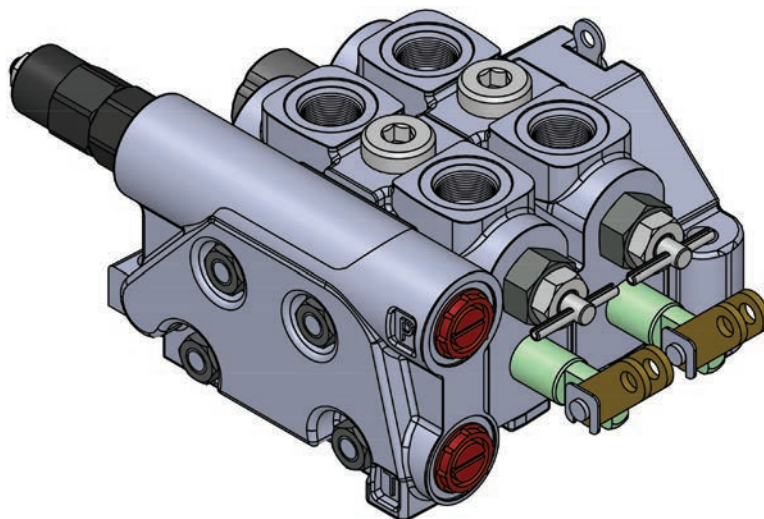

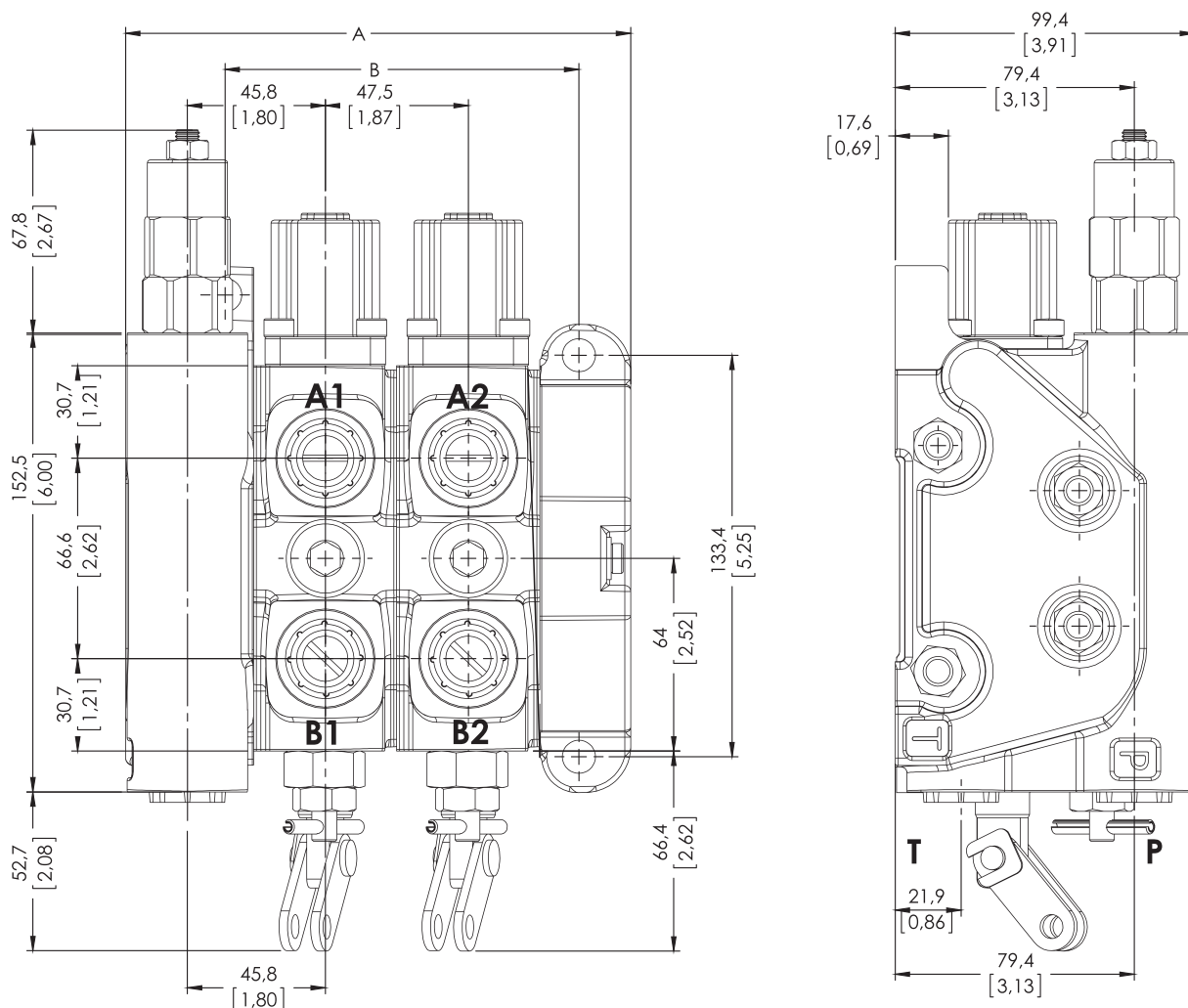
**DIMENSIONAL DATA**

TYPE	A		B		Weight	
	mm	in	mm	in	Kg	lb
GMM- DMF-1P	119,2	4,69	69	2,71	7.58	16.71
GMM- DMF-2P	166,7	6,56	116,5	4,58	10.96	24.16
GMM- DMF-3P	214,2	8,43	164	6,45	14.34	31.61
GMM- DMF-4P	261,7	10,30	211,5	8,32	17.37	39.06

**STANDARD THREADS**

PORT	BSP (Iso 228) 1/2" Series	UN-UNF (Iso 11926-1)	Metric (Iso 262)
P Inlet	G 1/2	3/4 - 16 UNF	M22x1.5
A-B Ports	G 1/2	3/4 - 16 UNF	M22x1.5
T Outlet	G 1/2	3/4 - 16 UNF	M22x1.5

**HYDRAULIC CIRCUIT**

**Parallel**

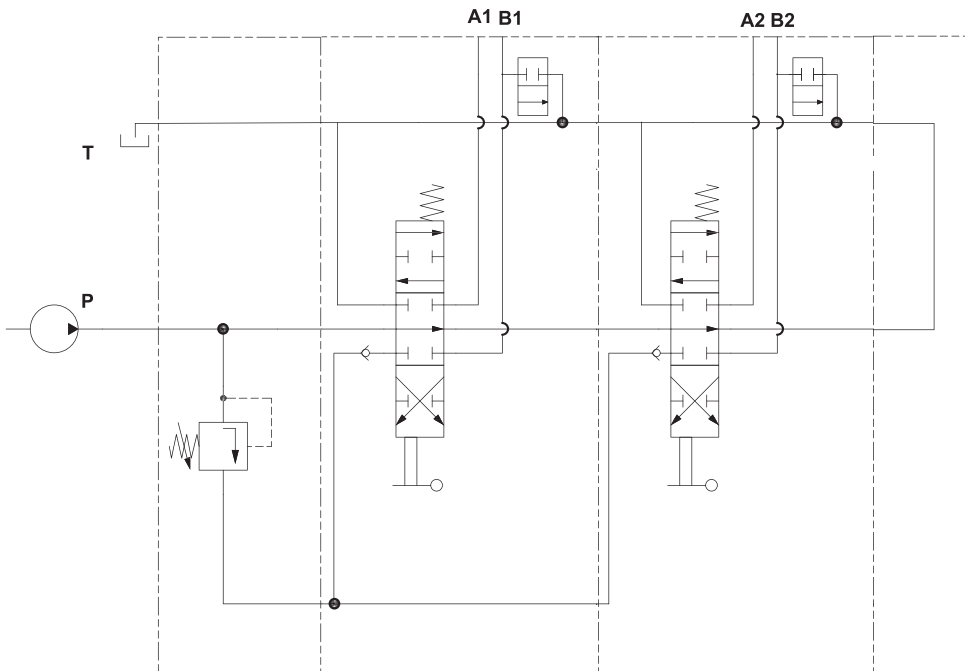
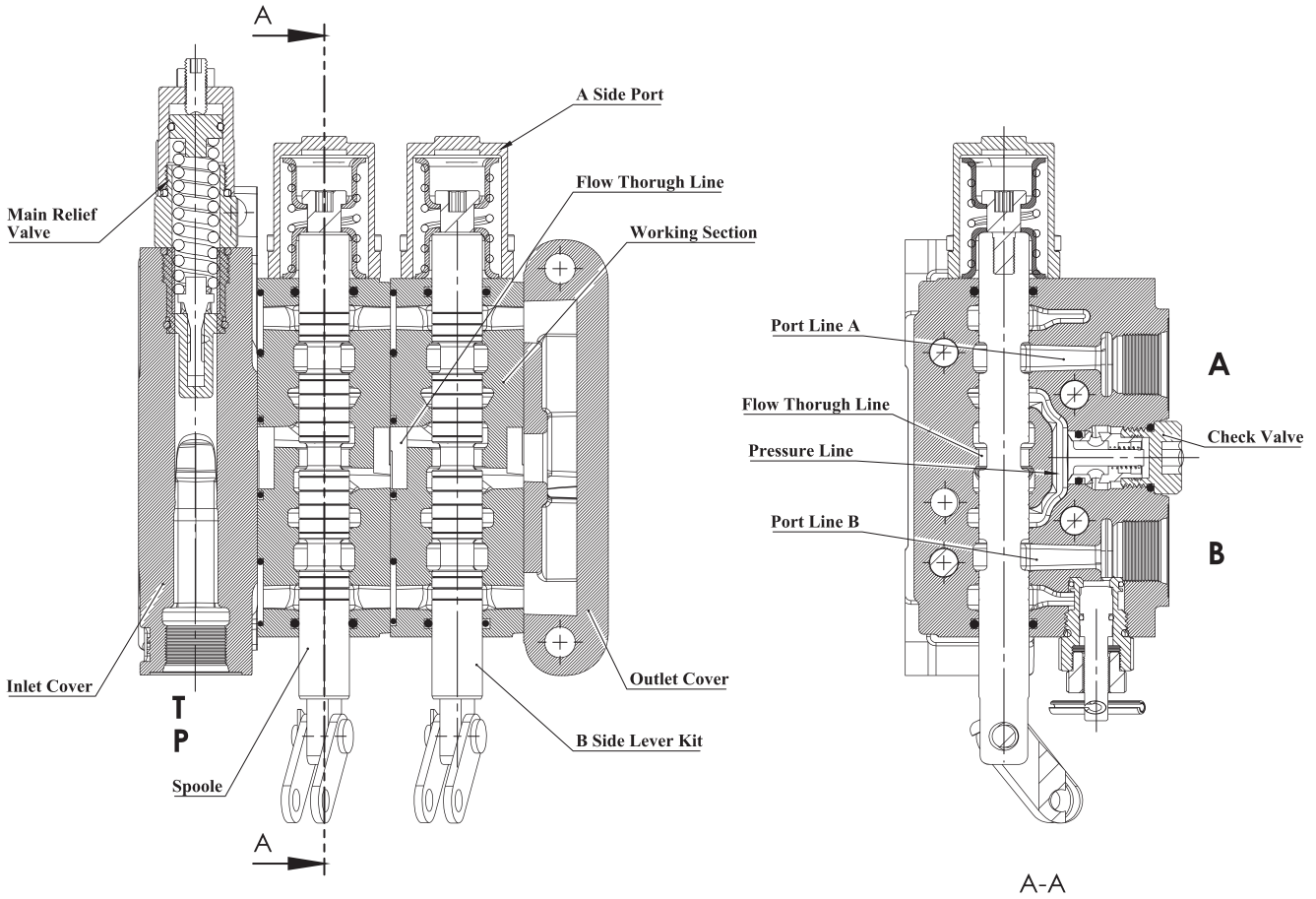

**Code: GMM DMF-2P (SD(-SMR2-125)/P-1A -SR/ P-1A -SR**

HYDRAULIC CIRCUIT

Inlet Cover – Pump Side

SD – Side inlet with direct pressure relief valve  
 SP – Side inlet with Non - relief valve

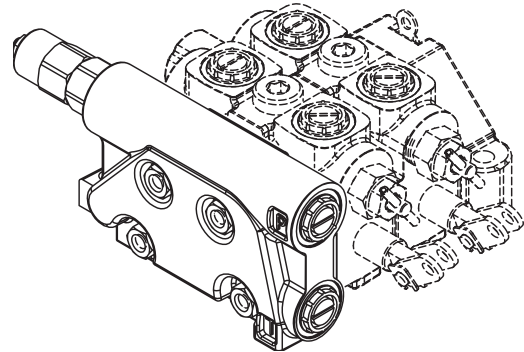

Type = SD

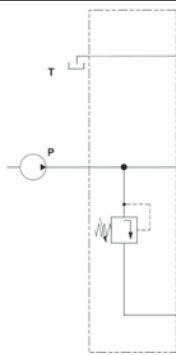

Type = SP

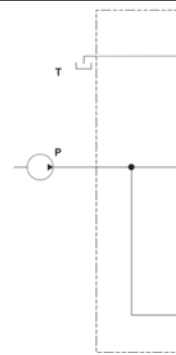

Working Sections

P – Parallel

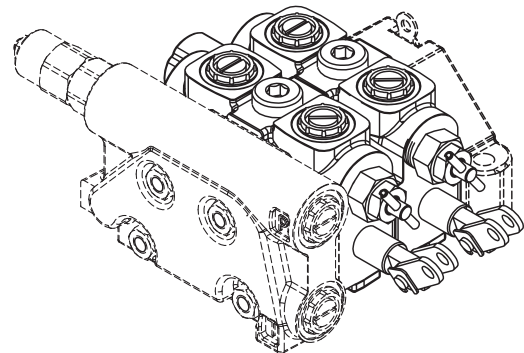

Type=P

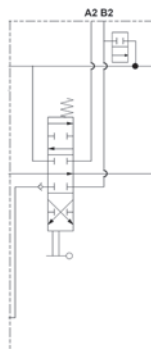

PERFORMANCE DATA AND CURVE

Open Center - Pressure Drop (P-T)

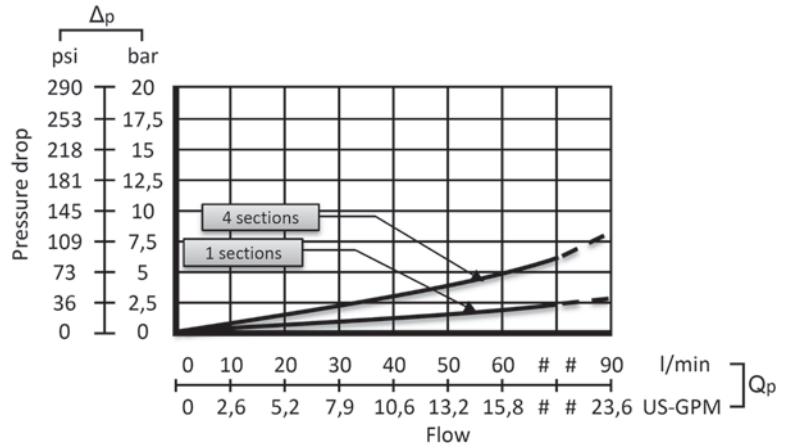
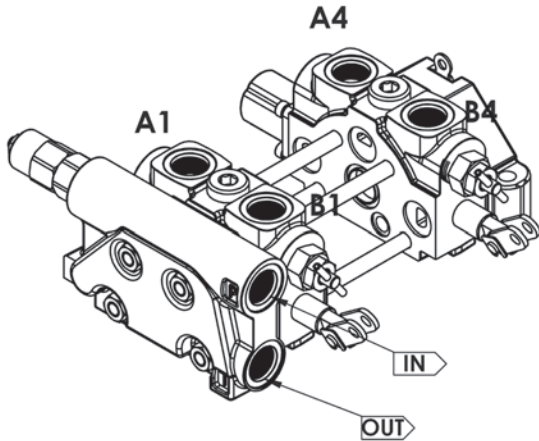

Inlet to Work Port - Pressure Drop (P-A/B)

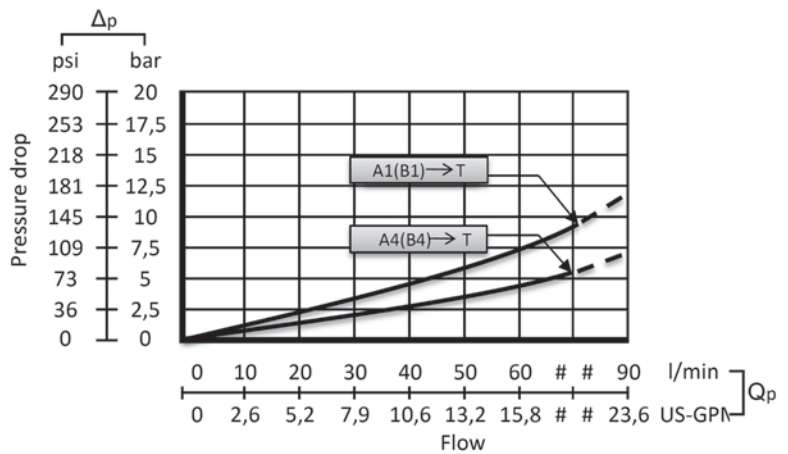
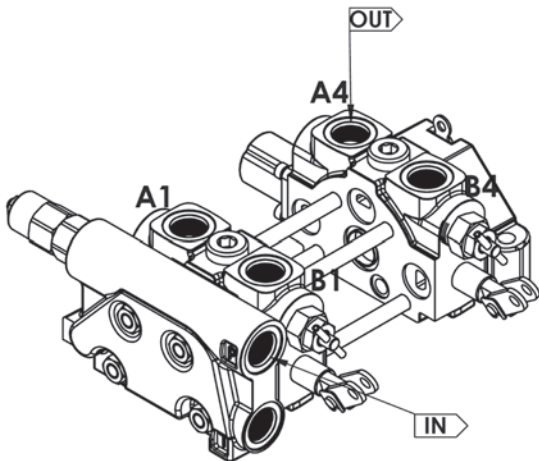

Work Port to Outlet - Pressure Drop (A/B-T)

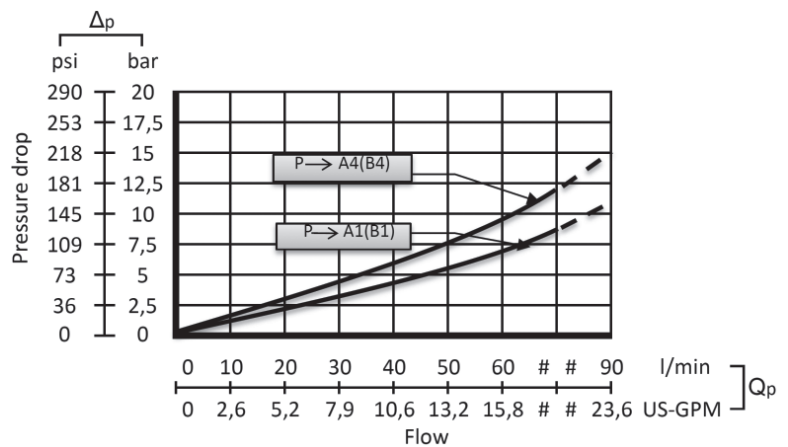
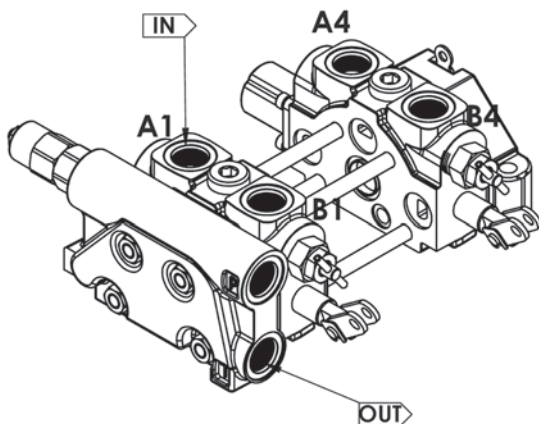

INLET RELIEF OPTIONS

Direct Pressure Relief Valve

Code:

SMR2 – 125

- Pressure Setting Bar in (Standard 125 bar)
- Standard Main Relief Spring Type -2

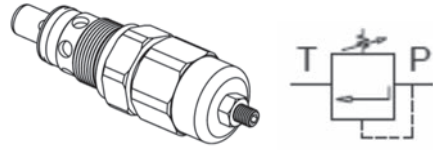

Performance Data

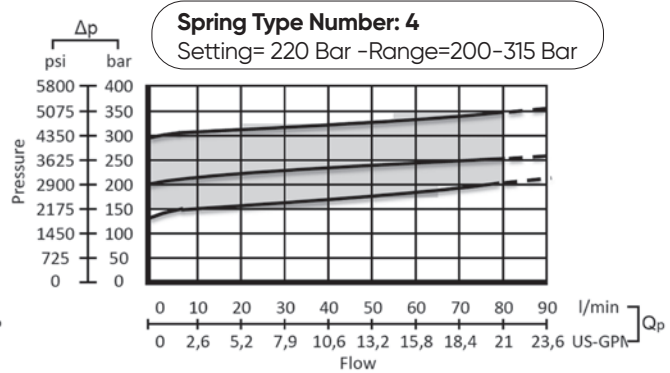
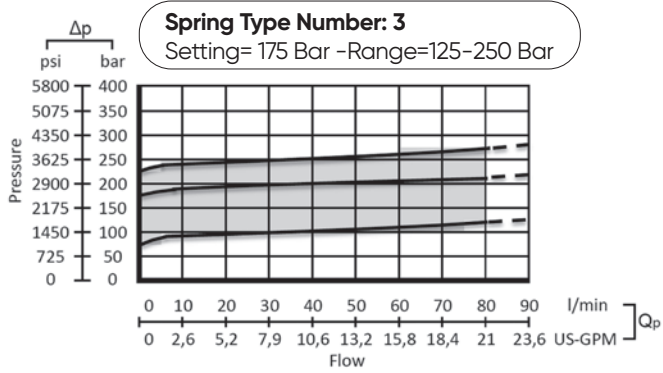
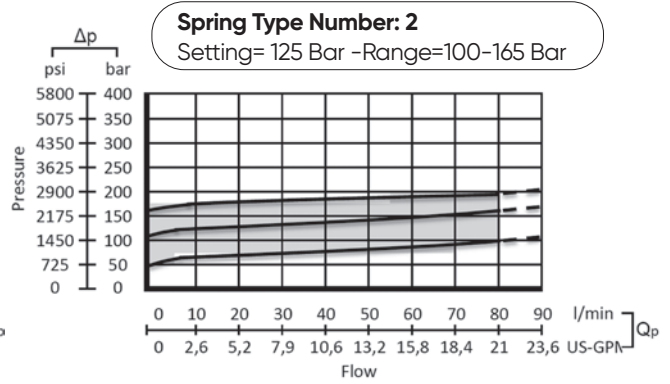
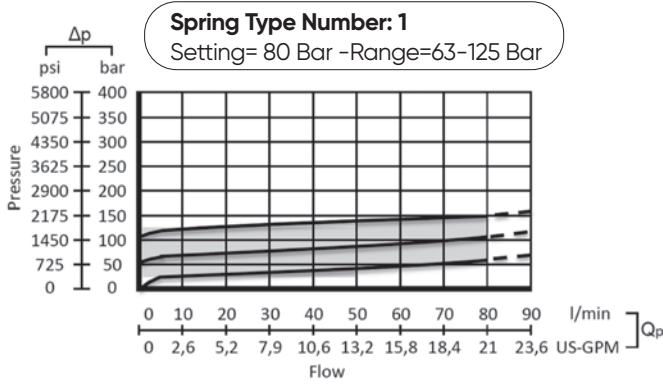

Adjustment Type on Valve

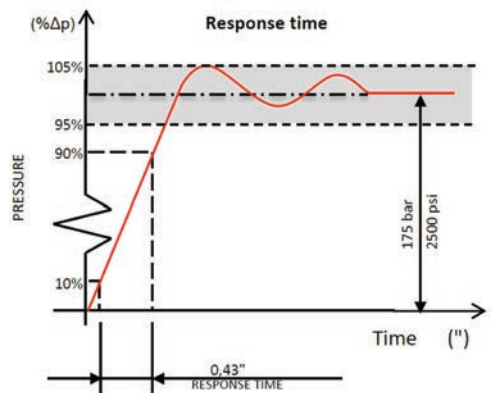
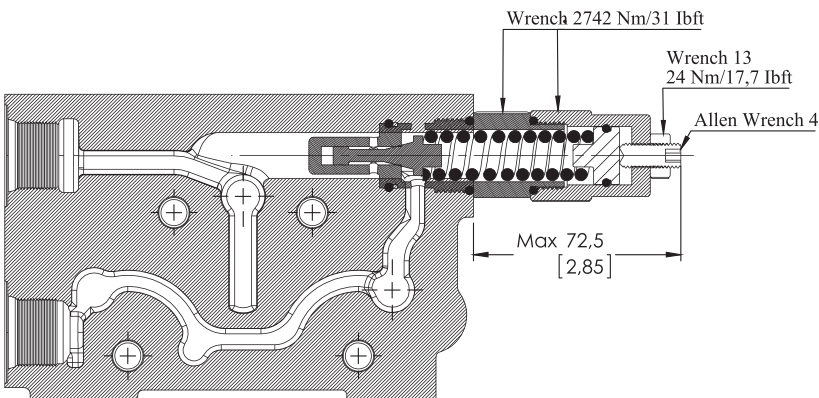



**INLET RELIEF OPTIONS**

**Non Relief Blanking - SP**

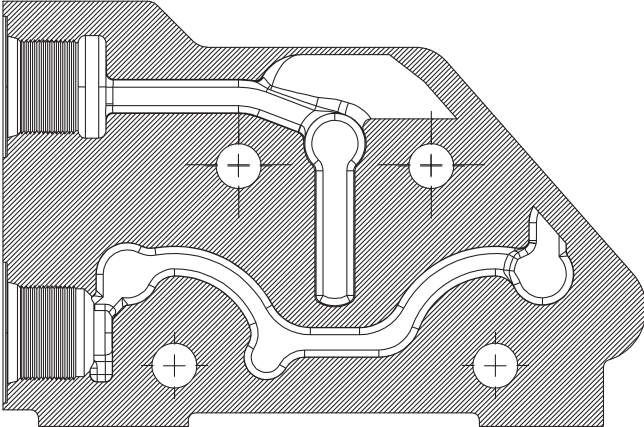

ORDERING CODES

Order Example

GMM DMF - 2P (SD - SMR2 - 125) / P - 1A - SR / P - 1A - 80P

Base Code  
"0"

1

1.2

2.1

2.2

2.3

1st Section

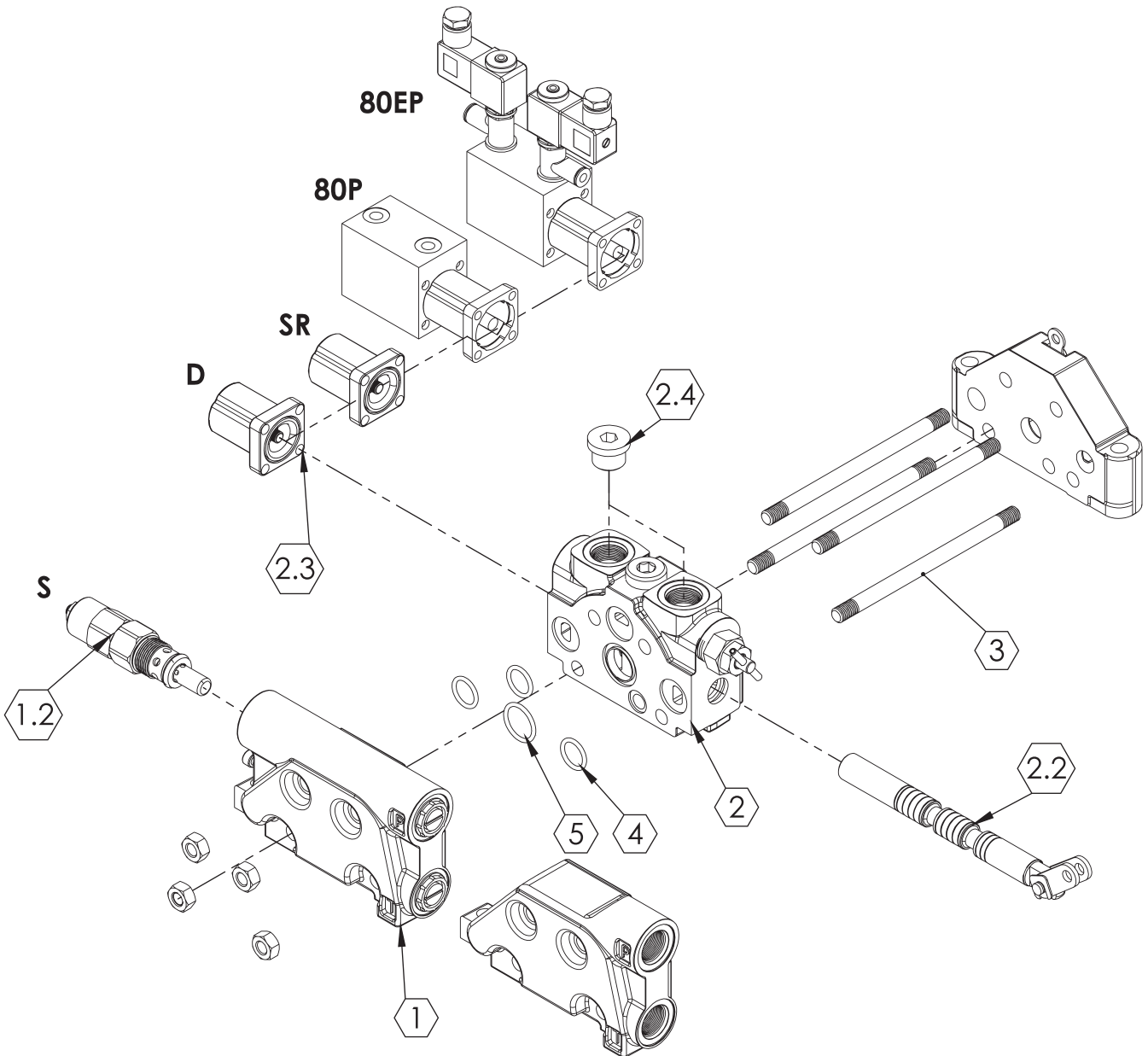

**ORDERING CODES**

**1- Inlet Section**

**GMM DMF-2P** DMF = Valve Type-(DMF)- Sectional  
 (80) - Max. Flow Rate  
 2P = Sections Quantity  
**SD** = Side inlet with direct pressure relief valve  
 (1DD80100)  
**SP** = Non relief valve (1DP80100)

**2- Working Section**

**P** = Parallel (2D80100)

**3- Assembling Kit**

Tie rod kit for 1 section valve - (4TRK180100)  
 Tie rod kit for 2 section valve - (4TRK280100)  
 Tie rod kit for 3 section valve - (4TRK380100)  
 Tie rod kit for 4 section valve - (4TRK480100)

**4-5-O\_Ring Kit**

**5.** -17.00x2.65 NBR 70 SH O-Ring seal (3 Qty.)  
 (5MK80100)  
**6.** -22.40x2.65 NBR 70 SH O-Ring seal (1 Qty.)  
 (6MK80100)

**1.\*-Inlet Options**

**1.1 Inlet Cover**  
**Body** = Standard (11DP80100)  
 Non Relief Valve (11DS80100)  
**1.2 Inlet Relief**  
**SMR1-080** - (12SMR180080)-Range 63-125 bar  
 Setting 80 bar  
**SMR2-125** - (12SMR280125)- Range 100-160 bar  
 Setting 125 bar  
**SMR3-175** - (12SMR380175)- Range 125-250 bar  
 Setting 175 bar  
**SMR4-220** - (12SMR480220)-Range 200-315 bar  
 Setting 220 bar

**2.\*- Working Options**

**2.1 Working Section**  
 PA= Without ports valve prearrangement, with parallel circuit - Body (21DSPA80100)  
**2.2 Spool Options**  
 1A -(22DS80110) - 3 Positions, Double acting  
 2A -(22DS80120) - 3 Positions, Double acting  
 A to tank B Blocked  
 3A -(22DS80130) - 3 Positions, Double acting  
 B to tank A blocked  
 4A -(22DS80140) - 3 Positions, Double acting  
 A and B tank  
 5A -(22DS80150) - 3 Positions, Single acting on A (A to tank)  
 6A -(22DS80160) - 3 Positions, Single acting on B (B to tank)  
**2.3 Spool Positioners**  
**SR** = Spring Return in neutral position - (26SR80100)  
**D** = Detent in position 1, neutral and 2 -(26D80100)  
**80P** = ON/OFF Pneumatic - (2645P150100)  
**80EP** = 12 VDC ON/OFF electro-pneumatic  
 (2680EP150112)  
 24 VDC ON/OFF electro-pneumatic -  
 (2680EP150124)

SPOOL OPTIONS

Spool Type - 1A

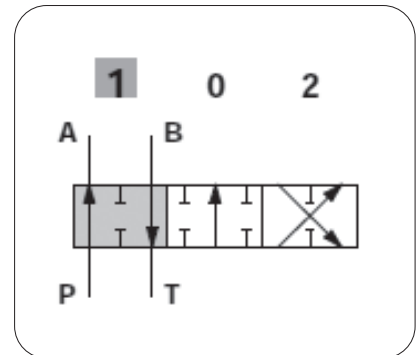
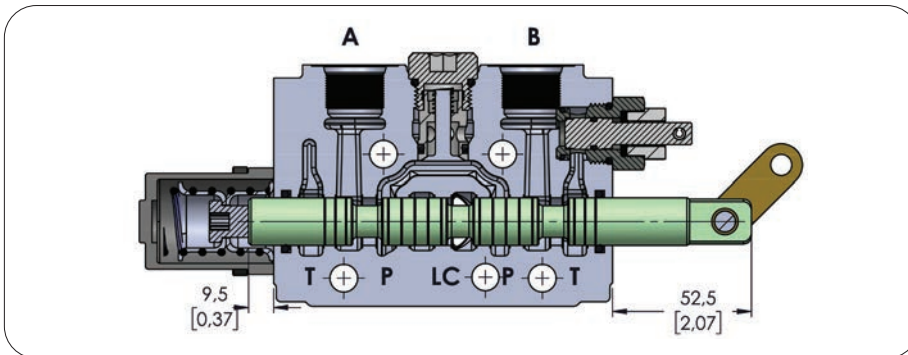
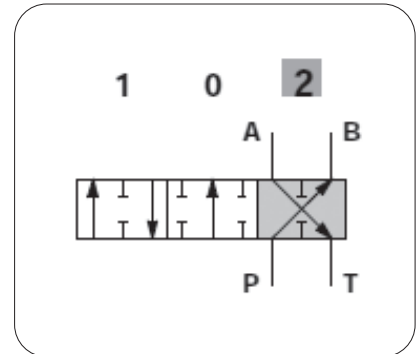
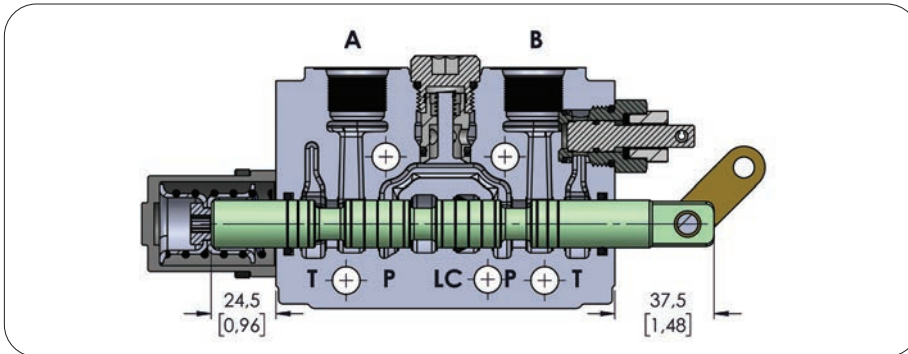
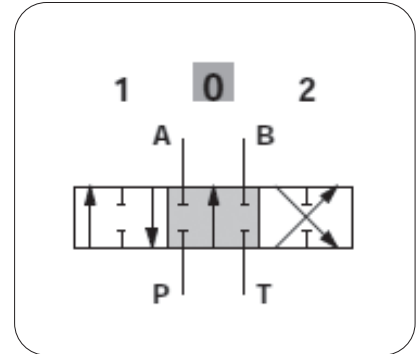
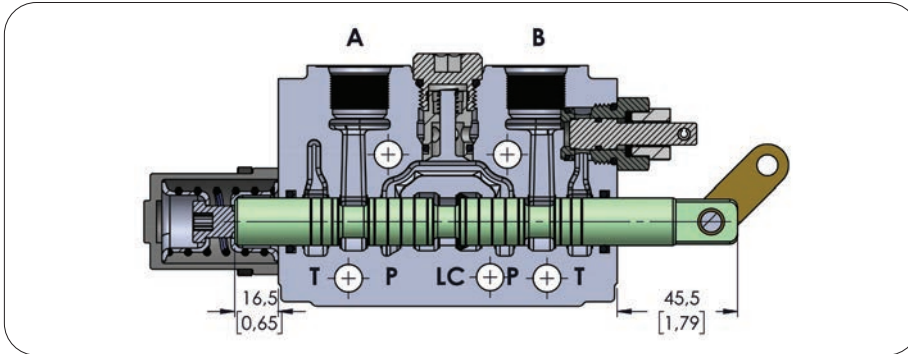

Performance Curve And Data

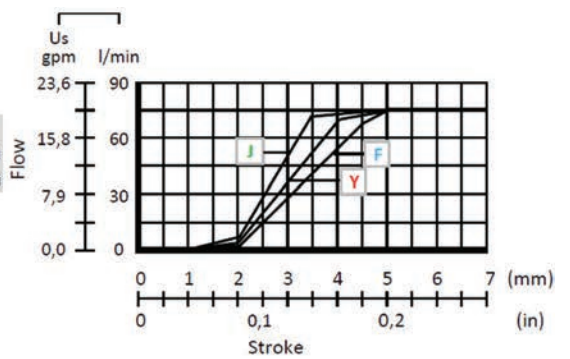
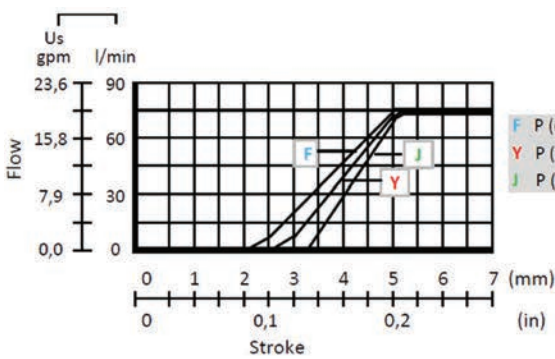

SPOOL OPTIONS

Spool Type - 2A

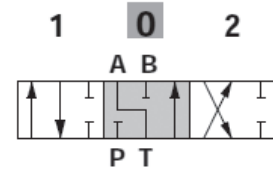
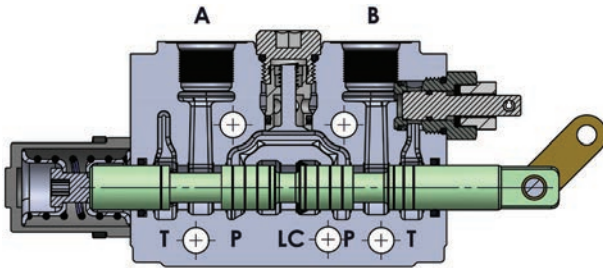

Spool Type - 3A

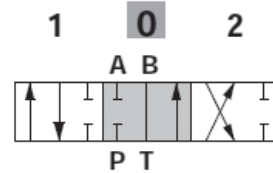
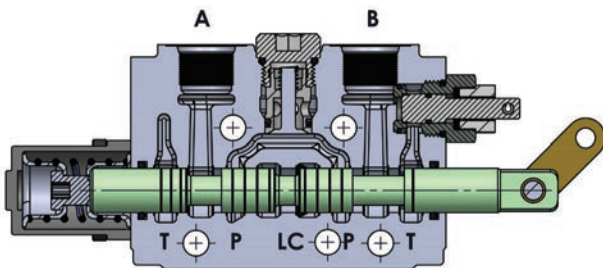

Spool Type - 4A

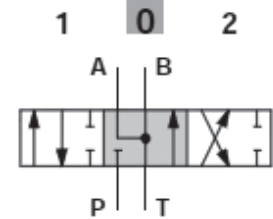
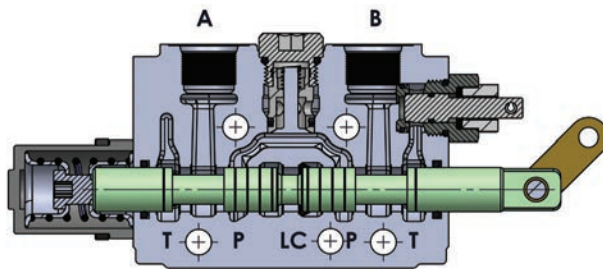

Spool Type - 5A

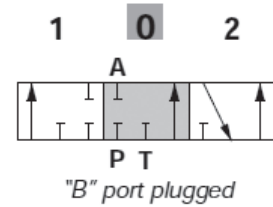
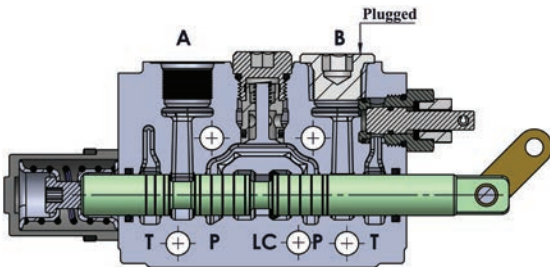

Spool Type - 6A

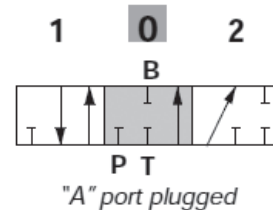
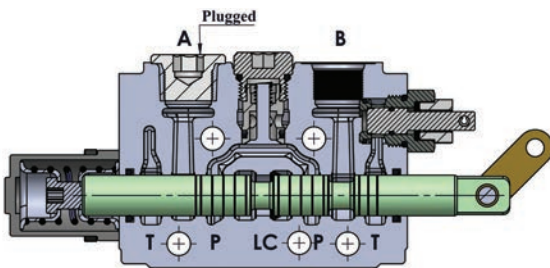

**SPOOL POSITIONERS – SIDE OF RETURN**

**With Spring Return in Neutral Position**

Kit No: **SR**

Sectional Appearance

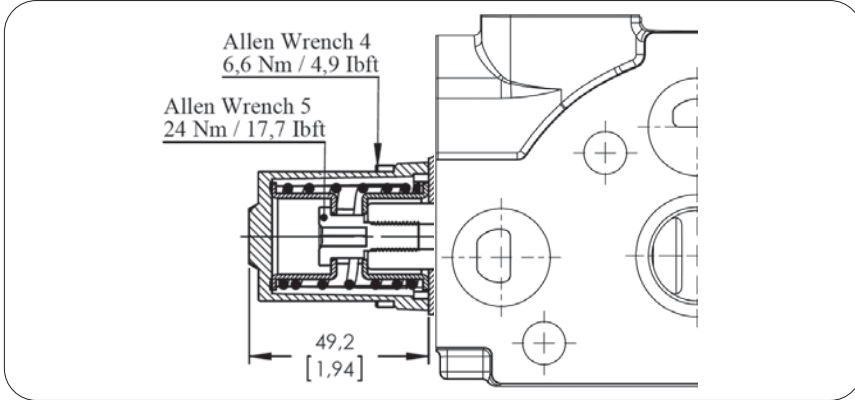

Diagram

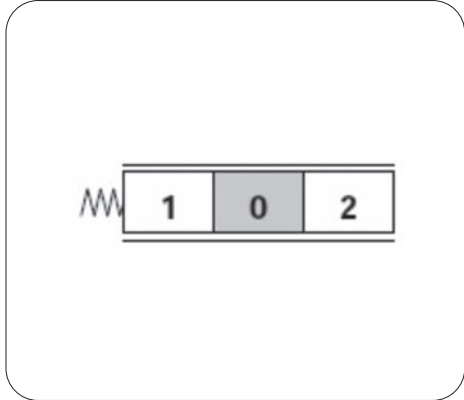

**With Detent**

Kit No: **D**

Sectional Appearance

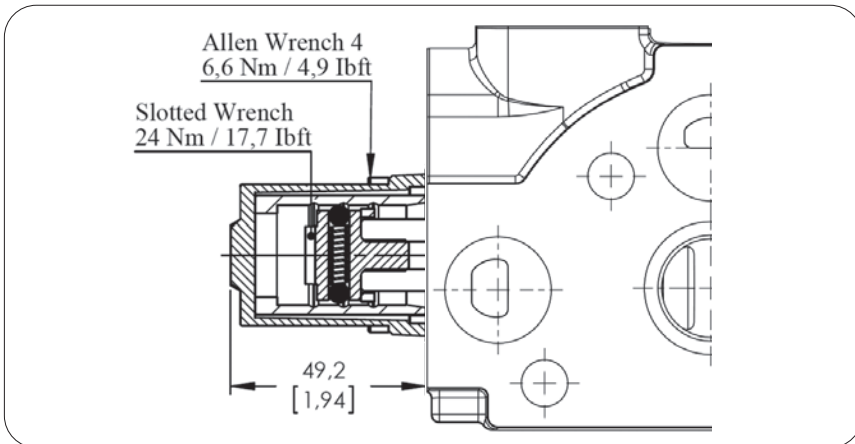

Diagram

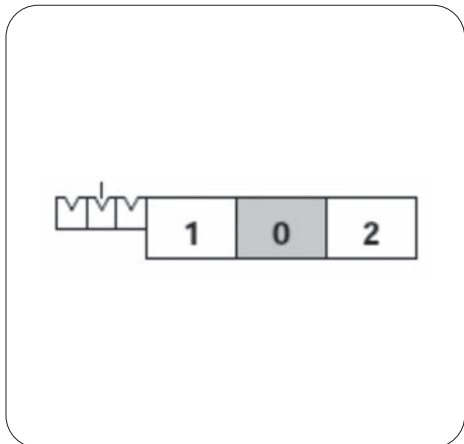

**Force - stroke diagram**

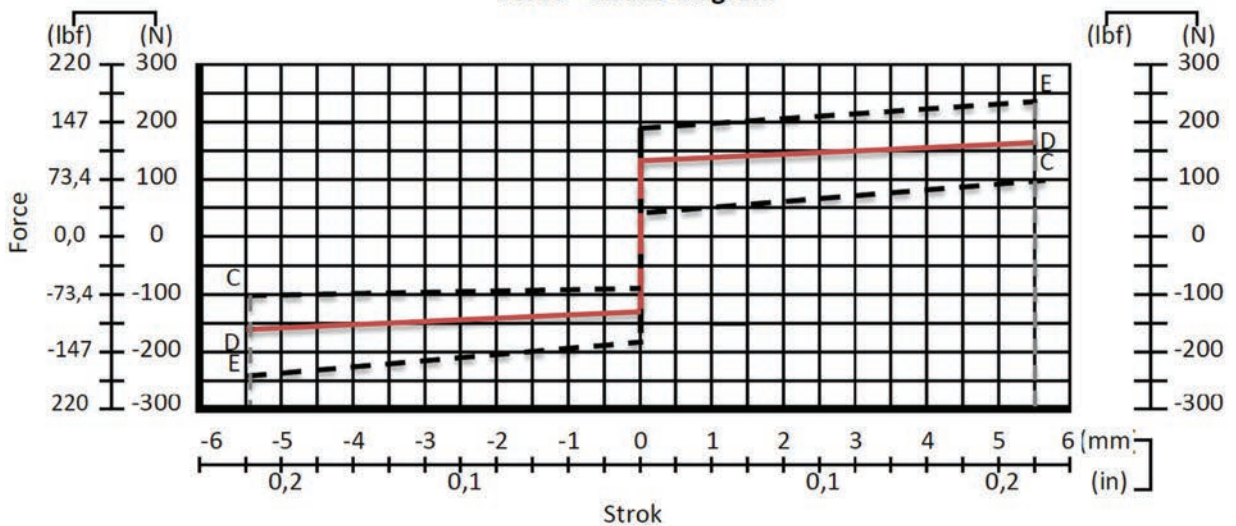

**SPOOL POSITIONERS – SIDE OF RETURN**

**ON/OFF Pneumatic Control**

Kit No: **80P**

Sectional Appearance

Diagram

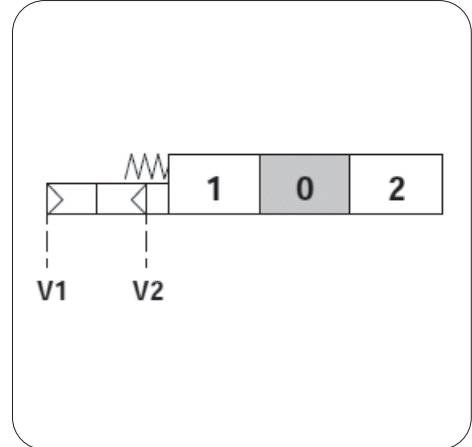
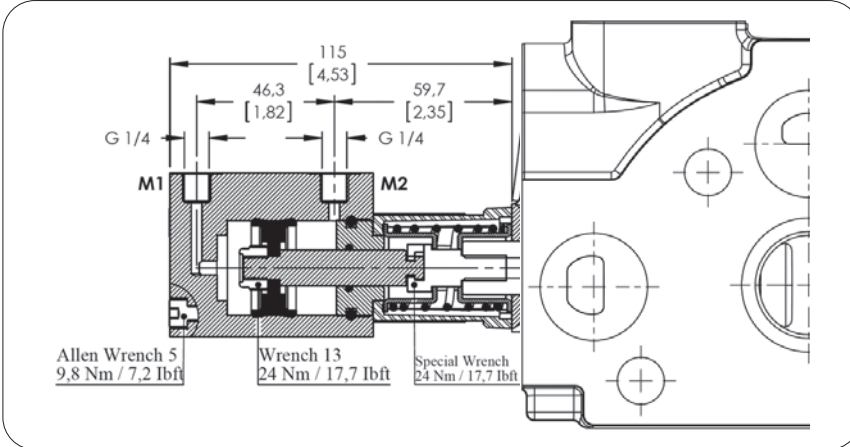

**Operating Features**

Pilot Pressure .....: 6 Bar (Max. 10) / 87 Psi (Max. 145)

**ON/OFF Electro-Pneumatic Control**

Kit No: **80EP**

Sectional Appearance

Diagram

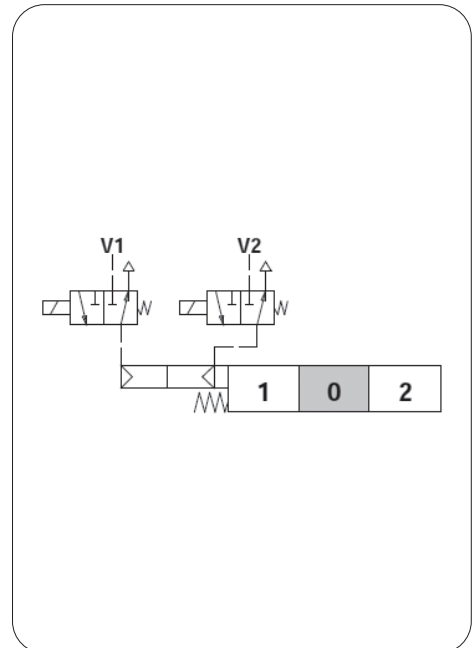
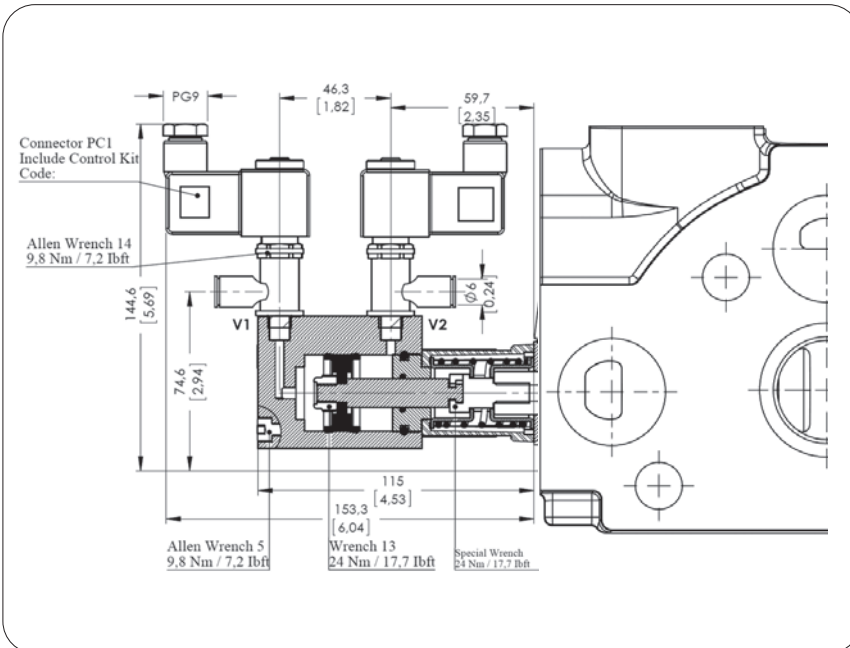

**Operating Features**

Pilot Pressure .....: 6 Bar (Max. 10) / 87 Psi (Max. 145)

**Solenoid Operating Features**

Nominal Voltage.....: 12VDC / 24 VDC

Power Rating.....: 6 W

**INSTALLATION AND MAINTENANCE**

The GMM-DMF valve is assembled and tested as per the technical specification of this catalog. Before the final installation on your equipment, follow the below recommendation:

- The valve can be assembled in any position, in order to prevent body deformation and spool sticking mount the product on a flat surface;
- In order to prevent the possibility of water entering the lever box and spool control kit, do not use high pressure wash down directly on the valve;
- Before painting, ensure plastic port plugs are tightly in place.

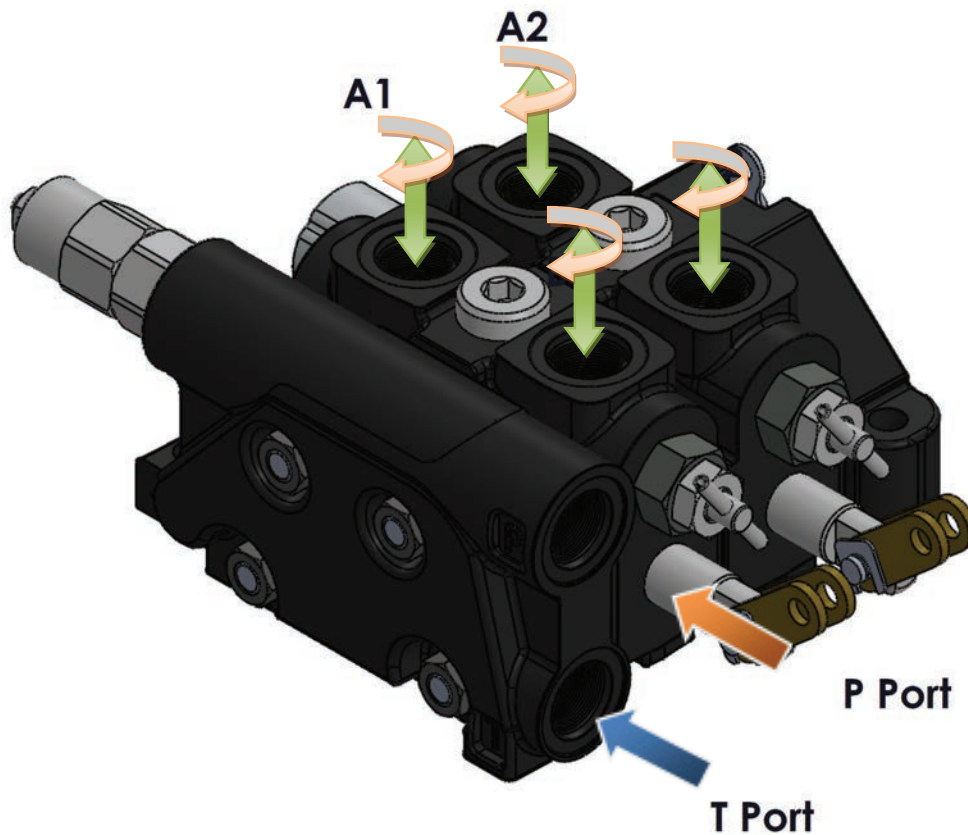

Threads Type (Nm / lbft)	P Port	A and B Port	T Port
BSP (ISO 228/1)	G 1/2	G 1/2	G 1/2
With O--Ring seal	50 / 36.9	50 / 36.9	50 / 36.9
With copper washer	60 / 44.3	60 / 44.3	60 / 44.3
With steel and rubber washer	60 / 44.3	60 / 44.3	60 / 44.3
BSP (ISO 228/1)	G 3/4	G 3/4	G 3/4
With O--Ring seal	70 / 51.6	70 / 51.6	70 / 51.6
With copper washer	70 / 51.6	70 / 51.6	70 / 51.6
With steel and rubber washer	70 / 51.6	70 / 51.6	70 / 51.6
UN--UNF (ISO 11926--1)	9/16--18 UNF--2B	9/16--18 UNF--2B	9/16--18 UNF--2B
With O--Ring seal	30 / 22.1	30 / 22.1	30 / 22.1
METRIC (ISO 262)	M22 x 1.5	M22 x 1.5	M22 x 1.5
With O--Ring seal	50 / 36.9	50 / 36.9	50 / 36.9
With copper washer	60 / 44.3	60 / 44.3	60 / 44.3
With steel and rubber washer	60 / 44.3	60 / 44.3	60 / 44.3



**TECHNICAL DATA**

**Ports Dimensional Data**

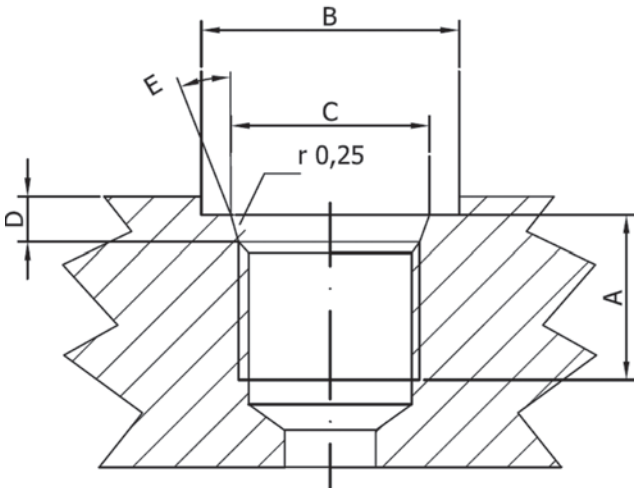

SAE UN-UNF (ISO 725)							
Dimensions		7/8-14 UNF SAE10		1"1/16-12 UN SAE12		1"5/16-12 UN SAE16	
mm	in						
A		17	0,67	20	0,79	20	0,79
B		34	1,34	41	1,61	49	1,92
C		23,9	0,94	29,2	1,15	35,5	1,40
D		2,5	0,10	3,3	0,13	3,3	0,13
E		15°		15°		15°	

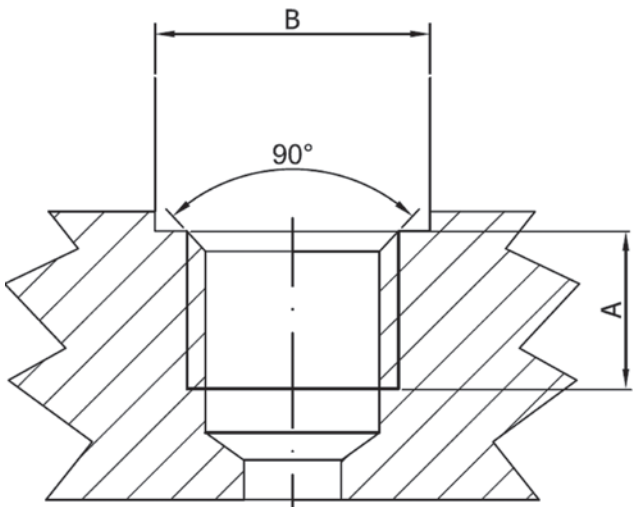

BSP (ISO 228)							
Dimensions		G 1/2"		G 3/4		G 1	
mm	in						
A		16	0,63	18	0,71	20	0,79
B		27	1,06	33	1,30	40	1,57

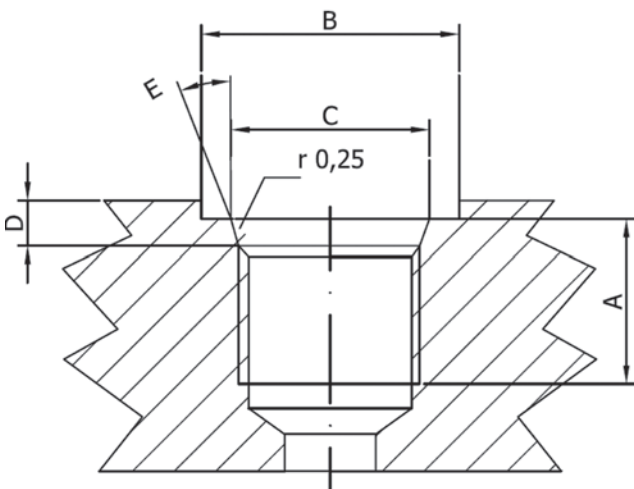

METRIC (ISO 262)							
Dimensions		M22x1,5 ISO 262		M27x2 ISO 262			
mm	in						
A		16	0,63	18	0,71		
B		31,5	1,24	37,7	1,48		



GMM  
DMF

