



MONOBLOCK
DIRECTIONAL
CONTROL VALVES
GMM-M70

CE





CONTENTS

Working Conditions	65
Dimensional Data	66
Hydraulic Circuit	67
Performance Data And Curve	68
Inlet Relief Options	69
Ordering Codes	70
Spool Options	72
Spool Positioners – Side of Return	74
Spool Positioners – Side of Lever Control	78
Spool Positioners – Side of Lever Control	79
Spool Positioners – Side of Lever Control	80
Spool Positioners – Side of Lever Control	81
Complete Control – On / Off Solenoid Control	82
Outlet Port Options	83
Outlet Port Options	84
Installation and Maintenance	85
Technical Data	86

Additional Informations

Note: This catalog shows the product in the most standard configurations. For other configurations, more detailed information or special request, Please contact Customer Service Dpt.

Warning!: All specifications of this catalog refer to the standard product at this date (01/2020). GEMMA, oriented to a continuous improvement, reserves the right to discontinue, modify or revise the specifications, without notice.

GEMMA IS NOT RESPONSIBLE FOR ANY DAMAGE CAUSED BY AN INCORRECT USE OF THE PRODUCT.

WORKING CONDITIONS

Nominal Flow Rating / Displacement	70 l/min	18 U.S.G.P.M
Maximum Working Pressure (Parallel Circuit)	315 Bar	4600 PSI
(Series Circuit)	250 Bar	3600 PSI
Max. Back Pressure	25 Bar	360 PSI
Oil Temperature with NBR Seals	-20 to 80 C°	-4 to 176 F °
with FPM (Viton) Seals	-20 to 100 C°	-4 to 212 F °
Oil Viscosity – Operating Range	From 10 to 75 mm2/s	From 10 to 75 cSt
Minimum / Maximum	10 / 400 mm2/s	10 / 400 cSt
Oil Filtration	≤30 μ	
Ambiant Temperature Range	-35 to 60 C°	-31 to 140 F °
Number Of Spools		1 to 6
Internal Leakage (at 100 bar (1450 PSI), 40C° (110 F°), 46 cSt – A(B)–T)	3 cm3/min	0,18 in3/min
Max. Level Of Contamination	19/16 - ISO 4406	

Not: This catalogue shows technical specifications measured with mineral oil of 46 mm2/s-46 cSt viscosity at 40 C° temperature.

Features

- Simple, compact and heavy duty designed monoblock valves from 1 to 6 sections for open and closed center hydraulic systems.
- Fitted with a main pressure relief valve and a load check valve.
- Optional Carry-Over port only parallel circuit.
- Interchangeable spool diameter is 18 mm – 0,71 in.
- Available manual, pneumatic, hydraulic and electro-pneumatic spool control kits.

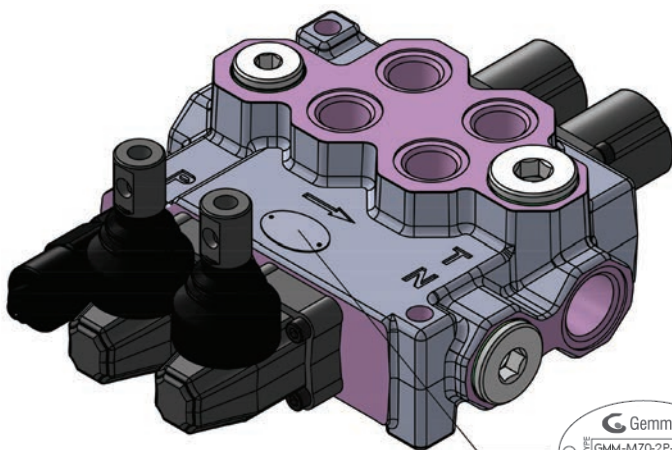

Valve Type
 Production Batch
 39.10 = Production Year - Week (2010/39)
 101149 = Progressive Party Number

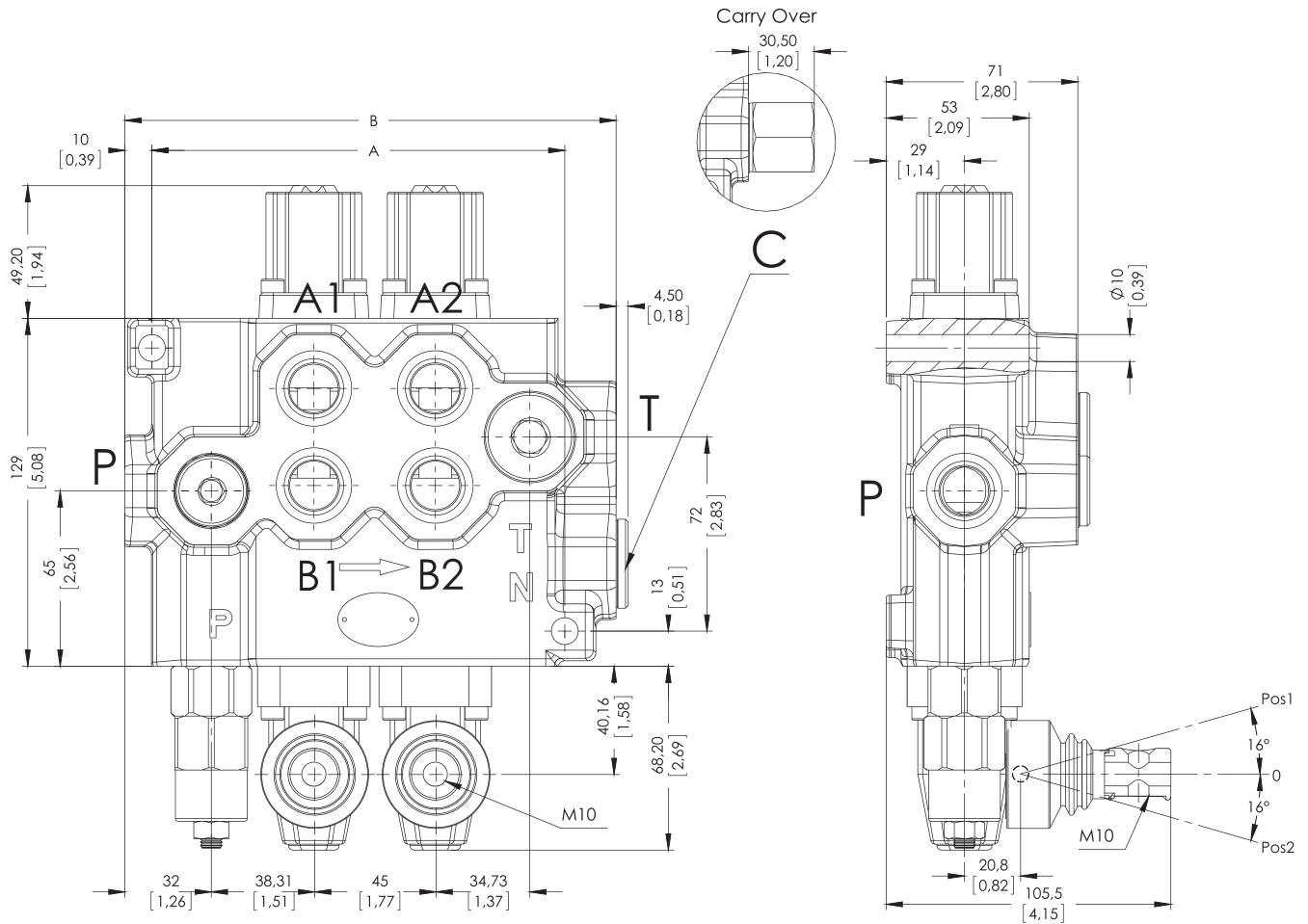
DIMENSIONAL DATA

TYPE	A		B		Weight	
	mm	in	mm	in	Kg	lb
GMM-M70-1P	108	4,25	137	5,40	5,65	12,45
GMM-M70-2P	153	6,03	182	7,17	8,25	18,18
GMM-M70-3P	198	7,80	227	8,94	10,85	23,92
GMM-M70-4P	243	9,57	272	10,72	13,45	29,65
GMM-M70-5P	288	11,35	317	12,49	16,05	35,38
GMM-M70-6P	333	13,12	362	14,26	18,65	41,11

STANDARD THREADS

PORT	BSP (Iso 228)		UN-UNF (Iso 11926-1)	Metric (Iso 262)
	1/2" Series	3/4" Series		
P Inlet	G 1/2	G 3/4	11/16-12 UN	M27x2
A-B Ports	G 1/2	G 3/4	7/8-14 UNF	M22x1.5
T Outlet	G 3/4	G 3/4	11/16-12 UN	M27x2
Pneumatic	G 1/4	G 1/4	NPTF 1/8 - 27	NPTF 1/8 - 27
Carry-Over	G 3/4	G 3/4	11/16-12 UN	G 3/4

HYDRAULIC CIRCUIT

Parallel - Standard Configurations With Side Inlet And Outlet Open Center

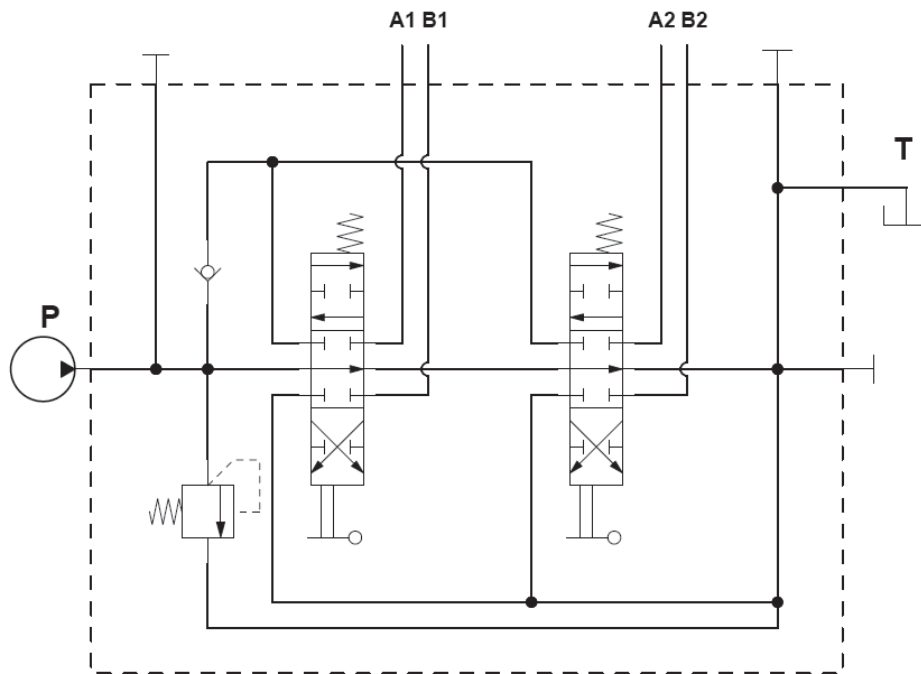
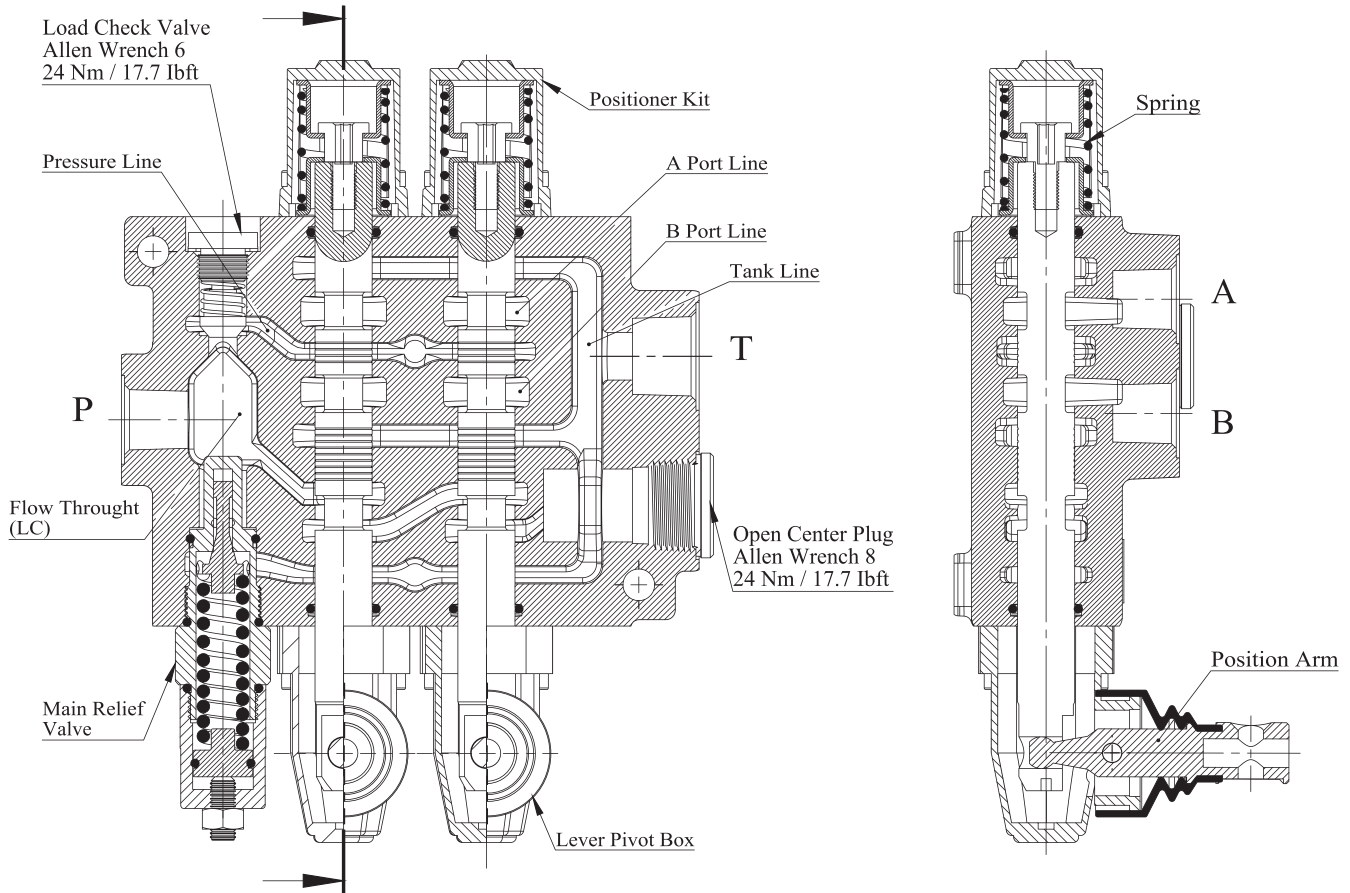

Code: GMM M70-2P / SMR2-120 / 1A-SR-STL/1A-SR-STL/PA1/SGT

PERFORMANCE DATA AND CURVE

Open Center - Pressure Drop (P-T)

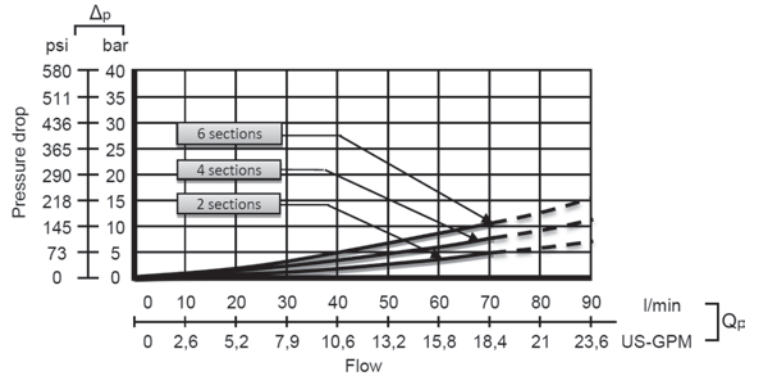
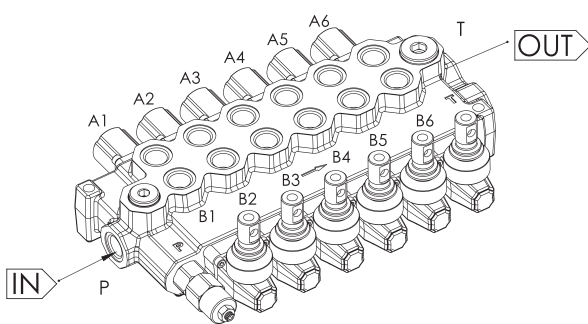

Inlet to Work Port - Pressure Drop (P-A/B)

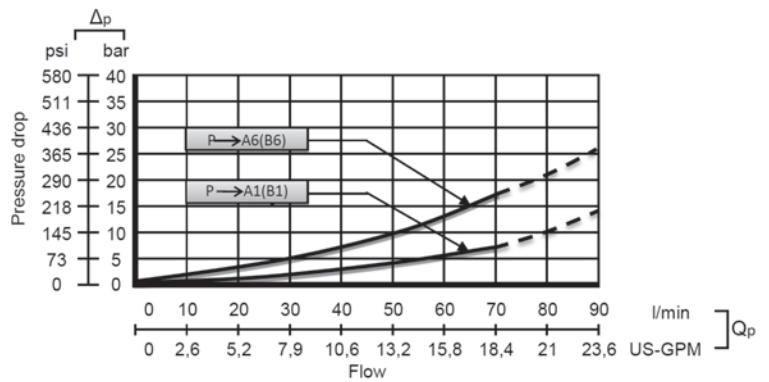
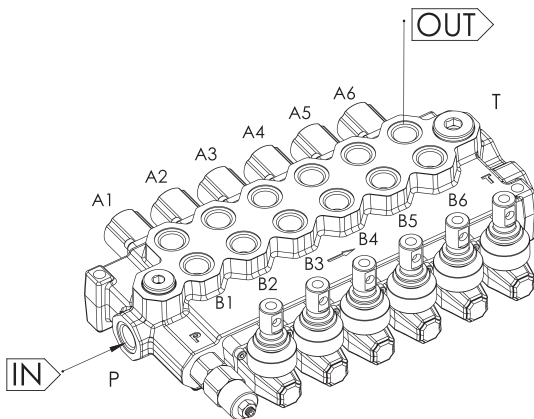

Work Port to Outlet - Pressure Drop (A/B-T)

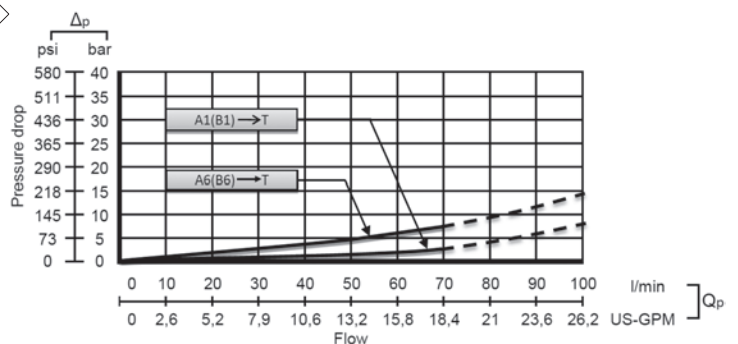
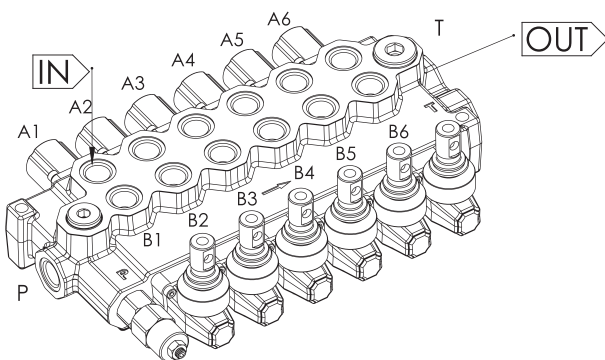

Note: Measured and chart value with spool type 1A.

INLET RELIEF OPTIONS

Direct Pressure Relief Valve

Code:

SMR2 – 120

- Pressure Setting Bar in (Standard 120 bar)
- Standard Main Relief Spring Type -2

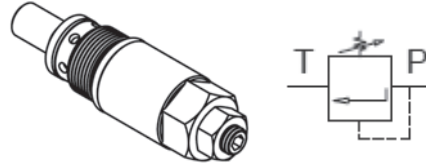

Performance Data

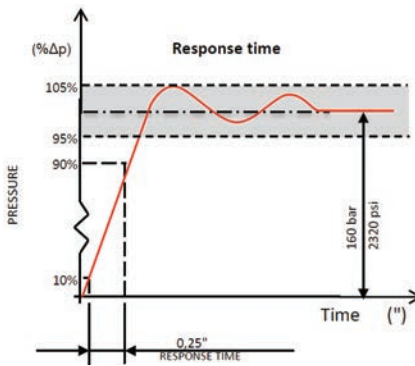
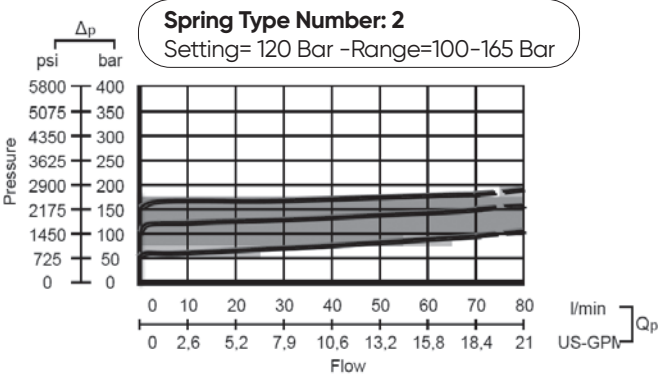
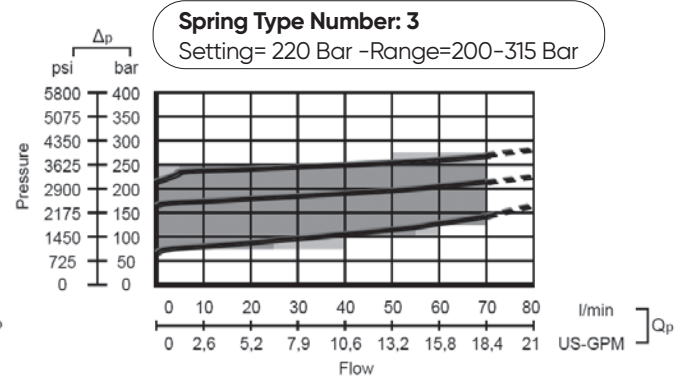
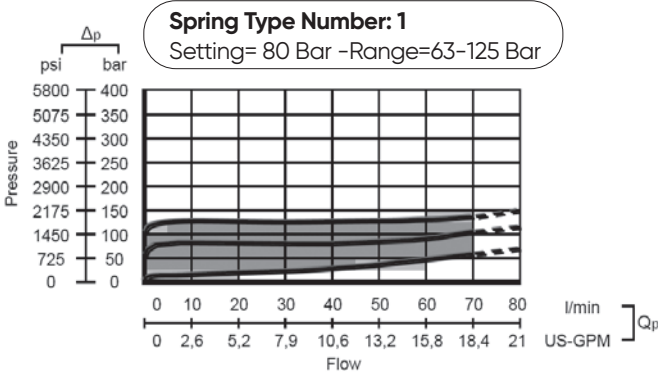

Adjustment Type on Valve

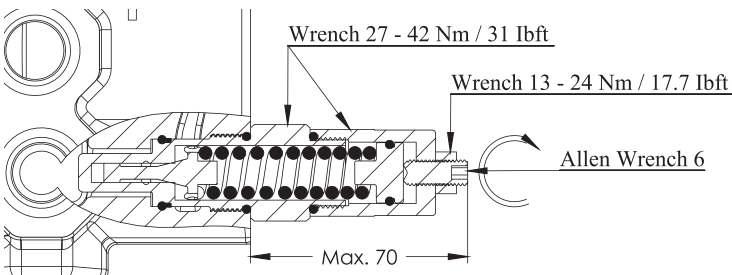

Relief Blanking Plug - WM

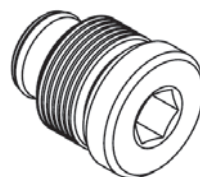
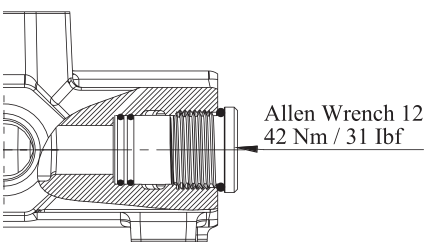

ORDERING CODES

Order Example

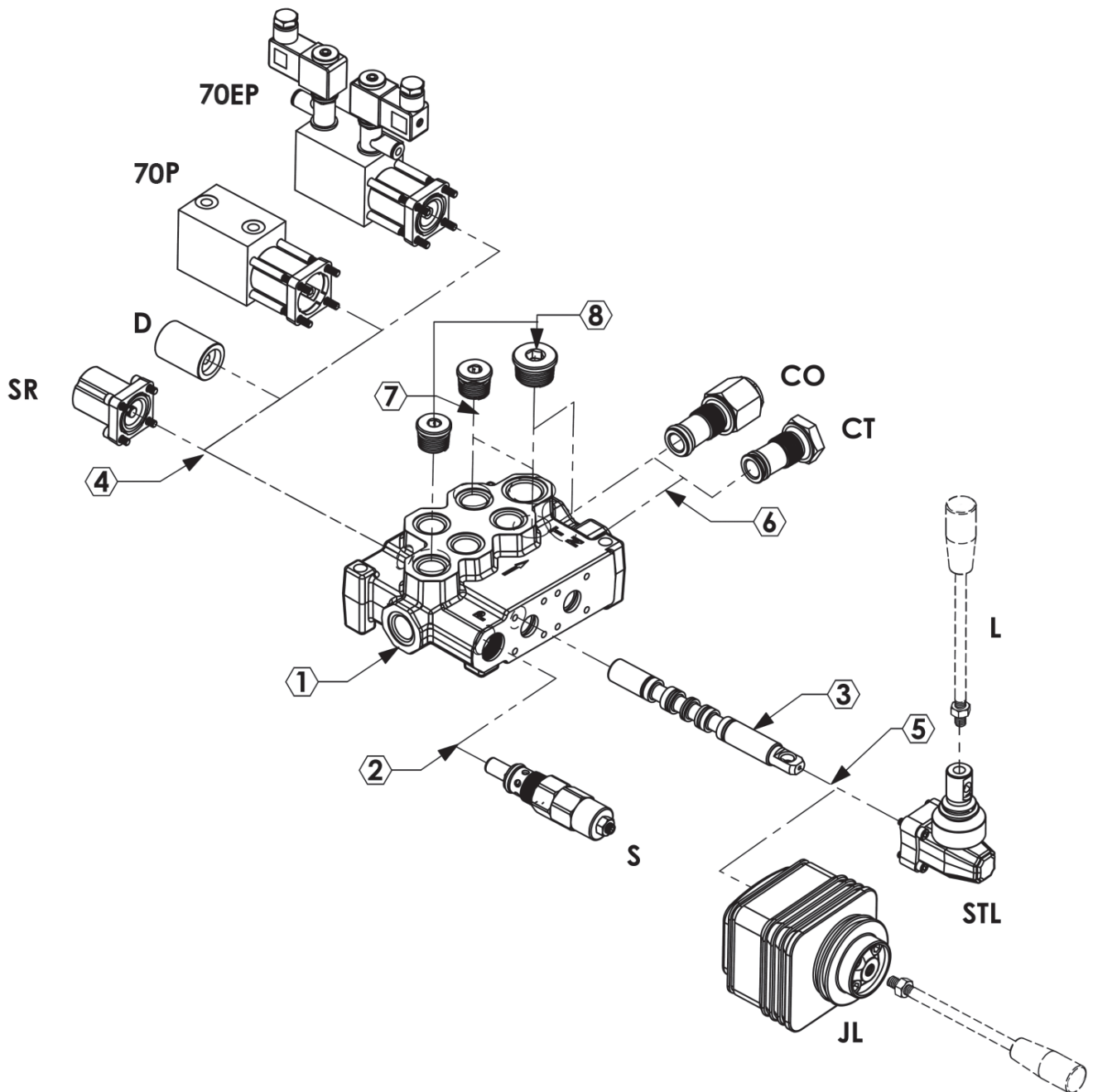
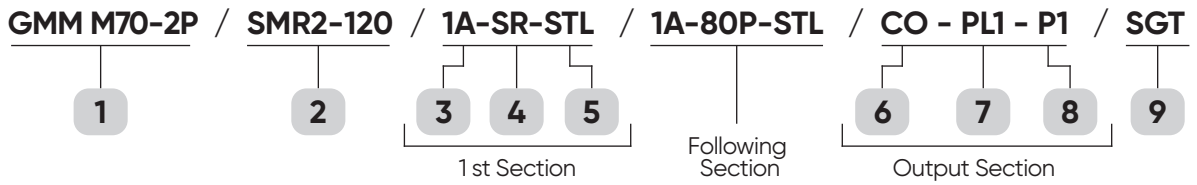

ORDERING CODES

1- Valve Type and Body

- M70 = Valve Type - (M) - Monoblok
(70) - Max. Flow Rate
- 1P** = Body for 1 Section - (1BM170100)
2P = Body for 2 Sections - (1BM270100)
3P = Body for 3 Sections - (1BM370100)
4P = Body for 4 Sections - (1BM470100)
5P = Body for 5 Sections - (1BM570100)
6P = Body for 6 Sections - (1BM670100)

2- Pressure Relief Options

- SMR = Standard direct pressure relief valve
- SMR1-080** - (2SMR170080) - Range 63-125 bar
Setting 80 bar
- SMR2-120** - (2SMR270120) - Range 100-165 bar
Setting 120 bar
- SMR3-220** - (2SMR370220) - Range 200-315 bar
Setting 220 bar

3- Spool Options

- 1A - (3SM170110) - 3 Positions ,Double acting
 2A - (3SM170120) - 3 Positions ,Double acting
 A to tank B Blocked
- 3A - (3SM170130) - 3 Positions ,Double acting
 B to tank A blocked
- 4A - (3SM170140) - 3 Positions ,Double acting
 A and B tank
- 5A - (3SM170150) - 3 Positions ,Single acting on
 A (A to tank)
- 6A - (3SM170160) - 3 Positions ,Single acting on
 B (B to tank)

4- Spool Positioners

- SR = Spring Return in neutral position - (4SR080100)
 D = Detent in position 1, neutral and 2 - (4D080100)
- 80P = ON/OFF Pneumatic - (445P045100)
 80EP = 12 VDC ON/OFF electro-pneumatic -
 (480EP080112)
- 80EH = 12 VDC/24 VDC ON/OFF electro-hydraulic
 (3645EH100112)

5- Lever Options

- STL** = Standard lever - (5STL080100)
JL = Joystick lever for two sections operation
 - (5JL 080100)

6- Output Options

- PA2(T)** = G3/4 Top output plug - (6PL1080134)
PA2(S) = G3/4 Side output plug - (6PL1080134)
CO = G3/4 Carry-Over Connector - (6CO080100)
CT = G3/4 Carry-Over Plug - (6CT070100)

7- Ports Plug Options "If Required"

- PL3(5A)** = Plug for single action spool for 5A
 G3/4 - (6PL1080134)
- PL3(6A)** = Plug for single action spool for 6A
 G3/4 - (6PL1080134)
- PL2(5A)** = Plug for single action spool for 5A
 G1/2 - (6PL1040112)
- PL2(6A)** = Plug for single action spool for 6A
 G1/2 - (6PL1040112)

*Page 12 for detail spool options.

8- Ports Input Plug Options

- PI1(T)** = G1/2 Top input - (6PL1040112)
PI1(S) = G1/2 Side input - (6PL1040112)
PI3(T) = G3/4 Top input - (6PL1080134)
PI3(S) = G3/4 Side input - (6PL1080134)

9- Ports Thread Options

- SGT1** = 1/2" Series Port Options - (9P045112)
SGT3 = 3/4" Series Port Options - (9P080134)
UNF = UNF Series Port Options - (9U045138)
M = Metric Series Port Options - (9M045138)

*Page 4 for detail port information.

HandLever

- L** = Standard HandLever (L=120mmxM8) - (7L040100)
HL = Remote Cable Kit - (80HL80100)

SPOOL OPTIONS

Spool Type - 1A

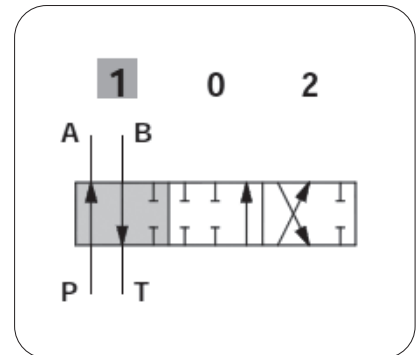
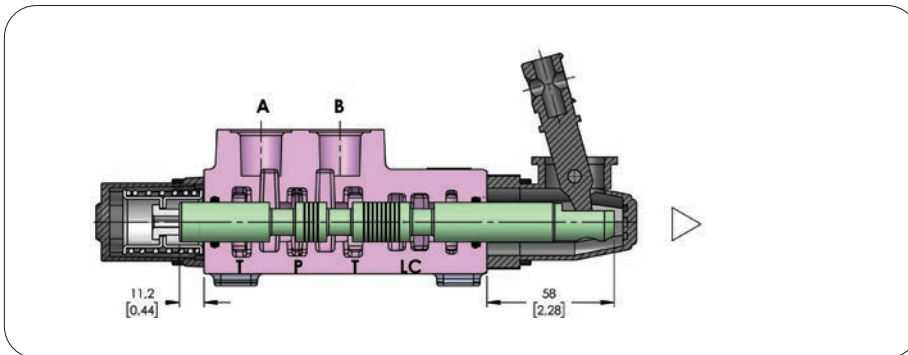
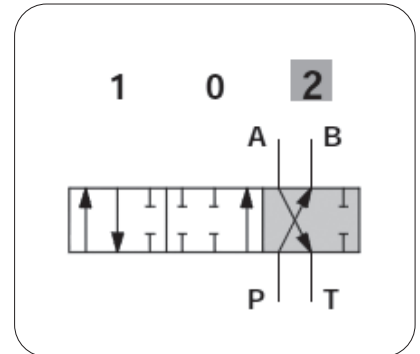
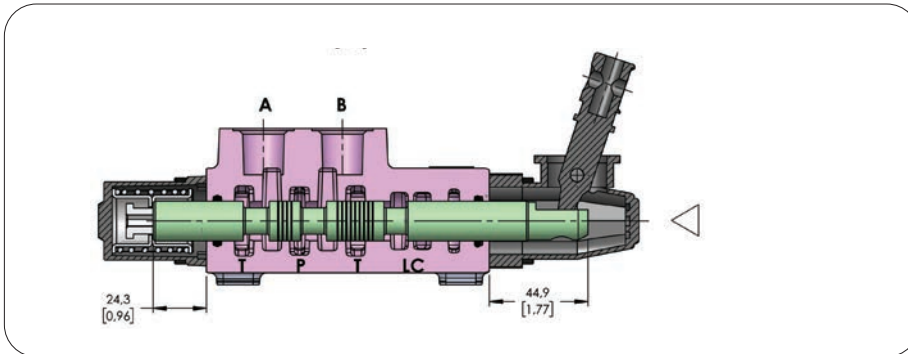
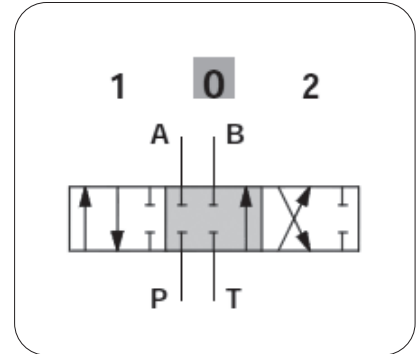
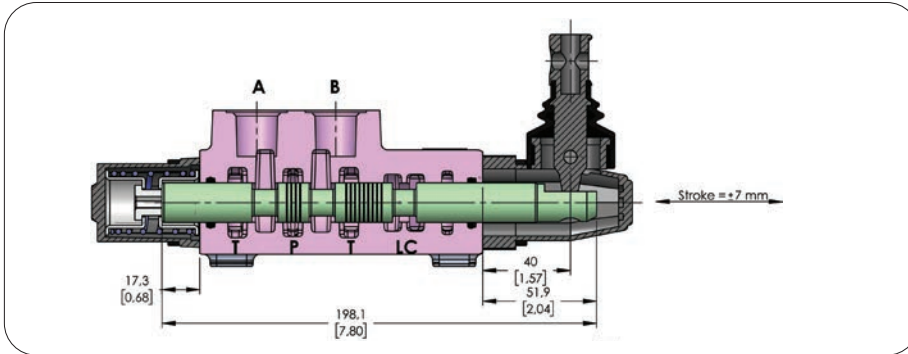

Performance Curve And Data

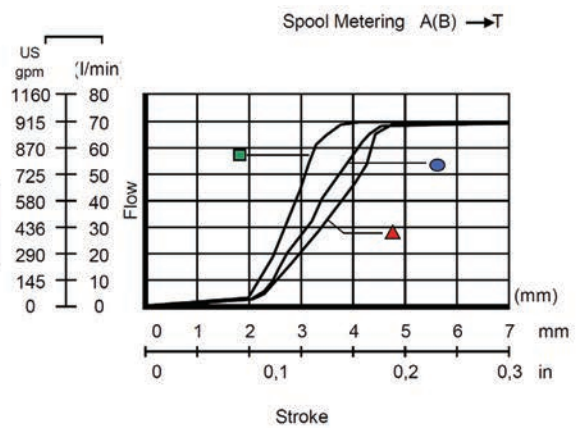
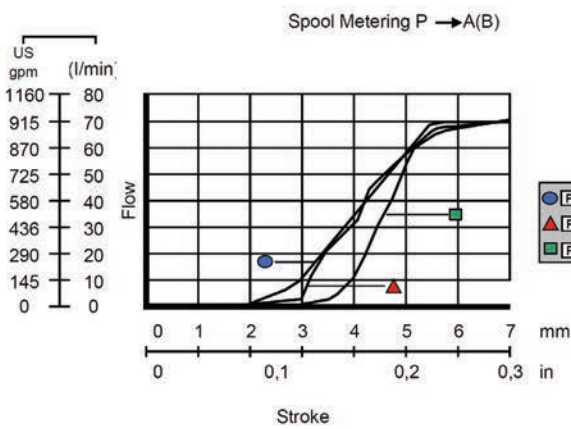

SPOOL OPTIONS

Spool Type - 2A

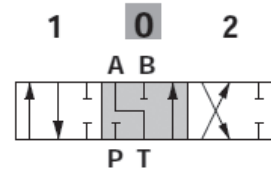
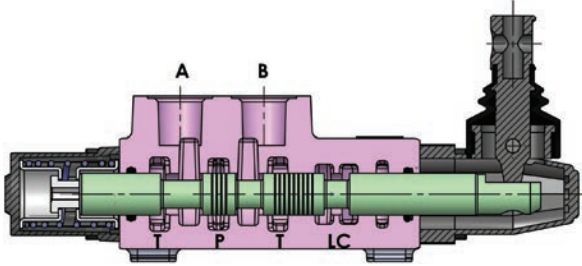

Spool Type - 3A

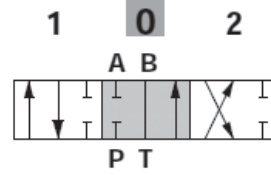
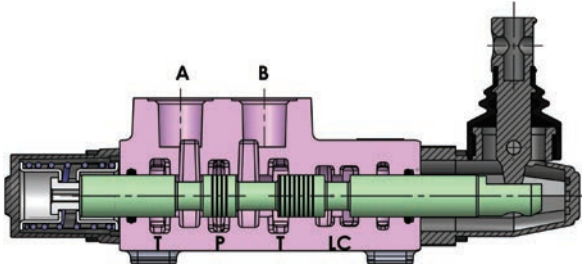

Spool Type - 4A

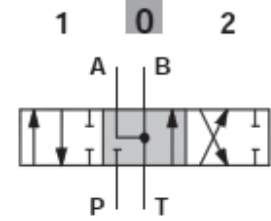
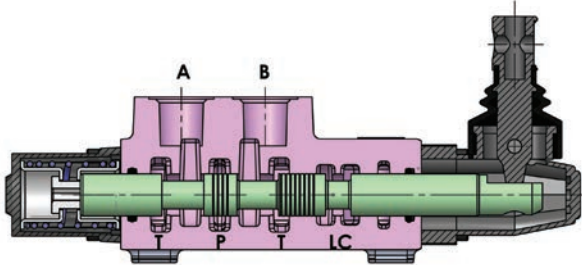

Spool Type - 5A

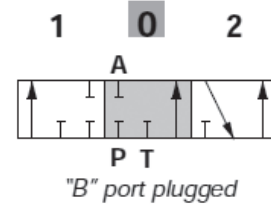
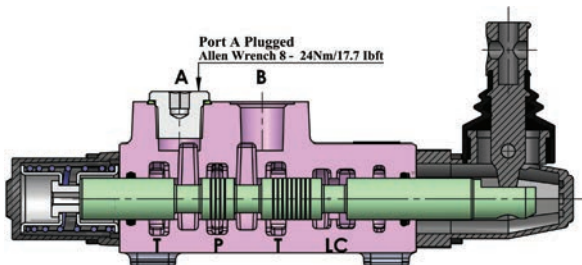

Spool Type - 6A

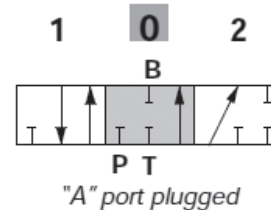
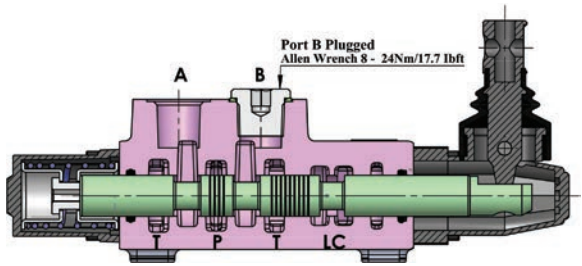

SPOOL POSITIONERS – SIDE OF RETURN

With Spring Return in Neutral Position

Kit No: **SR**

Sectional Appearance

Diagram

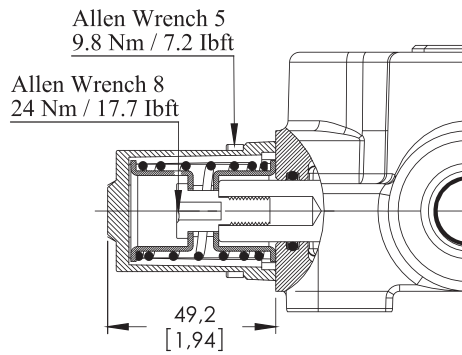

With Detent

Kit No: **D**

Sectional Appearance

Diagram

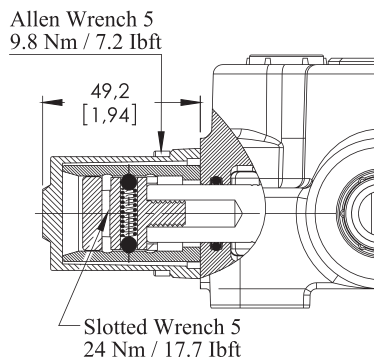

Force - stroke diagram

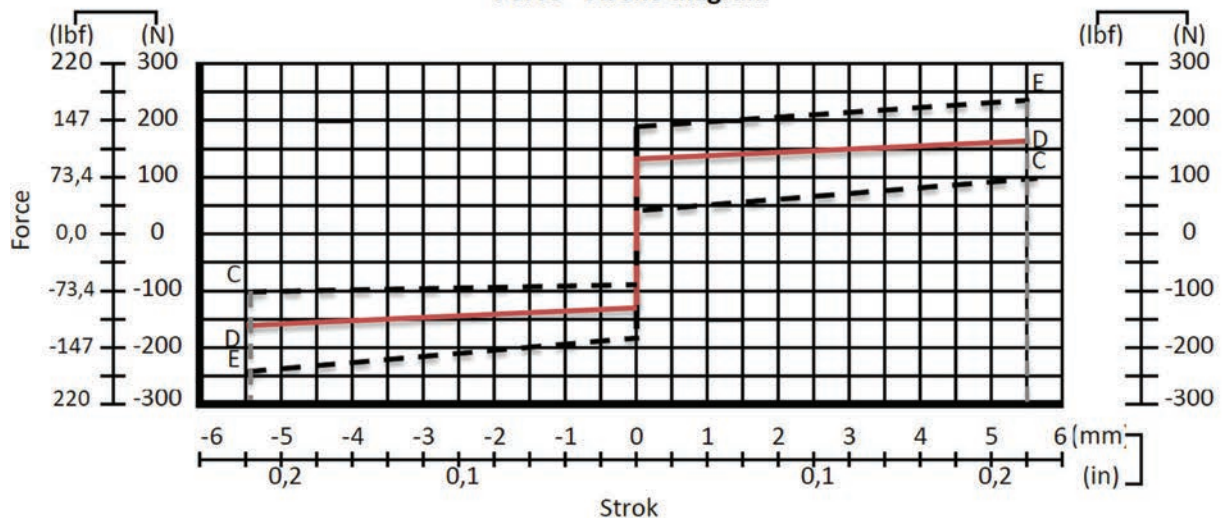

SPOOL POSITIONERS – SIDE OF RETURN

ON/OFF Pneumatic Control

Kit No: **70P**

Sectional Appearance

Diagram

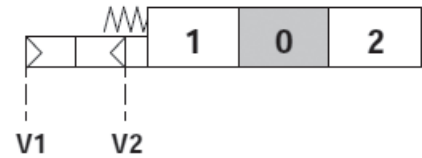
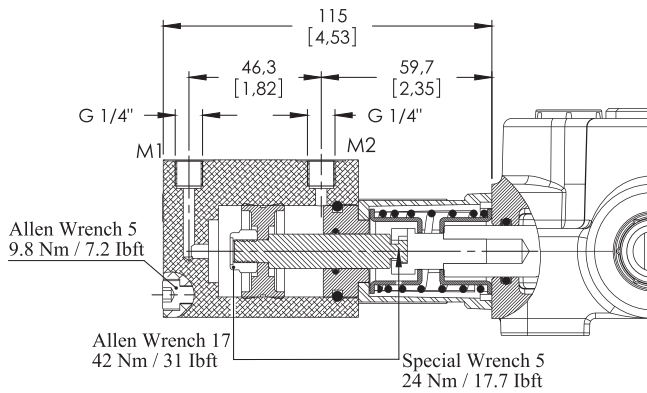

Operating Features

Pilot Pressure: 6 Bar (Max. 10) / 87 Psi (Max. 145)

ON/OFF Electro-Pneumatic Control

Kit No: **70EP**

Sectional Appearance

Diagram

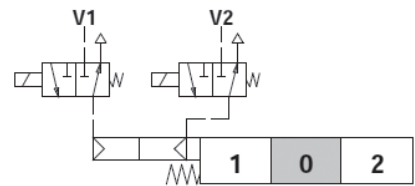
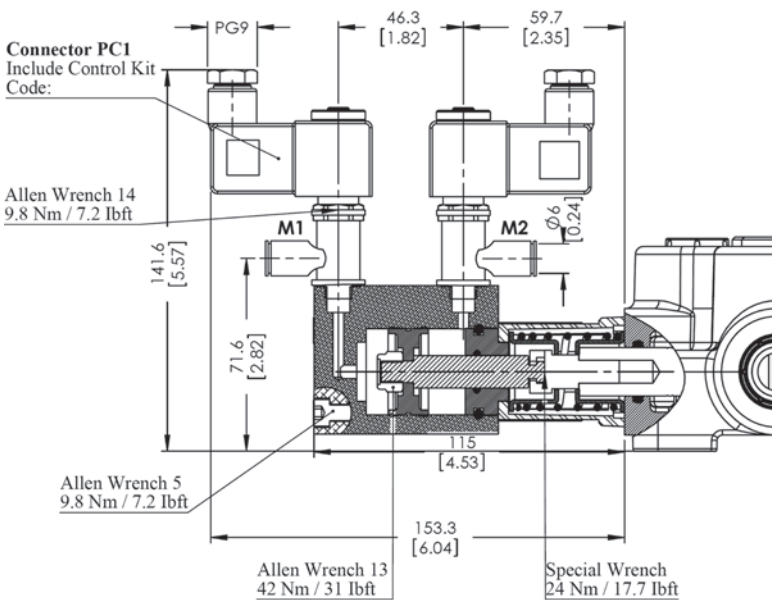

Operating Features

Pilot Pressure: 6 Bar (Max. 10) / 87 Psi (Max. 145)

Solenoid Operating Features

Nominal Voltage.....: 12VDC / 24 VDC

Power Rating.....: 6 W

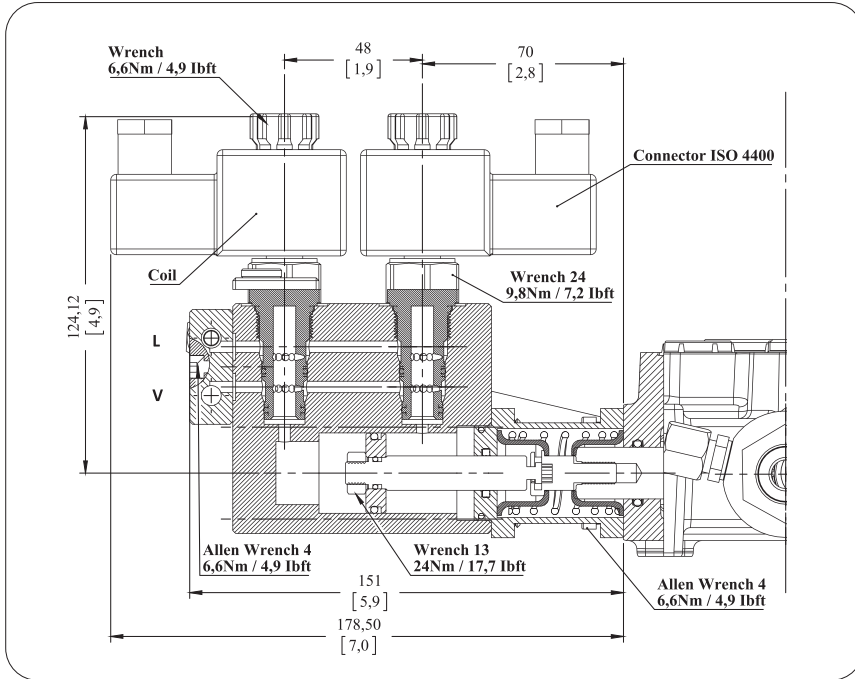
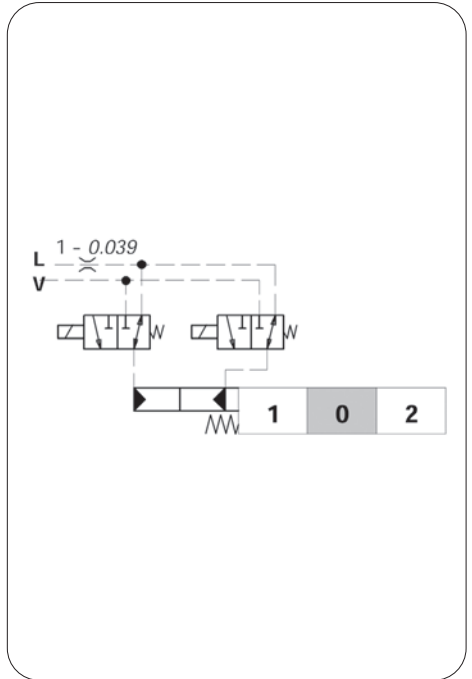
SPOOL POSITIONERS – SIDE OF RETURN
ON/OFF Electro - Hydraulic Control
Kit No: 70EH
Sectional Appearance

Diagram

Operating Features

Pilot Pressure: 10 Bar / 145 Psi
 : 50 Bar / 725 Psi
 Max back pressure on drain L.....: 25 Bar / 360 Psi

Solenoid Operating Features

Coil Connection.....: ISO 4400
 Nominal voltage.....: 12 VDC / 24 VDC
 Power rating.....: 21 W
 Duty cycle.....: %100
 Protection type.....: IP 65
 Nominal voltage tolerance.....: ±10
 Max temperatures.....: 100 C°
 Stroke.....: ±5,5 mm

ORDER CODE
External Pilot Collector

COL 11 - 10COL1001 – Kit For Section 1
 COL 12 - 10COL1001 – Kit For Section 2
 COL 13 - 10COL1001 – Kit For Section 3
 COL 14 - 10COL1001 – Kit For Section 4
 COL 15 - 10COL1001 – Kit For Section 5
 COL 16 - 10COL1001 – Kit For Section 6
 COL 17 - 10COL1001 – Kit For Section 7
 COL 18 - 10COL1001 – Kit For Section 8

Standard Pilot Collector

COL 21 - 10COL2001 – Kit For Section 1
 COL 22 - 10COL2001 – Kit For Section 2
 COL 23 - 10COL2001 – Kit For Section 3
 COL 24 - 10COL2001 – Kit For Section 4
 COL 25 - 10COL2001 – Kit For Section 5
 COL 26 - 10COL2001 – Kit For Section 6
 COL 27 - 10COL2001 – Kit For Section 7
 COL 28 - 10COL2001 – Kit For Section 8

SPOOL POSITIONERS – SIDE OF RETURN

ON/OFF Electro - Hydraulic Control Connections

Connection Type 1: Collector kit for external pilot and drain

Sectional Appearance

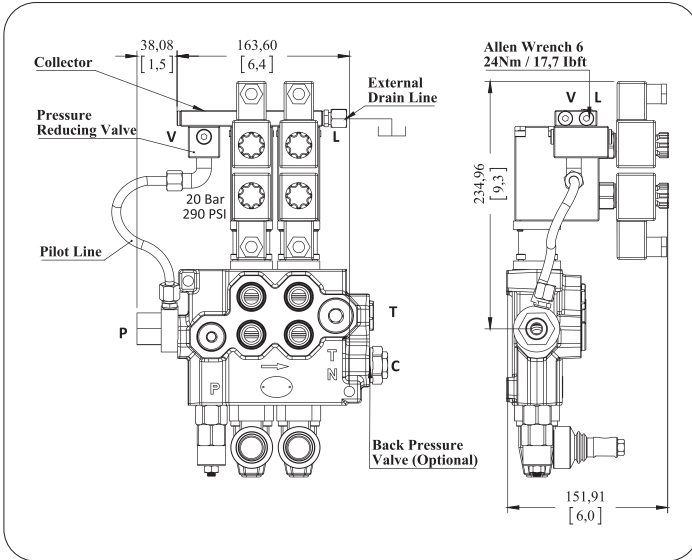

Diagram

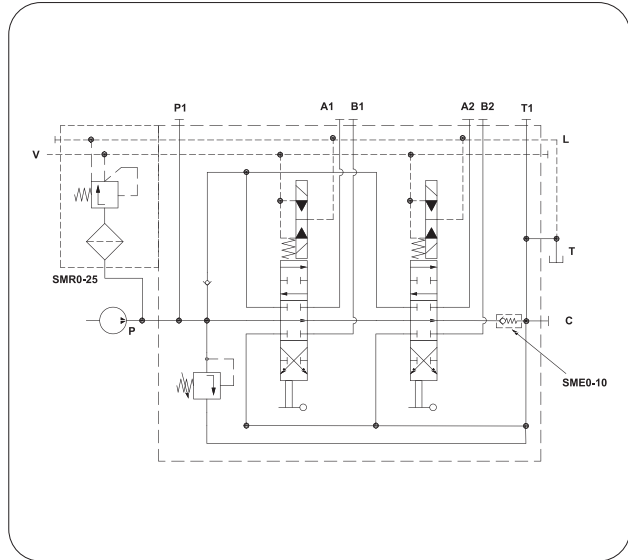

Operating Features

External Pressure Reducing Valve: 20 Bar / 290 Psi (For V line)

Code= GMM M70-2P (SD(LA)-SMR2-125-PP)/P-1A-STL-70EH/ P-1A-STL-70EH (SMR0 -COL12-12V)/ SO-PT1 / SGT

Connection Type 2: Collector kit with pilot and drain lines

Sectional Appearance

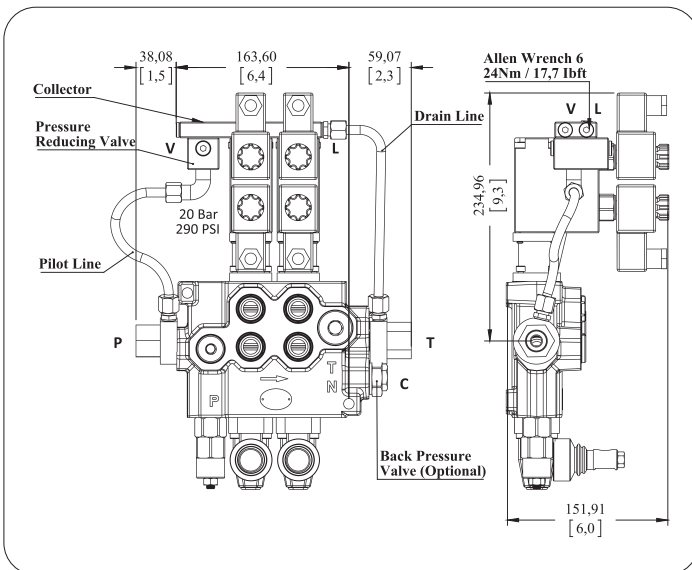

Diagram

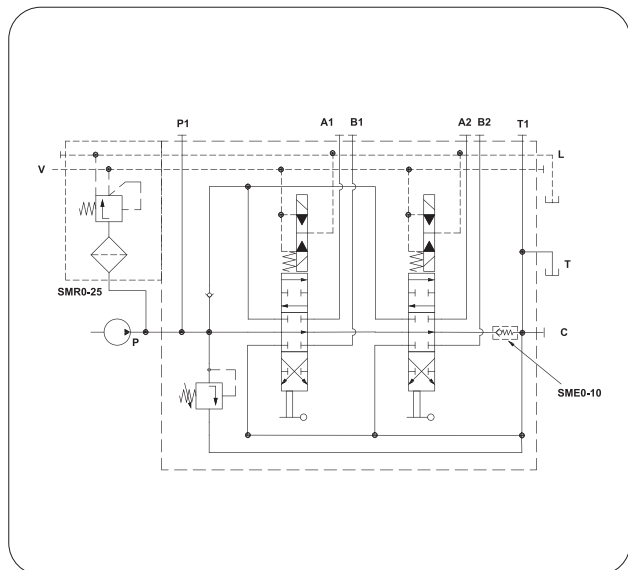

SMR 0-25 Valve Operating Features (Pressure reducing valve)

Outlet Pressure: 20 Bar / 290 Psi

Max. Flow.....: 8 l/min

Filtering: 80 μ

Code = GMM M70-2P (SD(LA)-SMR2-125-PP)/P-1A-STL-70EH/ P-1A-STL-70EH (SMR0 -COL22-12V)/ SO-PT1 / SGT

SPOOL POSITIONERS – SIDE OF LEVER CONTROL

Lever Controls

Kit No: **STL - L0**

Sectional Appearance

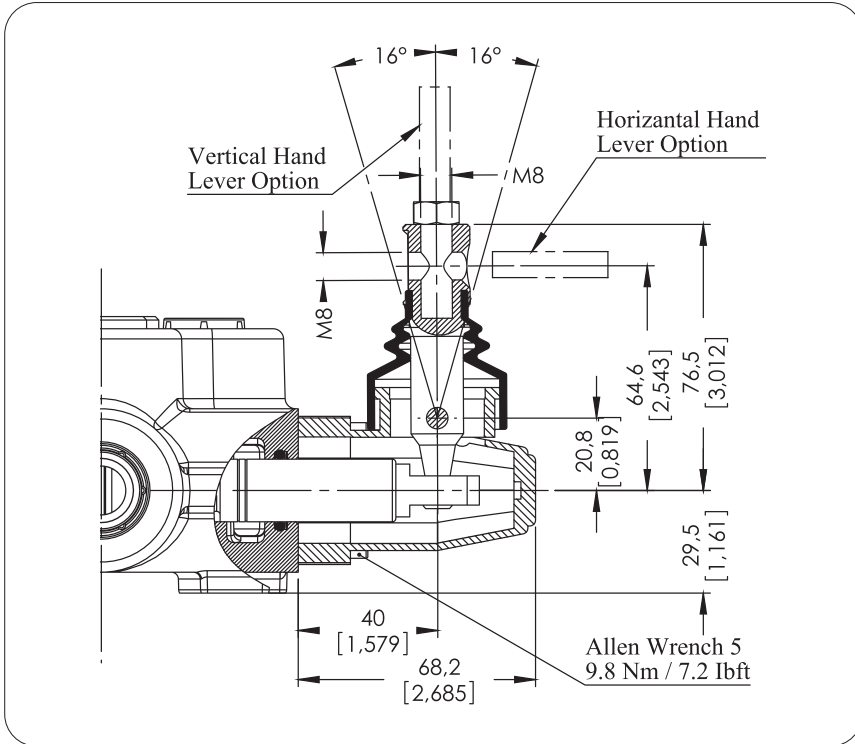

Diagram



Kit No: **STL - L180**

Sectional Appearance

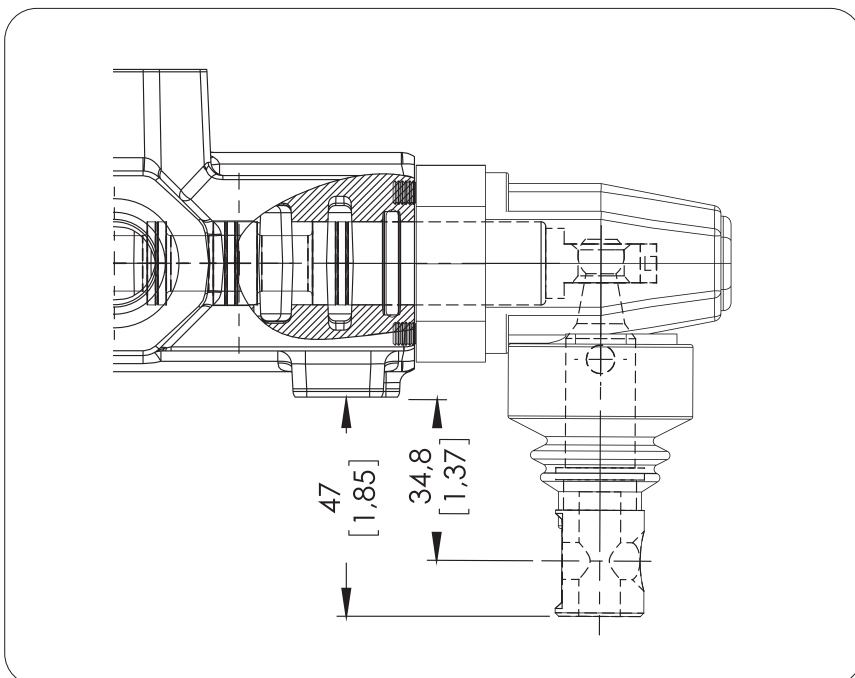

Diagram

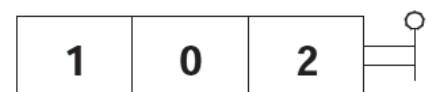

Note: Aluminium protected arm lever pivot box can be rotated 180°.

SPOOL POSITIONERS – SIDE OF LEVER CONTROL

Lever Controls - Joystick

Kit No: **JL**

Exploded View

Diagram

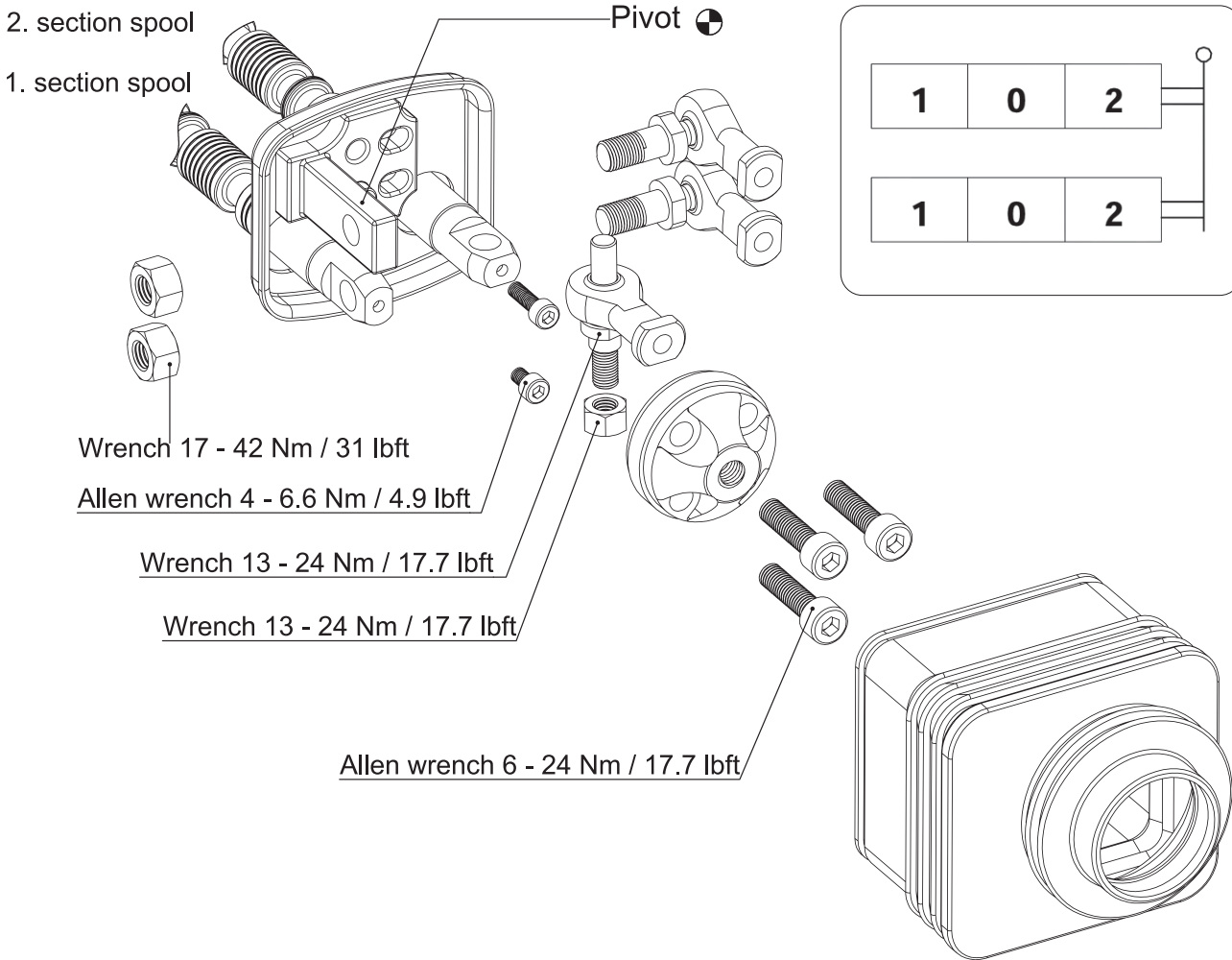

Operation Angle:

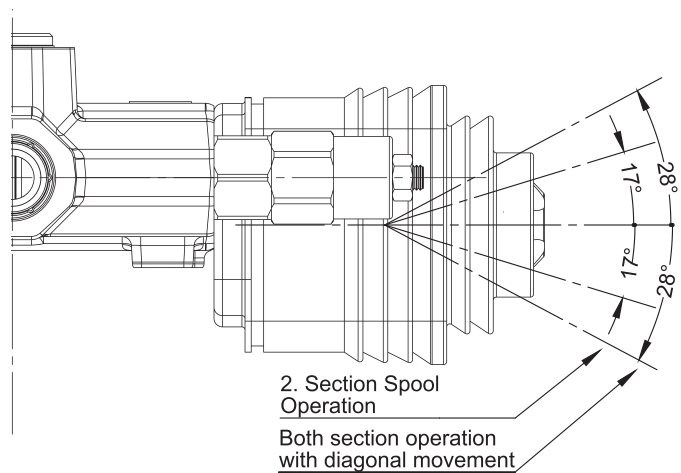
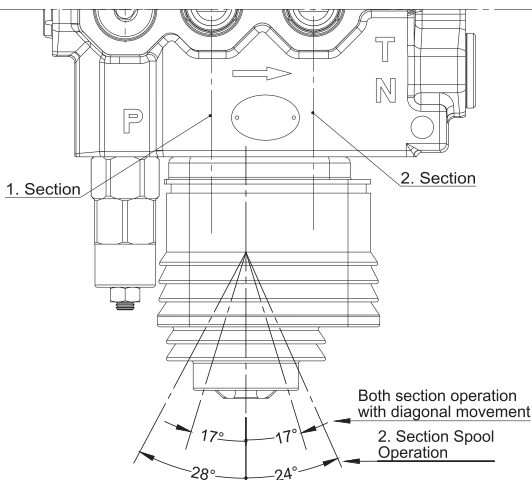

SPOOL POSITIONERS – SIDE OF LEVER CONTROL
Lever Controls - Joystick
Dimensions and movement scheme

 Type No: **JL1**

Application: Pivot placed down on the Left

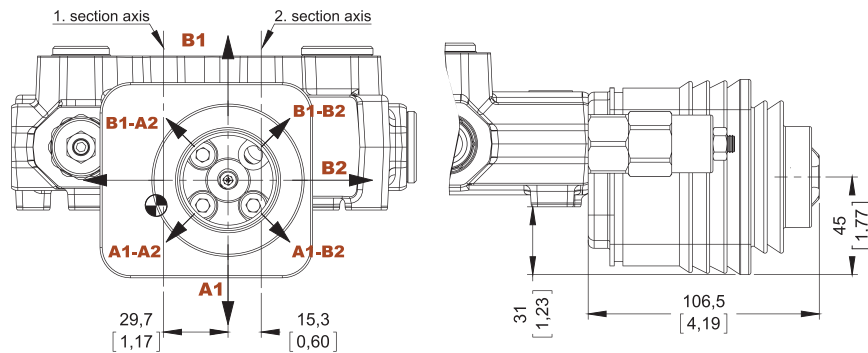
 Type No: **JL2**

Application: Pivot placed down on the right

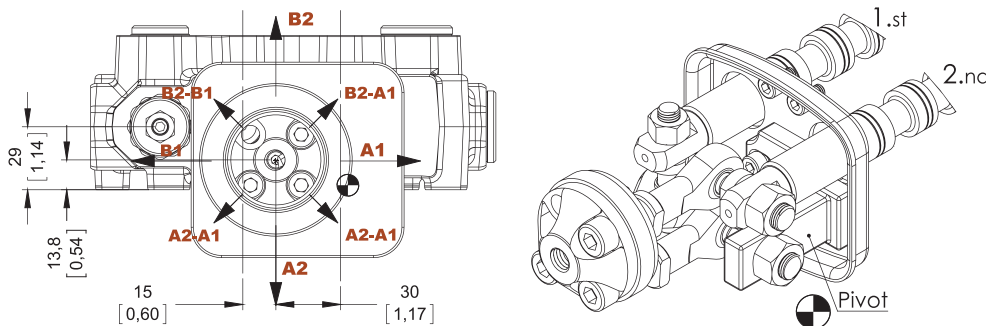
 Type No: **JL3**

Application: Pivot placed above on the Left

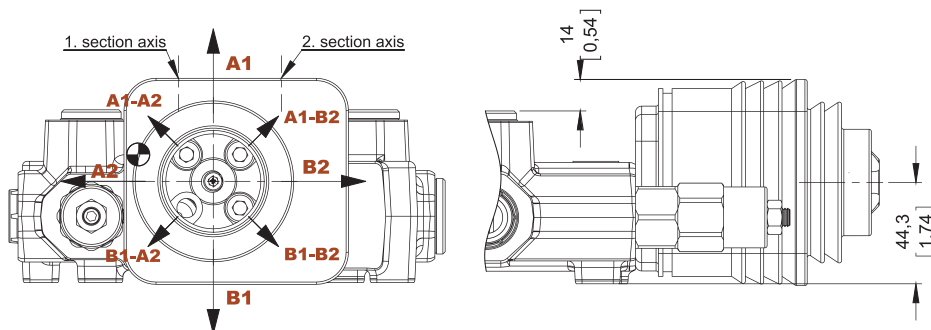
 Type No: **JL4**

Application: Pivot placed above on the right

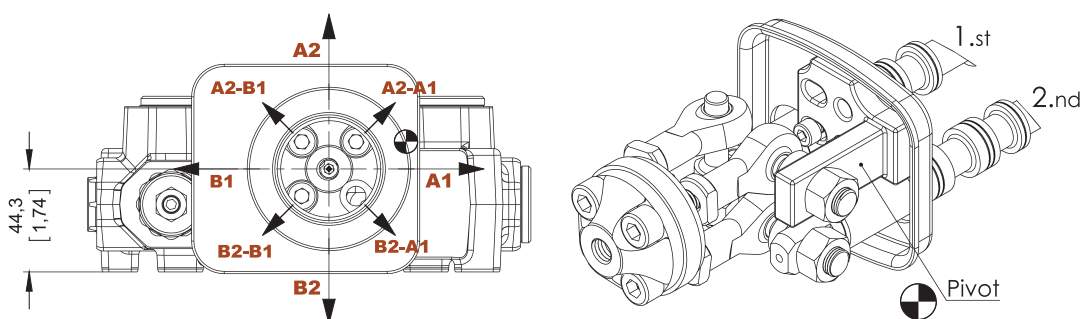

SPOOL POSITIONERS – SIDE OF LEVER CONTROL

Lever Controls – Cable Control

Kit No: HL

Exploded View

Diagram

Waterproof cap prearranged for remote control with flexible cable.

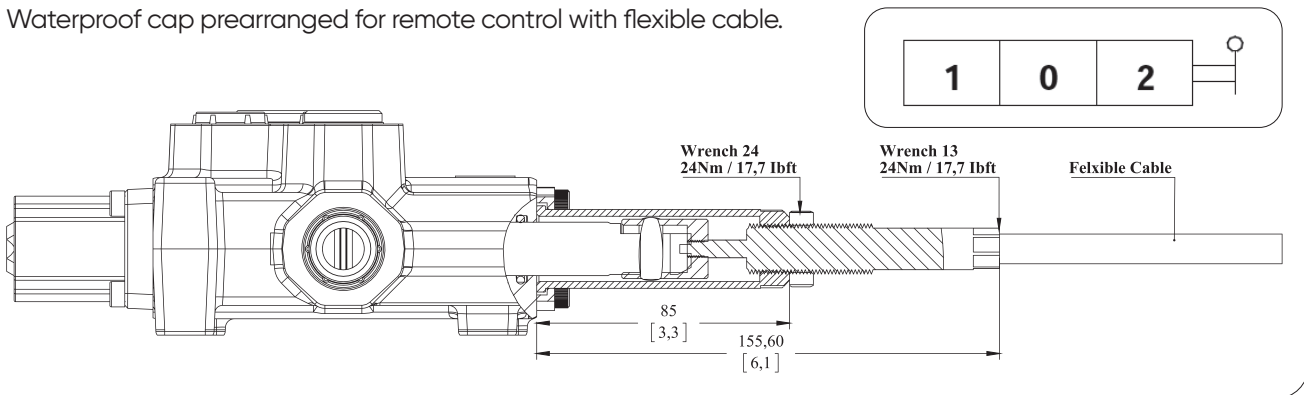

Note: Remote cable control is several options. Please indicate the cable length demanded and contact our sales department.

Example Operation

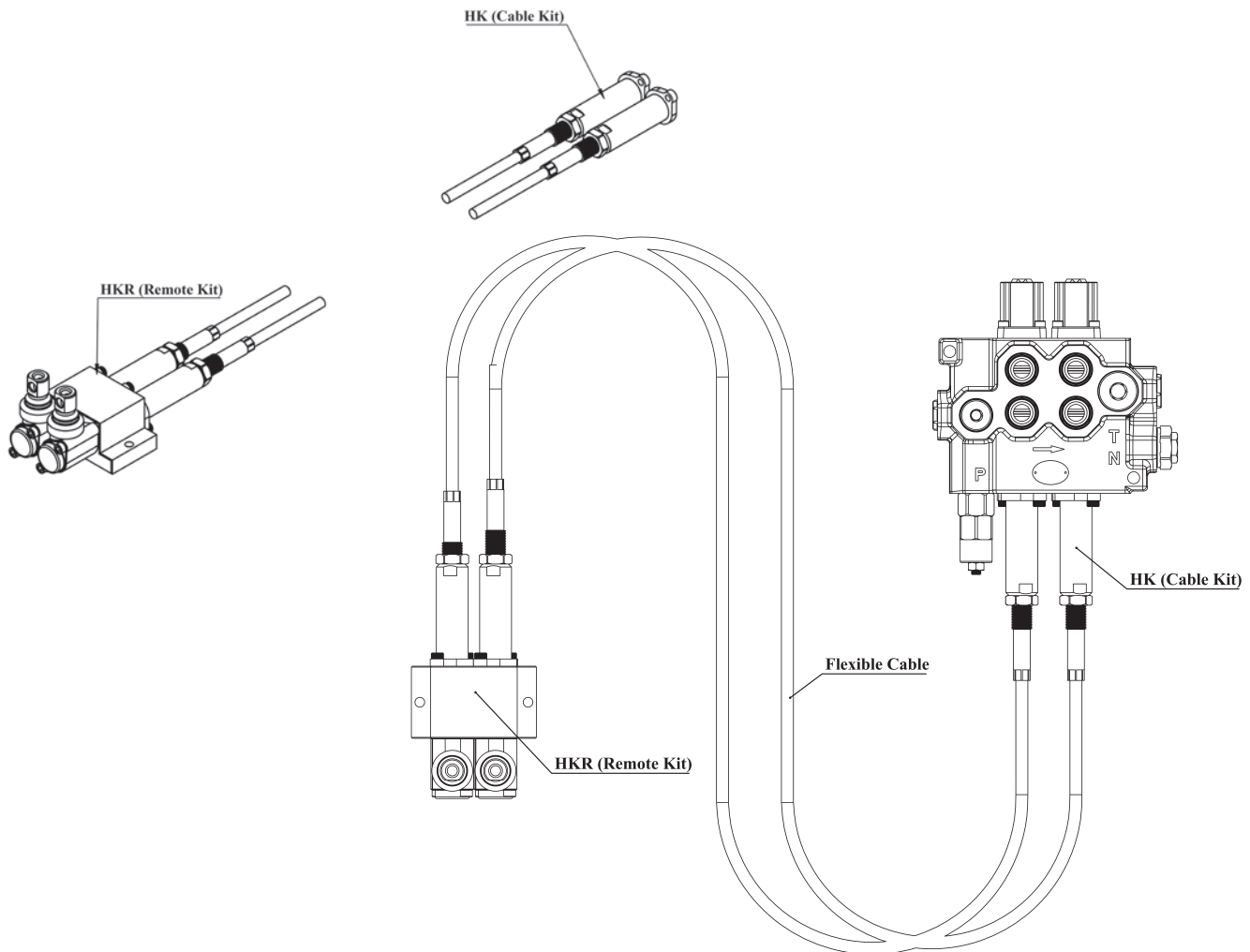

COMPLETE CONTROL – ON / OFF SOLENOID CONTROL

ON/OFF Solenoid Control

Kit No: **SEC**

Sectional Appearance

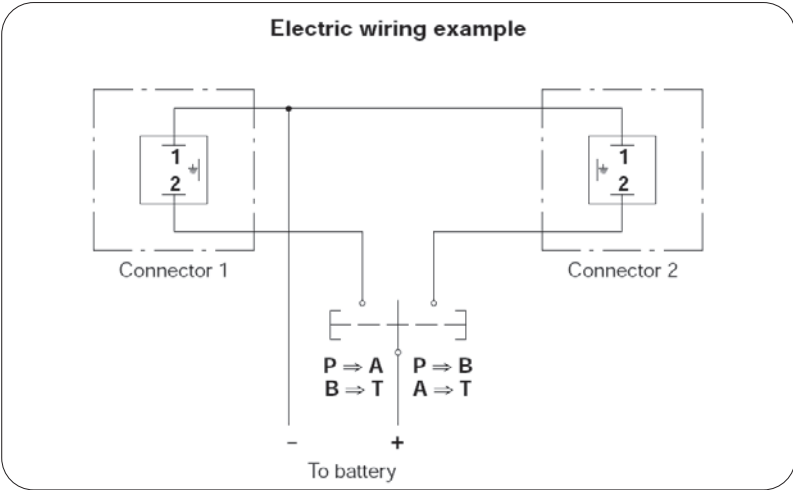

Diagram

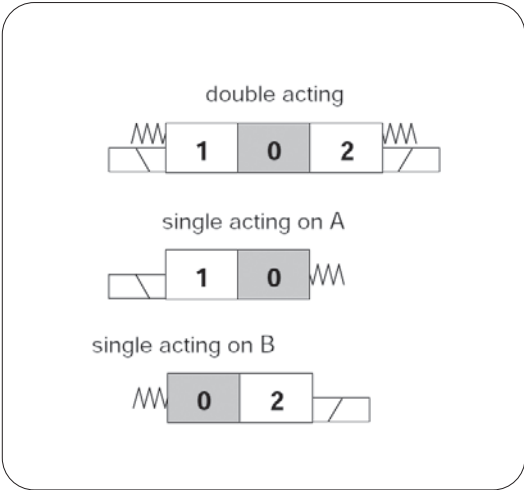

Operating Features
 Max Working Pressure.....: 230 Bar / 3300 Psi
 Max back pressure: 5 Bar / 80 Psi
 Internal Leakage.....: 10 cm³ / min

Solenoid Operating Features
 Nominal voltage.....: 12 VDC / 24 VDC
 Power rating.....: 36 W
 Duty cycle.....: %100
 Nominal voltage tolerance.....: ±10

Coil insulation: Class H
 Stroke.....: ±3

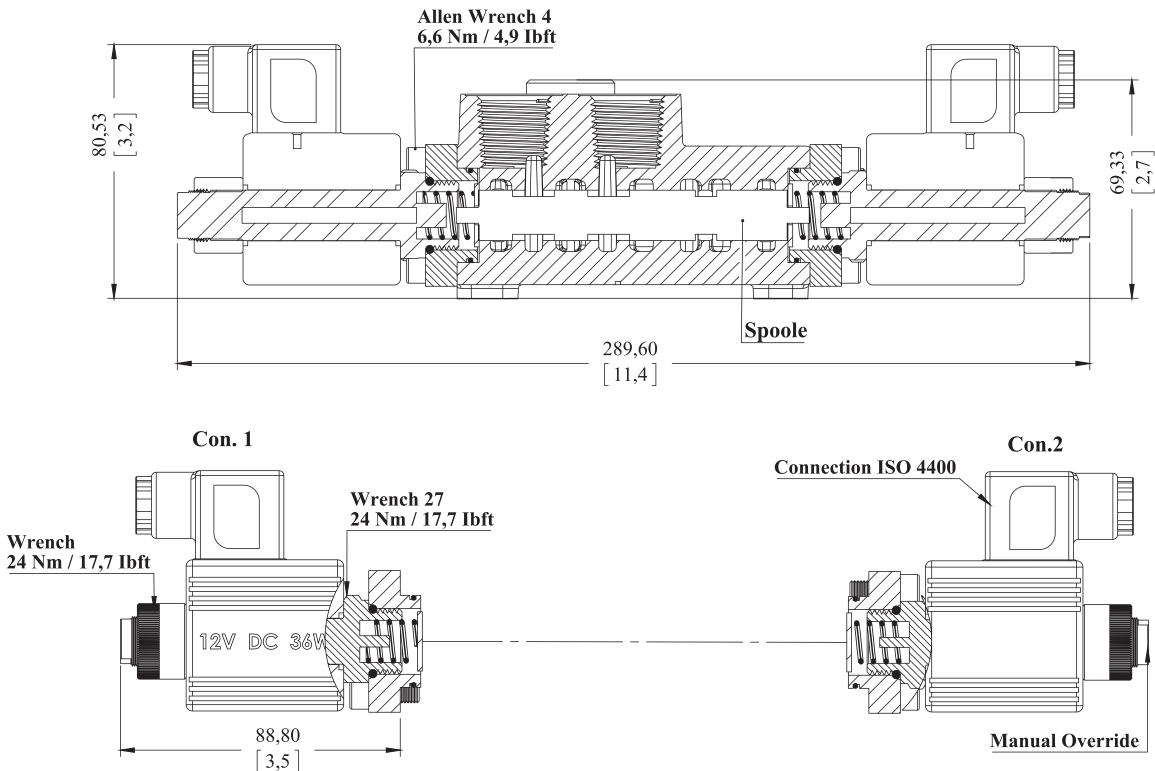

OUTLET PORT OPTIONS

Carry - Over Connection

Kit No: CO

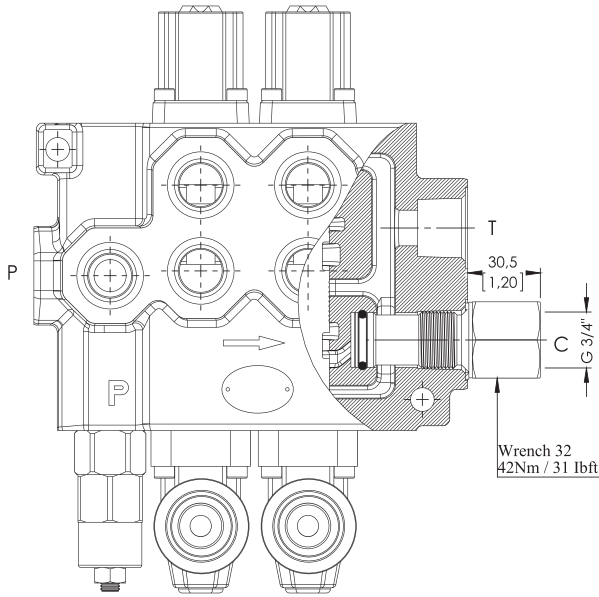

Sectional Appearance

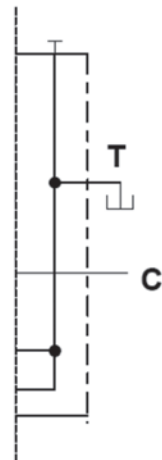

Hydraulic Circuit

Code: GMM M70-2P / SMR2-120 / 1A-SR-STL/1A-SR-STL/CO-PA1/SGT

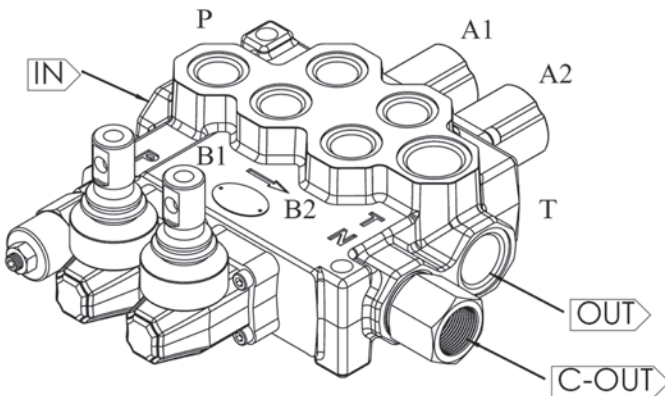

Direction of Port Connected

SGT : See page 5 for Standard center

OUTLET PORT OPTIONS

Closed Center

Kit No: CS

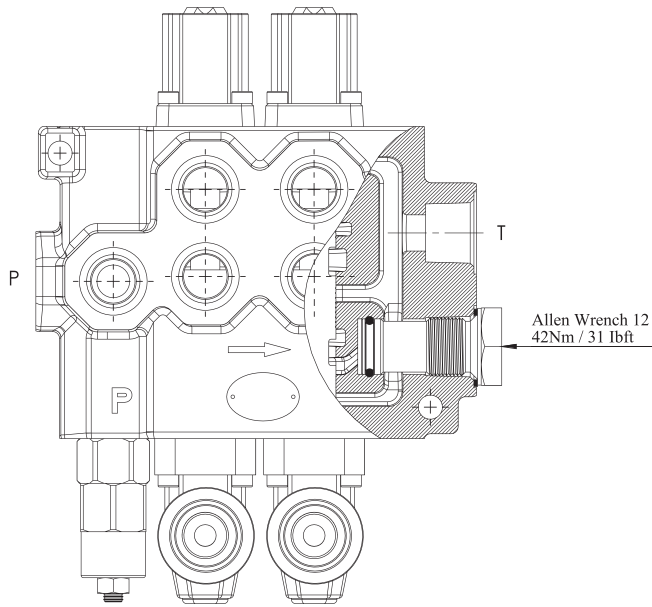

Sectional Appearance

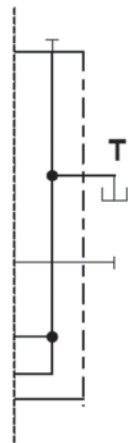

Hydraulic Circuit

Code: GMM M70-2P / SMR2-120 / 1A-SR-STL/1A-SR-STL/CT-PA1/SGT

INSTALLATION AND MAINTENANCE

The GMM M70 valve is assembled and tested as per the technical specification of this catalog. Before the final installation on your equipment, follow the below recommendation:

- The valve can be assembled in any position, in order to prevent body deformation and spool sticking mount the product on a flat surface;
- In order to prevent the possibility of water entering the lever box and spool control kit, do not use high pressure wash down directly on the valve;
- Before painting, ensure plastic port plugs are tightly in place.

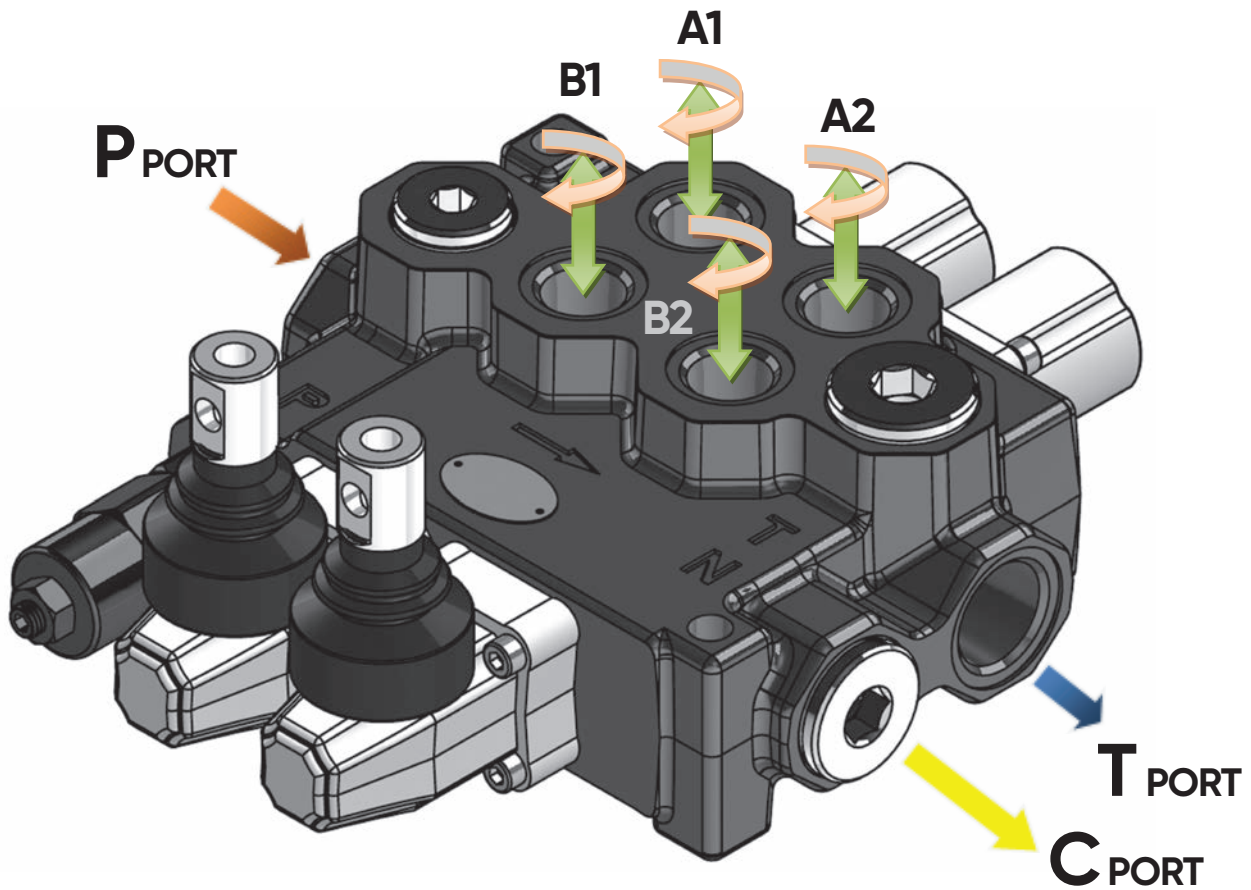

Threads Type (Nm / lbft)	P Port	A and B Port	T and C Port
BSP (ISO 228/1)	G 1/2	G 1/2	G 3/4
With O--Ring seal	50 / 36.9	50 / 36.9	70 / 51.6
With copper washer	60 / 44.3	60 / 44.3	70 / 51.6
With steel and rubber washer	60 / 44.3	60 / 44.3	70 / 51.6
BSP (ISO 228/1)	G 3/4	G 3/4	G 3/4
With O--Ring seal	70 / 51.6	70 / 51.6	70 / 51.6
With copper washer	70 / 51.6	70 / 51.6	70 / 51.6
With steel and rubber washer	70 / 51.6	70 / 51.6	70 / 51.6
UN--UNF (ISO 11926--1)	11/16--12 UNF--2B	9/16--18 UNF--2B	11/16--12 UNF--2B
With O--Ring seal	95 / 70	30 / 22.1	95 / 70
METRIC (ISO 262)	M27 x 2	M22 x 1.5	M27 x 2
With O--Ring seal	100 / 73.8	50 / 36.9	100 / 73.8
With copper washer	100 / 73.8	60 / 44.3	100 / 73.8
With steel and rubber washer	100 / 73.8	60 / 44.3	100 / 73.8

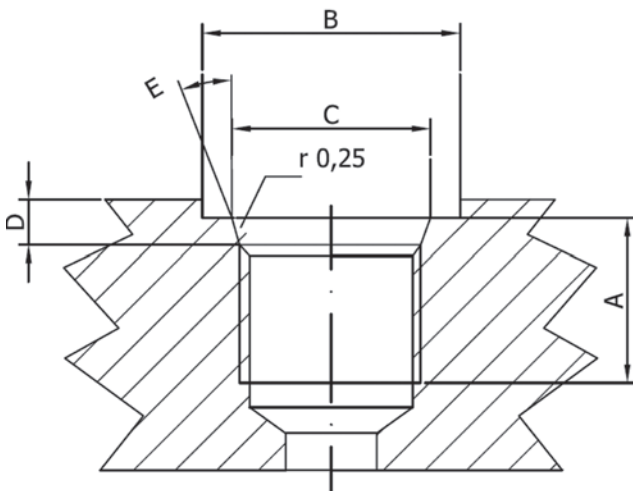
TECHNICAL DATA
Ports Dimensional Data

SAE UN-UNF (ISO 725)							
Dimensions		7/8-14 UNF SAE10		1"1/16-12 UN SAE12		1"5/16-12 UN SAE16	
mm	in						
A		17	0,67	20	0,79	20	0,79
B		34	1,34	41	1,61	49	1,92
C		23,9	0,94	29,2	1,15	35,5	1,40
D		2,5	0,10	3,3	0,13	3,3	0,13
E		15°		15°		15°	

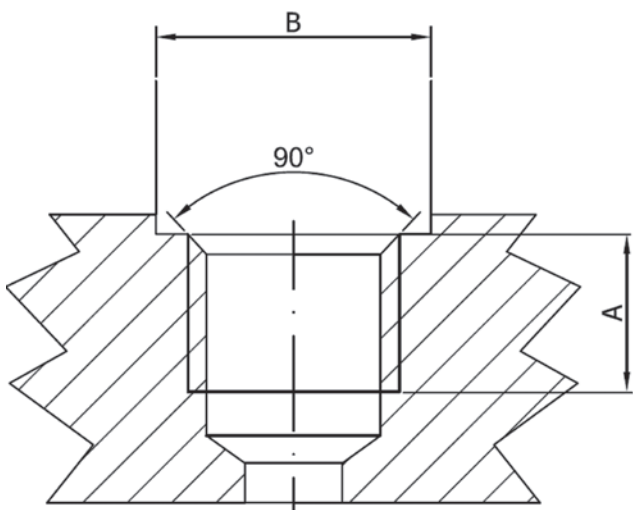

BSP (ISO 228)							
Dimensions		G 1/2"		G 3/4		G1	
mm	in						
A		16	0,63	18	0,71	20	0,79
B		27	1,06	33	1,30	40	1,57

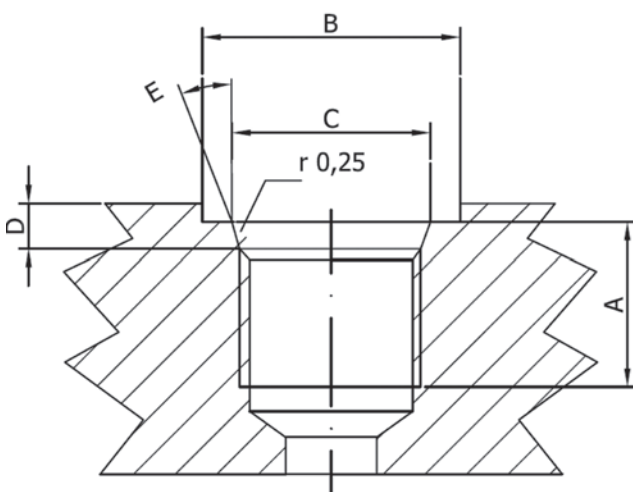

METRIC (ISO 262)							
Dimensions		M22x1,5 ISO 262		M27x2 ISO 262			
mm	in						
A		16	0,63	18	0,71		
B		31,5	1,24	37,7	1,48		