



SECTIONAL
VALVES

GMM-PD120

CE



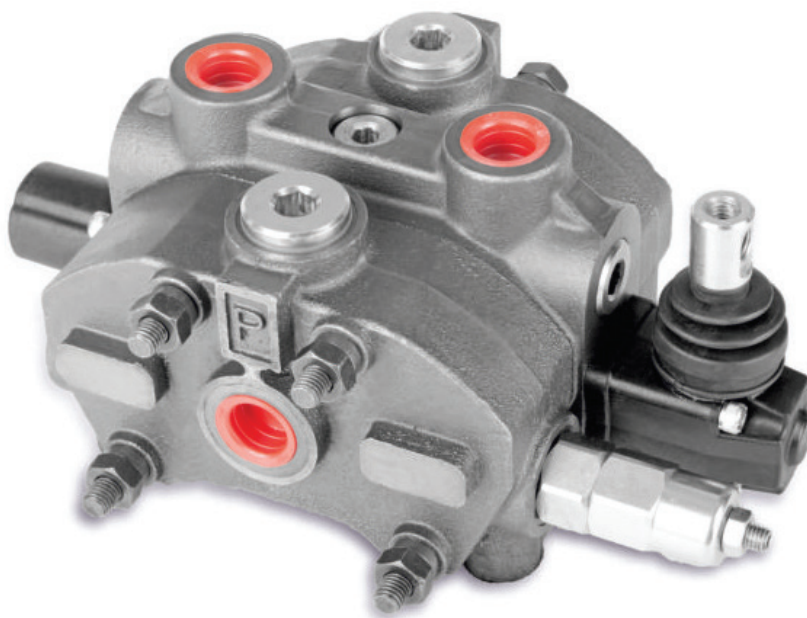

CONTENTS

Working Conditions	265
Dimensional Data	266
Hydraulic Circuit	267
Performance Data And Curve	271
Inlet Relief Options	272
Ordering Codes	274
Inlet Cover- Pump Side	276
Spool Options	278
Spool Positioners – Side of Return	280
Working Section Kit	284
Spool Positioners – Side of Lever Control	285
Spool Positioners – Side of Lever Control	286
Spool Positioners – Side of Lever Control	287
Spool Positioners – Side of Lever Control	288
Outlet Cover- Tank Side	289
Port Valves Options	291
Installation and Maintenance	294
Technical Data	295

Additional Informations

Note: This catalog shows the product in the most standard configurations. For Other Configurations, more detailed information or special request, Please contact Customer Service Dpt.

Warning!: All specifications of this catalog refer to the standard product at this date (01/2020). GEMMA, oriented to a continuous improvement, reserves the right to discontinue, modify or revise the specifications, without notice.

GEMMA IS NOT RESPONSIBLE FOR ANY DAMAGE CAUSED BY AN INCORRECT USE OF THE PRODUCT.

WORKING CONDITIONS

Nominal Flow Rating / Displacement	120 l/min	31 U.S.G.P.M
Maximum Working Pressure (Series Circuit)	210 Bar	3050 PSI
Maximum Working Pressure (Parallel Circuit)	315 Bar	4600 PSI
Max. Back Pressure	25 Bar	360 PSI
Oil Temperature with NBR Seals	-20 to 80 C°	-4 to 176 F°
with FPM (Viton) Seals	-20 to 100 C°	-4 to 212 F°
Oil Viscosity – Operating Range	From 15 to 75 mm ² /s	From 15 to 75 cSt
Minimum / Maximum	12 / 400 mm ² /s	12 / 400 cSt
Oil Filtration	≤30 μ	
Ambiant Temperature Range	-35 to 60 C°	-31 to 140 F°
Number Of Spools	1 to 12	
Internal Leakage (at 100 bar (1450 PSI), 40C° (110 F°), 46 cSt – A(B)–T)	4 cm ³ /min	0,24 in ³ /min
Max. Level Of Contamination	19/16 - ISO 4406	
Tie rod tightening torque	40 Nm	30 lbft

Not: This catalogue shows technical specifications measured with mineral oil of 46 mm²/s-46 cSt viscosity at 40 C° temperature.

Features

- Simple, compact and heavy duty designed sectional valves from 1 to 12 sections for open and closed center hydraulic systems.
- Optional Carry-Over port only tandem circuit.
- Fitted with a main pressure relief valve.
- Interchangeable spool diameter is 20 mm – 0,79 in.
- Available manual, pneumatic, hydraulic and electro-pneumatic spool control kits.

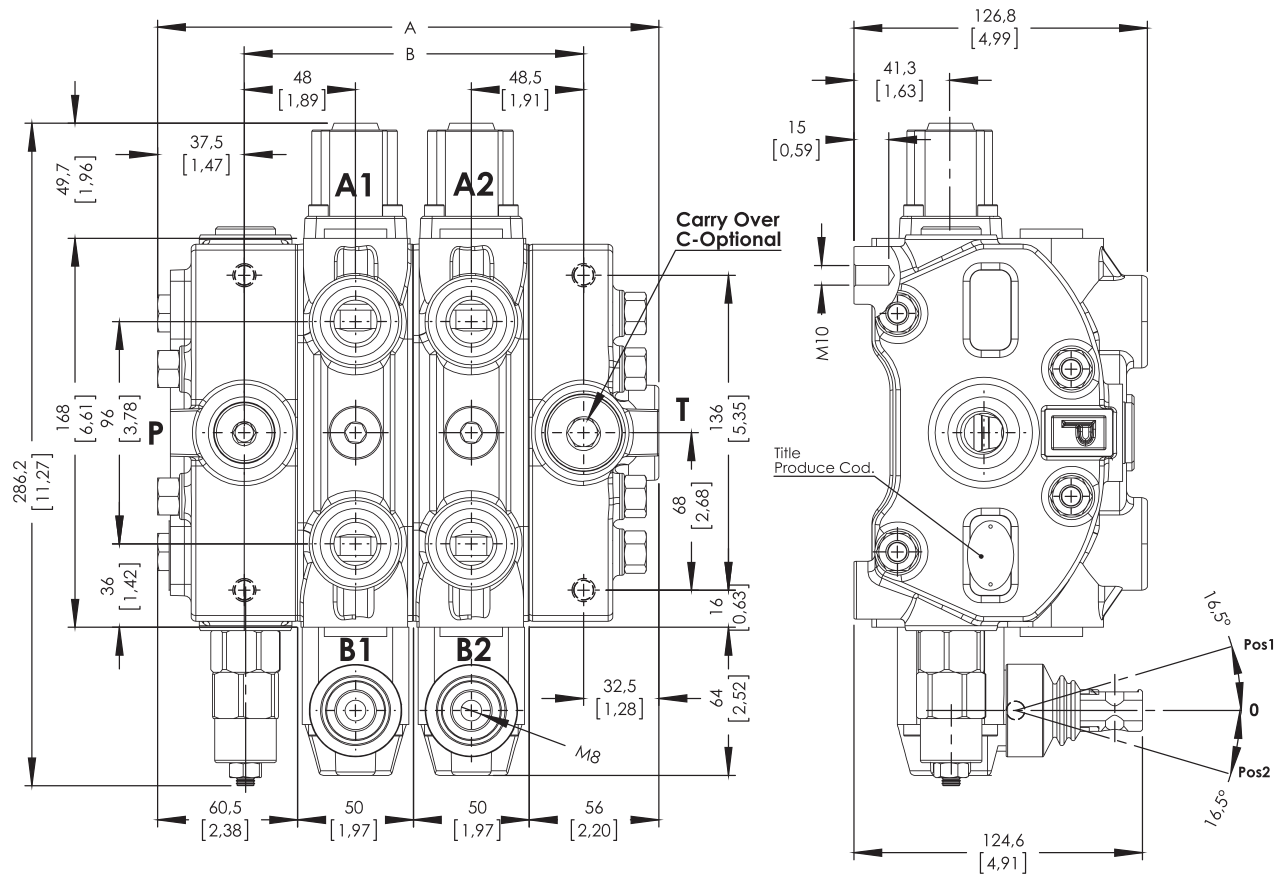
DIMENSIONAL DATA

TYPE	A		B		Weight	
	mm	in	mm	in	Kg	lb
GMM- PD120-1P	216,5	8,52	146,5	5,77	13.70	29.67
GMM- PD120-2P	266,5	10,49	196,5	7,74	19.18	43.21
GMM- PD120-3P	316,5	12,46	246,5	9,71	24.70	56.75
GMM- PD120-4P	366,5	14,43	296,5	11,68	30.30	70.29
GMM- PD120-5P	416,5	16,40	346,5	13,65	35.82	83.83
GMM- PD120-6P	466,5	18,37	396,5	15,62	41.80	97.37
GMM- PD120-7P	516,5	20,34	446,5	17,59	46.97	110.91
GMM- PD120-8P	566,5	22,31	496,5	19,56	52.60	124.45
GMM- PD120-9P	616,5	24,28	546,5	21,53	58.00	137.99
GMM- PD120-10P	666,5	26,25	596,5	23,50	63.56	151.53
GMM- PD120-11P	716,5	28,22	646,5	24,57	69.00	165.07
GMM- PD120-12P	766,5	30,19	696,5	27,44	74.50	178.61

STANDARD THREADS

PORT	BSP (Iso 228)		UN-UNF (Iso 11926-1)	Metric (Iso 262)
	1/2" Series	3/4" Series		
P Inlet	G 1/2	G 3/4	11/16-12 UN	M27x2
A-B Ports	G 1/2	G 3/4	7/8-14 UNF	M22x1.5
T Outlet	G 3/4	G 3/4	11/16-12 UN	M27x2
Pneumatic	G 1/4	G 1/4	NPTF 1/8 - 27	NPTF 1/8 - 27
Carry-Over	G 3/8	G 3/8	3/4-16 UNF	G 3/8

HYDRAULIC CIRCUIT

Parallel

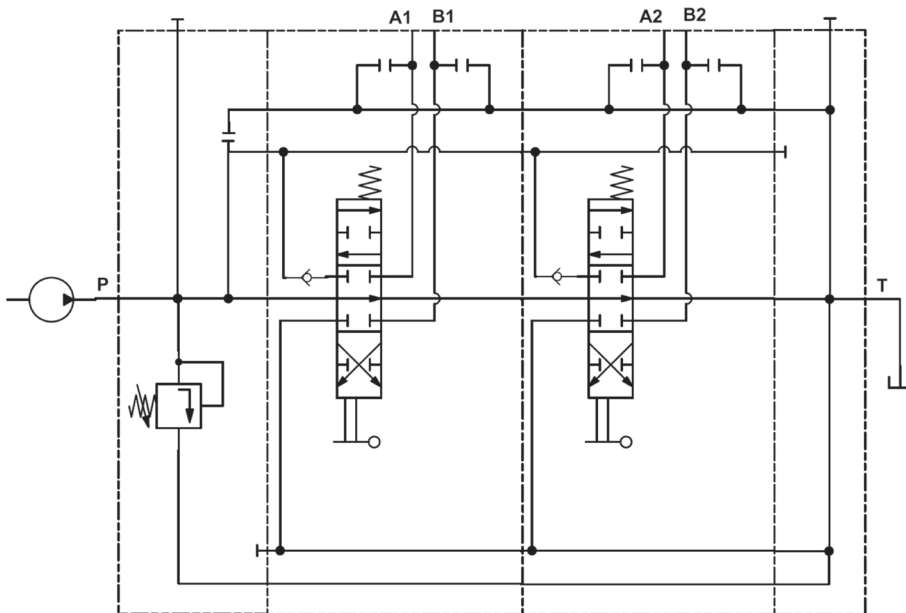
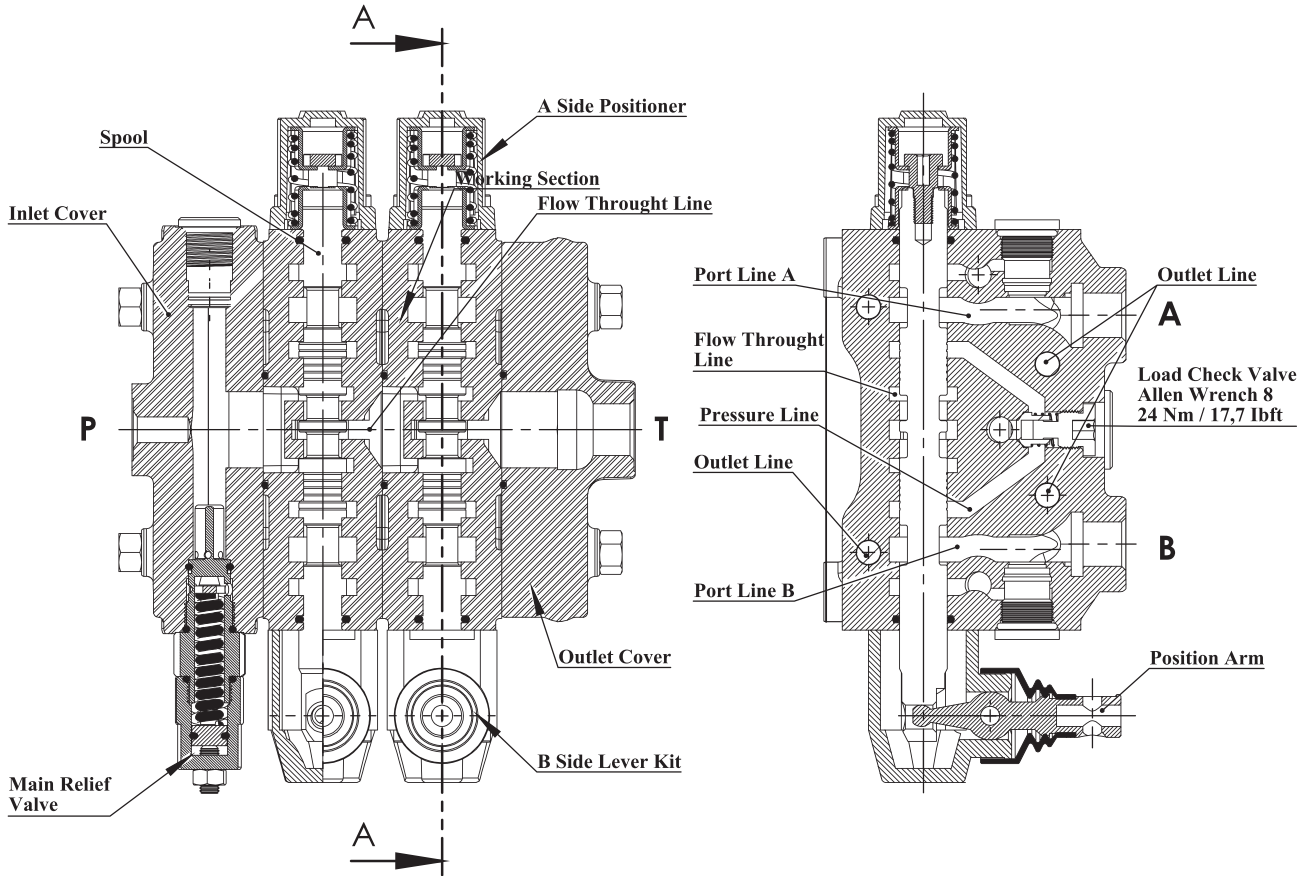

Code: GMM PD120-2P (SD(LA)-SMR2-125-PP)/P-1A-STL-SR/ P-1A-STL-SR/ SO-PT1 / SGT

HYDRAULIC CIRCUIT

Inlet Cover – Pump Side

SD - Side inlet with direct pressure relief valve
 TD - Top inlet with direct pressure relief valve
 SP - Side inlet with relief valve blanking plug

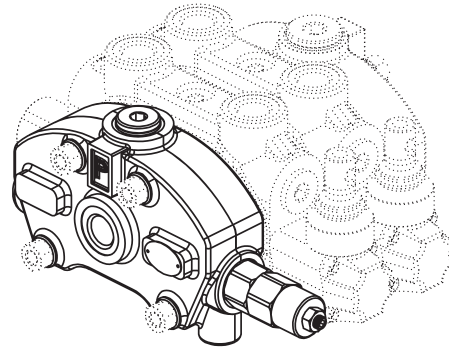

Type = SD

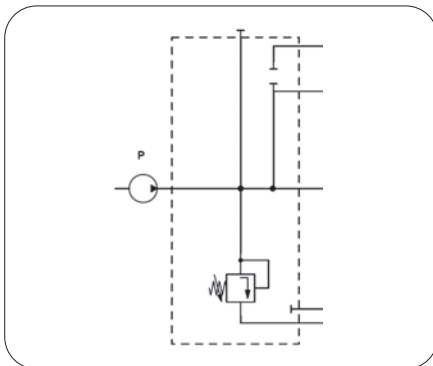

Type = TD

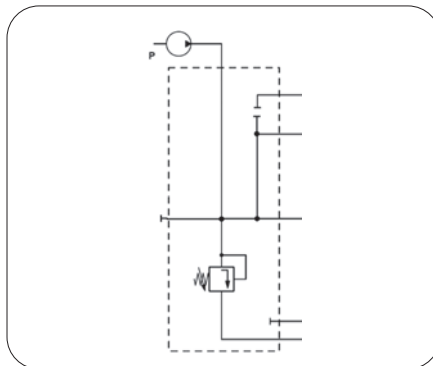

Type = SP

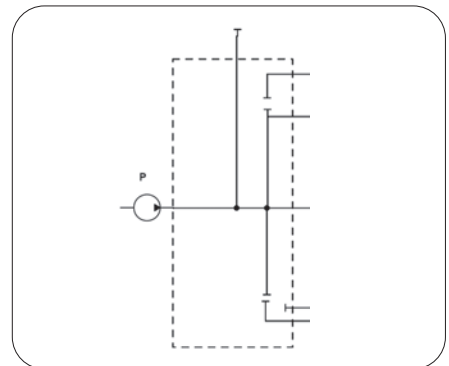

Working Sections

P – Parallel

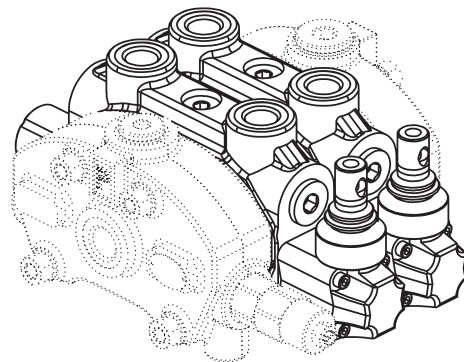

Type = P

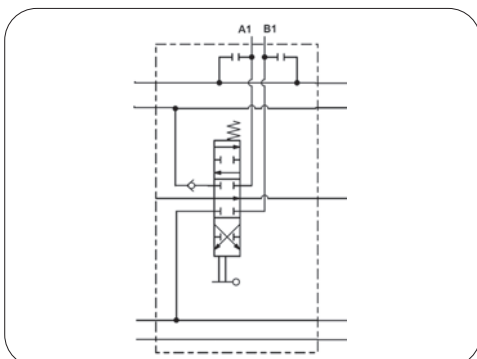

HYDRAULIC CIRCUIT

Outlet Cover (Tank Side)

- SO - Side outlet
- TO - Top outlet
- TCO - Top outlet with carry-over
- TC - Top outlet with closed centre

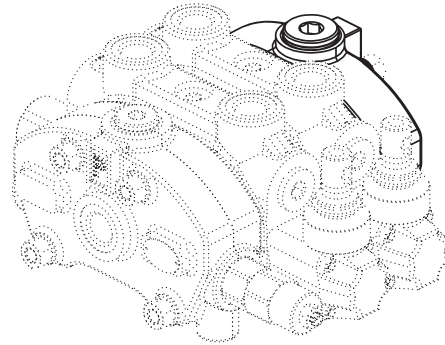

Type = SO

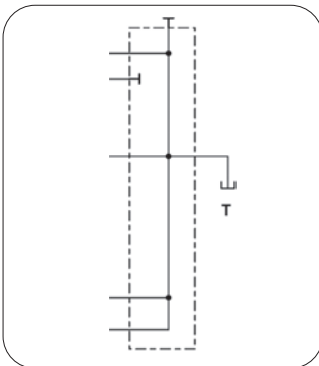

Type = TO

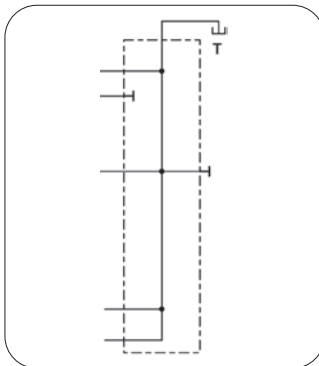

Type = TCO

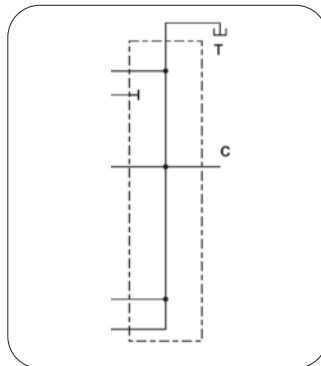

Type = TC

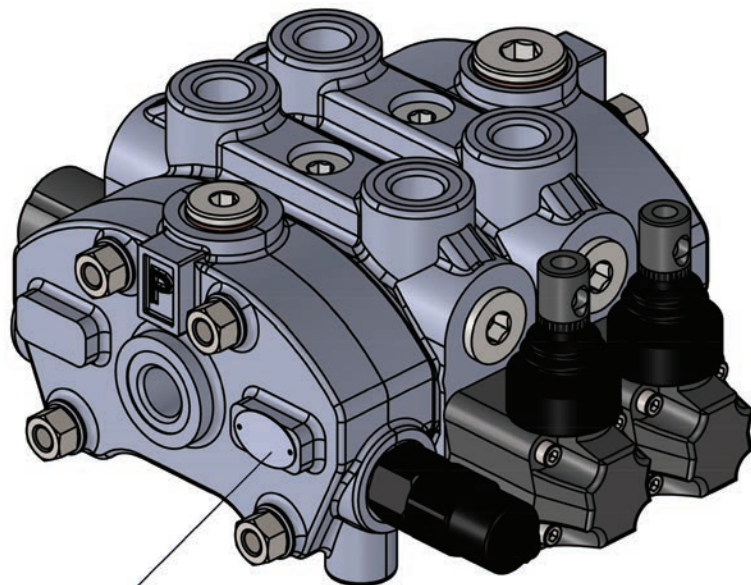
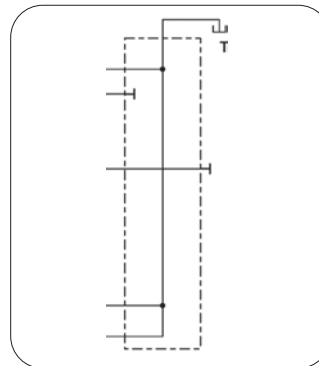

Valve Type

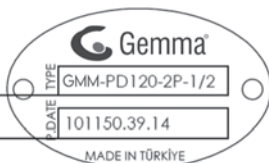

Production Batch
39.14 = Production Year - Week (2014/39)
101150 = Progressive Party Number

HYDRAULIC CIRCUIT
Standard Configurations With Top Inlet And Outlet Ports - RH (Right Inlet)

A symmetrical body allows the reverse assembly of spool.

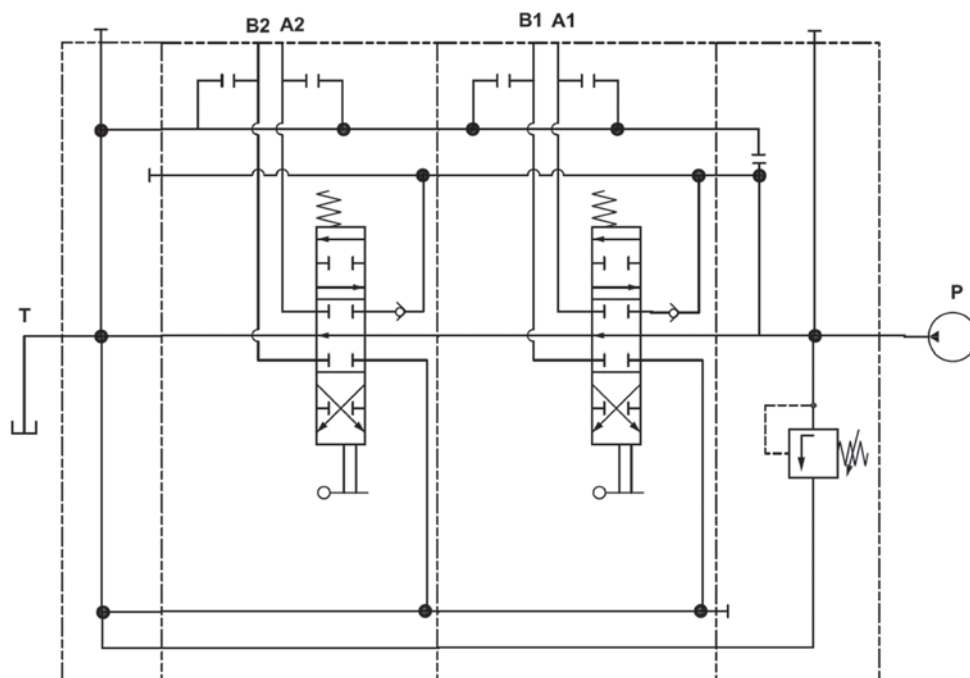
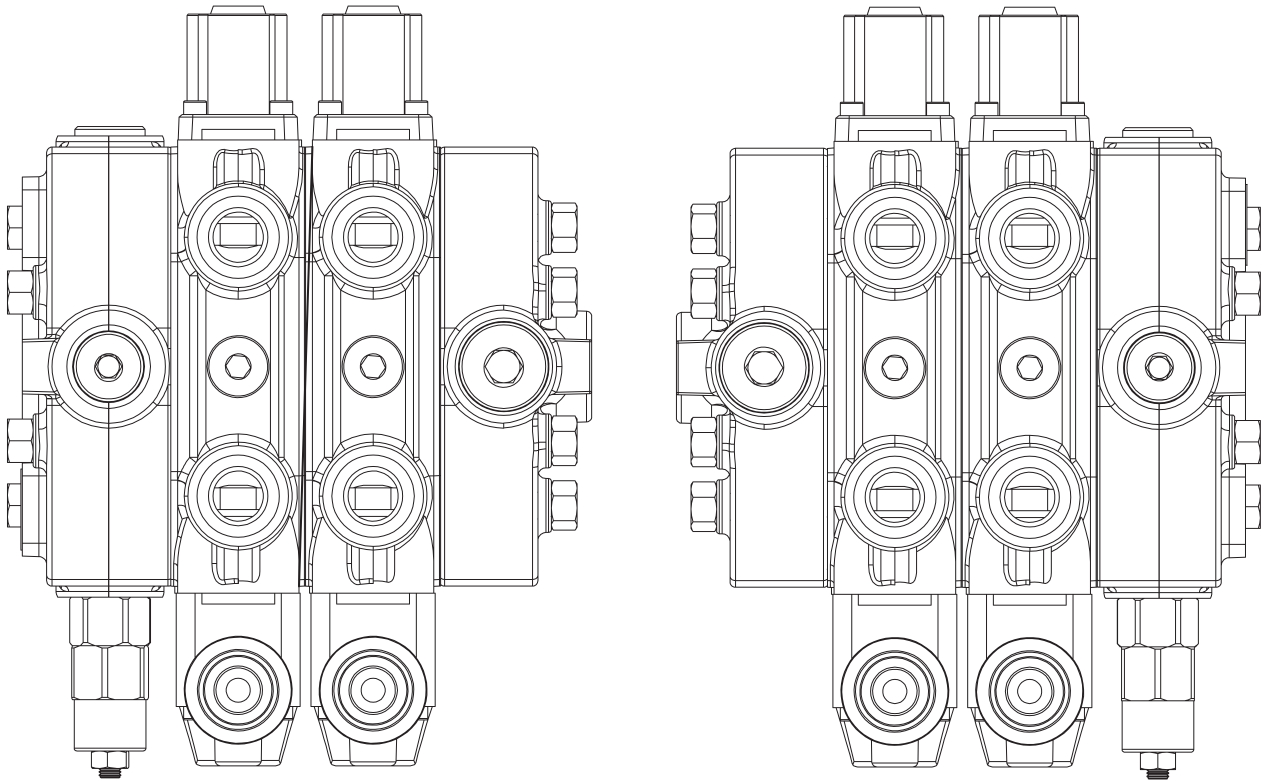

Code: GMM PD120-2P (SD(RA)-SMR2-125-PP)/P-1A-STL-SR/ P-1A-STL-SR/ SO-PT1 /

PERFORMANCE DATA AND CURVE

Open Center - Pressure Drop (P-T)

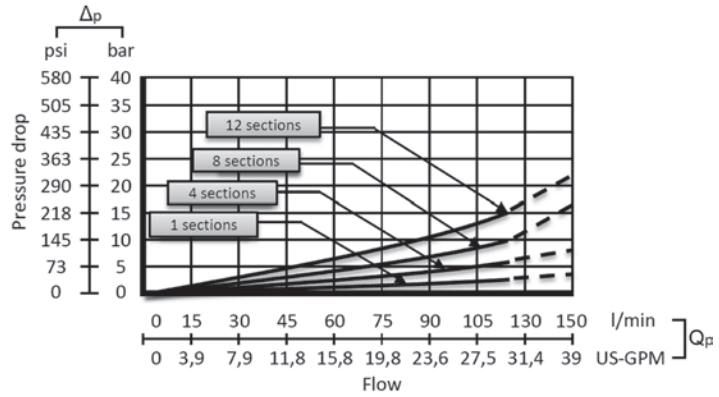
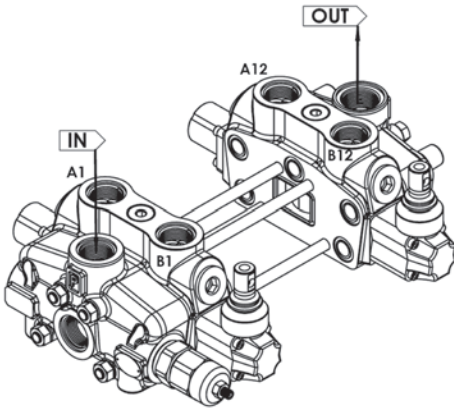

Inlet to Work Port - Pressure Drop (P-A/B)

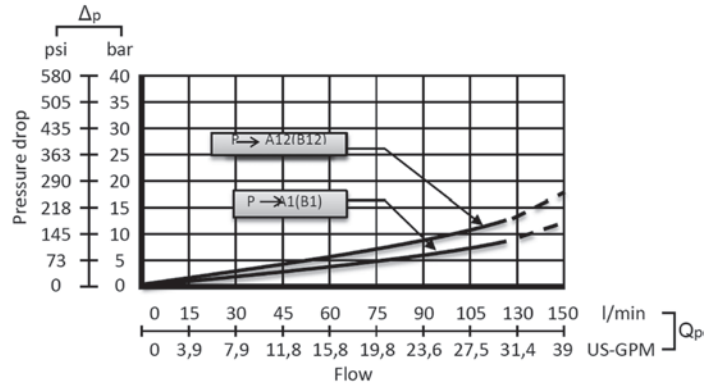
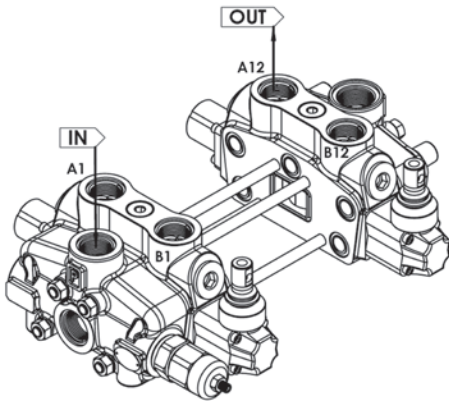

Work Port to Outlet - Pressure Drop (A/B-T)

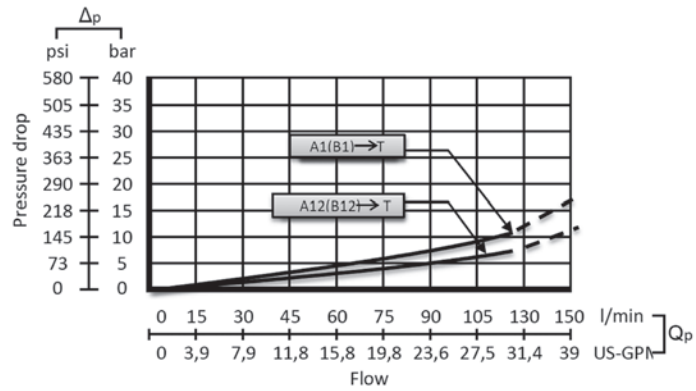
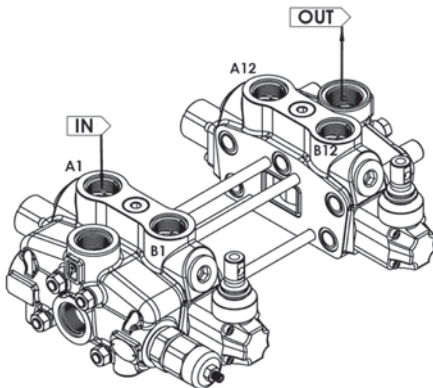

INLET RELIEF OPTIONS

Direct Pressure Relief Valve

Code:

SMR2 – 125

- Pressure Setting Bar in (Standard 125 bar)
- Standard Main Relief Spring Type -2

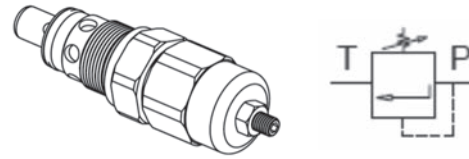

Performance Data

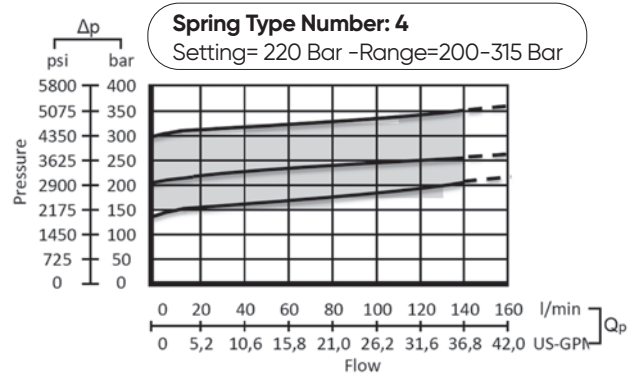
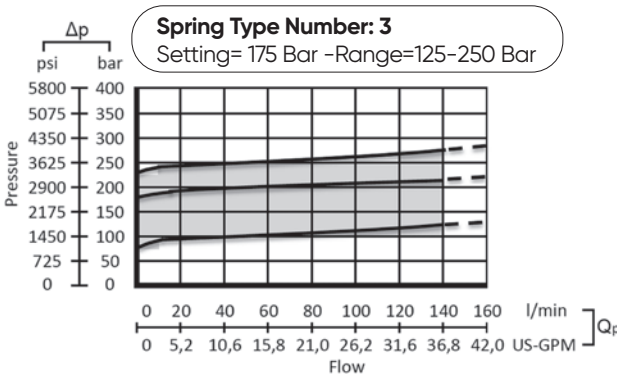
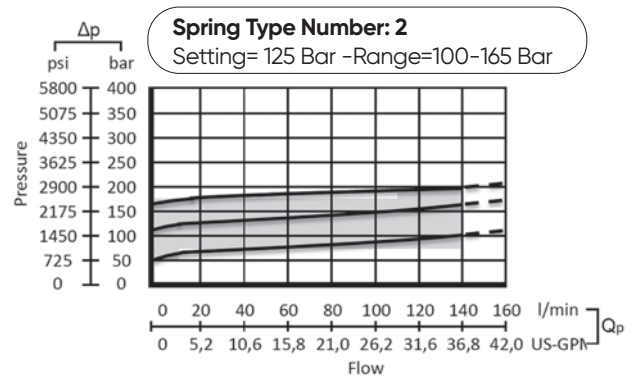
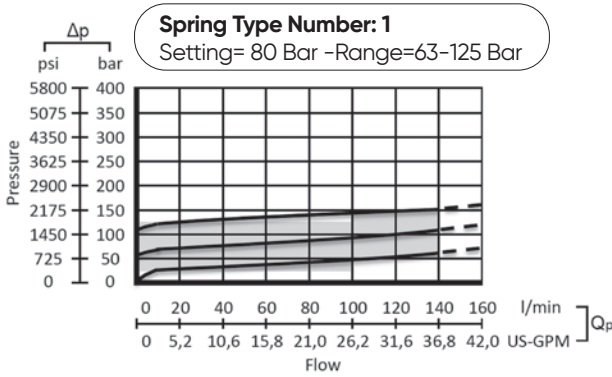

Adjustment Type on Valve

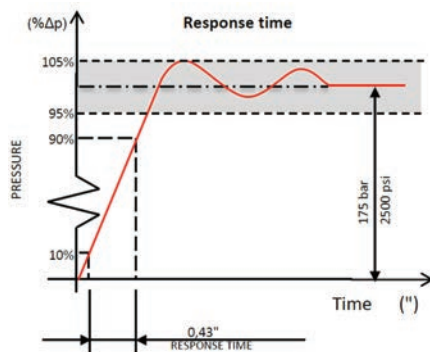
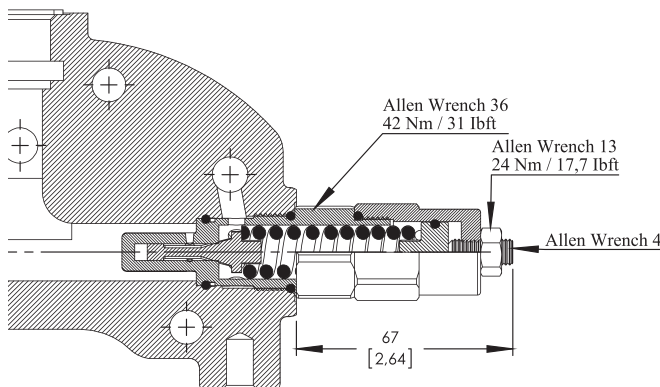

INLET RELIEF OPTIONS

Direct Pressure Relief Valve

Kit No: **PAC**

Sectional Appearance

Diagram

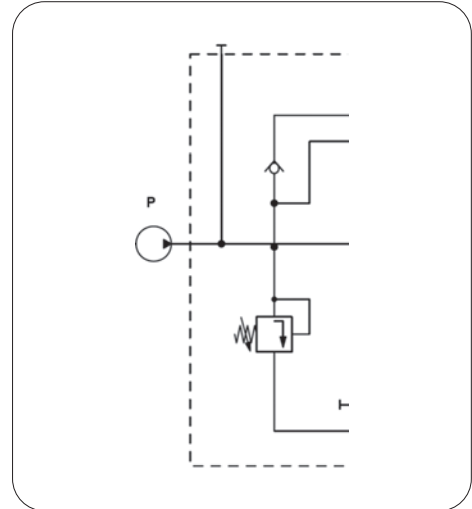
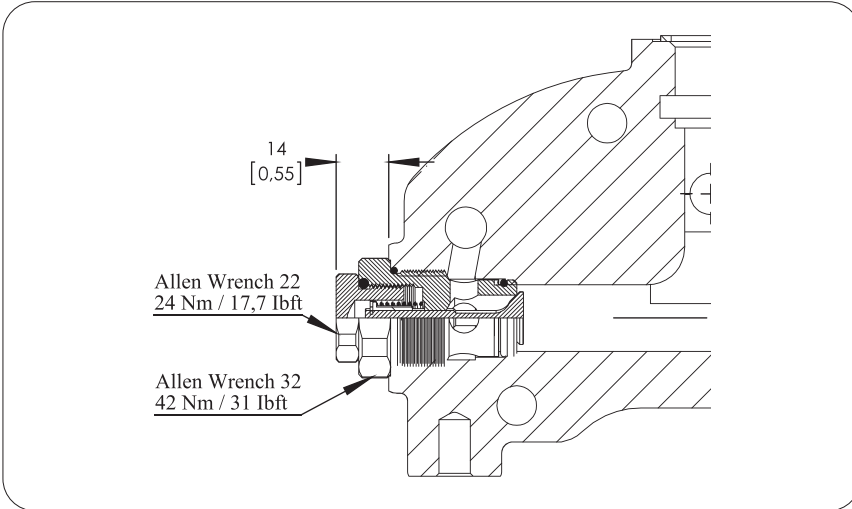

Performance Data

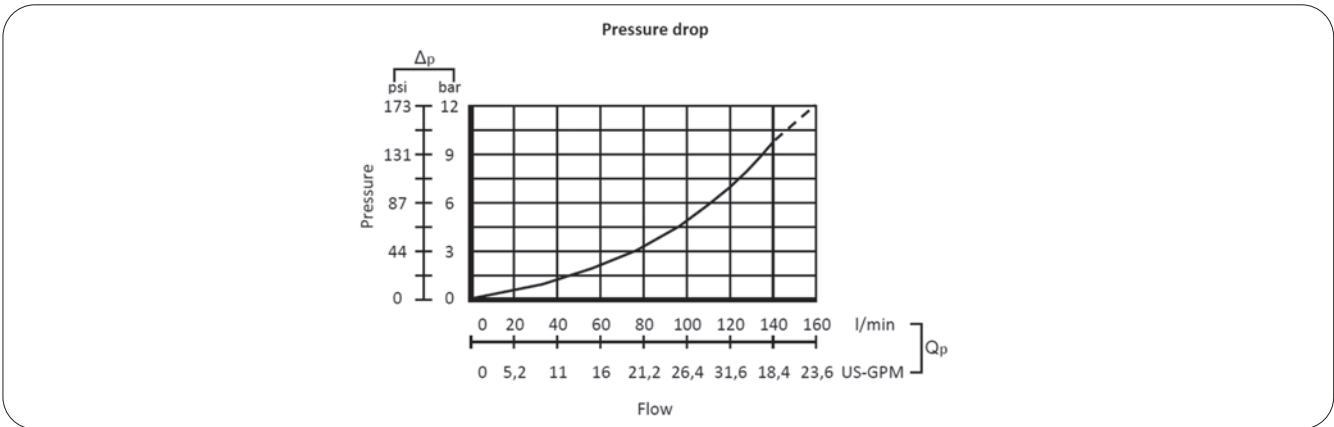

Relief Blanking Plug - SP

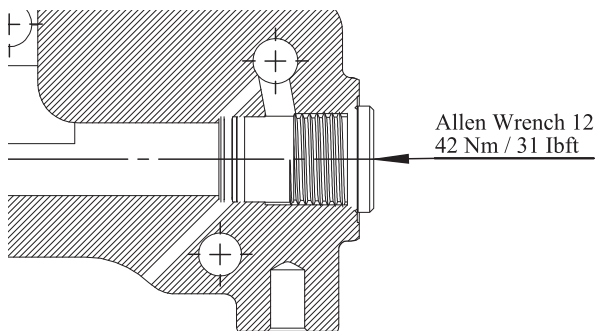

ORDERING CODES

Order Example

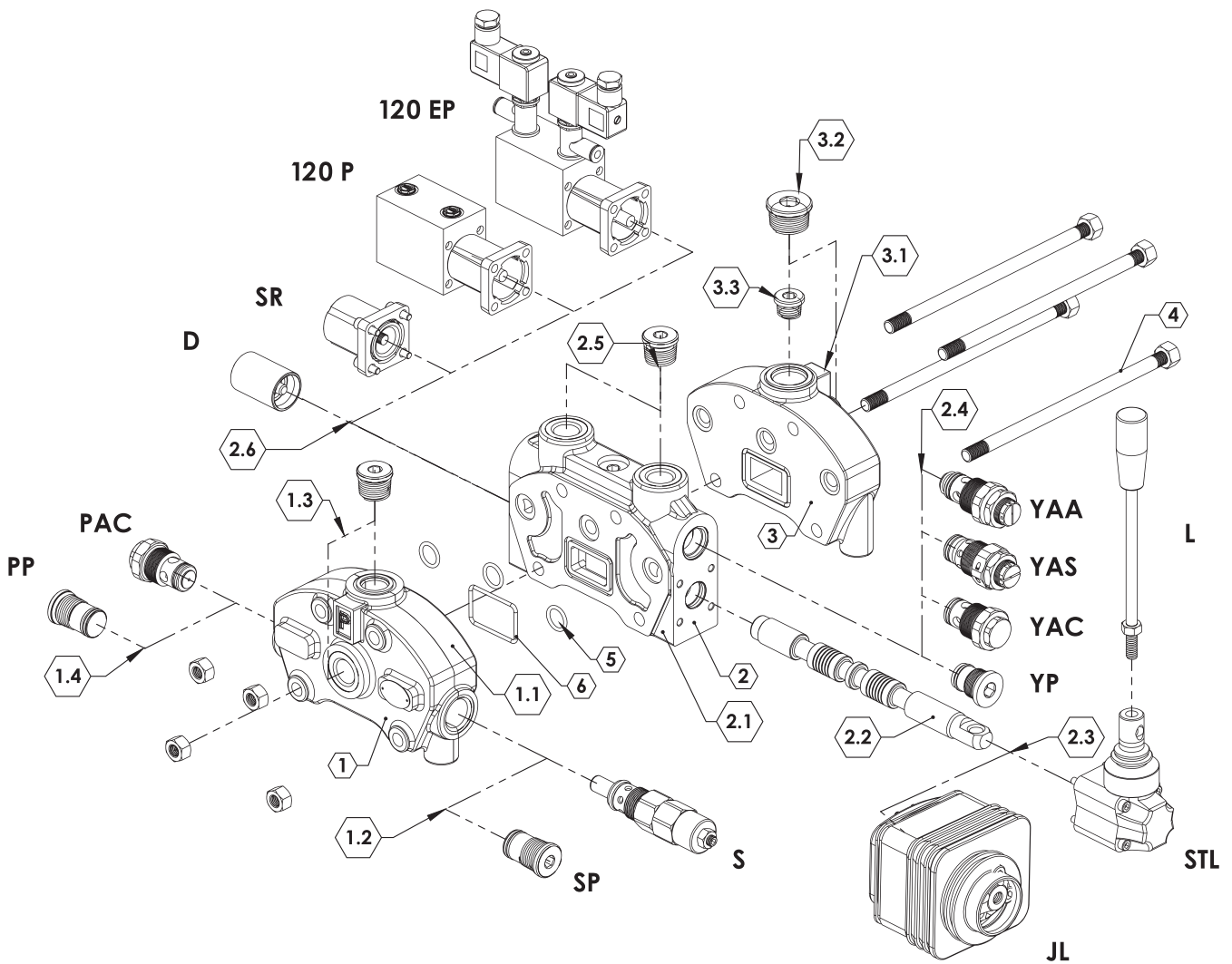
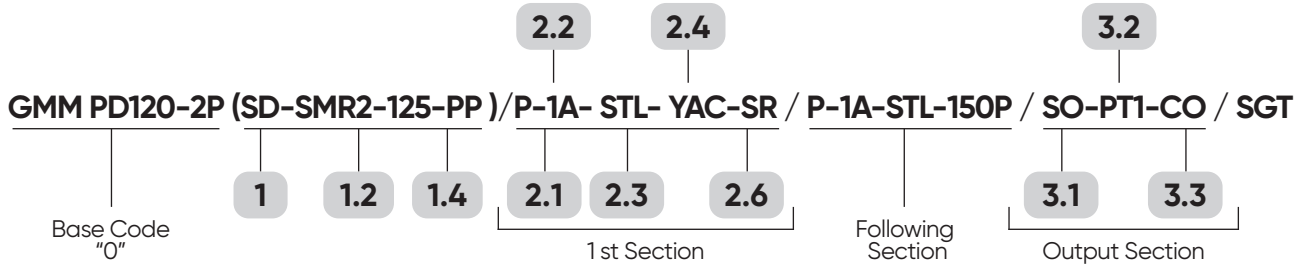

ORDERING CODES

1- Inlet Section

GMM PD120-2P PD120 = Valve Type-(PD)- Sectional (120) - Max. Flow Rate
 2P =Sections Quantity
 SD = Side inlet with direct pressure relief valve (1SD120100)
 TD = Top inlet with direct pressure relief valve (1TD120100)
 SP = Side inlet with relief valve blanking plug (1SP120100)

2- Working Section

P = Parallel (2P120100)

3- Output Section

SO = Side outlet (3SO120100)
TO = Top outlet (3TO120100)
TCO = Top outlet with carry-over (3TCO120100)
TC = Top outlet with closed centre (3TC120100)

4- Assembling Kit

Tie rod kit for 1 section valve - (4TRK1120100)
 Tie rod kit for 2 section valve - (4TRK2120100)
 Tie rod kit for 3 section valve - (4TRK3120100)
 Tie rod kit for 4 section valve - (4TRK4120100)
 Tie rod kit for 5 section valve - (4TRK5120100)
 Tie rod kit for 6 section valve - (4TRK6120100)
 Tie rod kit for 7 section valve - (4TRK7120100)
 Tie rod kit for 8 section valve - (4TRK8120100)
 Tie rod kit for 9 section valve - (4TRK9120100)
 Tie rod kit for 10 section valve - (4TRK10120100)
 Tie rod kit for 11 section valve - (4TRK11120100)
 Tie rod kit for 12 section valve - (4TRK12120100)

5-6- O_Ring Kit

5. -17.00x2.65 NBR 70 SH O-Ring seal (3 Qty.) (5MK150100)
6. -34.60x2.62 NBR 70 SH O-Ring seal (1 Qty.) (6MK150100)

1.*-Inlet Options

1.1 Inlet Cover
Body = Standard (11BS120100)
1.2 Inlet Relief
SMR1-080 - (12SMR1150080)-Range 63-125 bar
 Setting 80 bar
SMR2-125 - (12SMR2150120)- Range 100-160 bar
 Setting 125 bar
SMR3-175 - (12SMR3150175)- Range 125-250 bar
 Setting 175 bar
SMR4-220 - (12SMR4150220)-Range 200-315 bar
 Setting 220 bar
1.3 Ports Plug
PA1 = G1/2 Top and side input - (13PA1800100)
PA2= G3/4 Top and side input - (13PA2800100)
1.4 Inlet Valve
PAC =Inlet anti-cavitation valve - (14PAC150100)
PP(SP) = Relief valve blanking plug - (14PSP150100)

2.*- Working Options

2.1 Working Section

PA = Without ports valve prearrangement, with parallel circuit - Body (21BSPA120100)

2.2 Spool Options

1A -(22SS120110) - 3 Positions ,Double acting
2A -(22SS120120) - 3 Positions ,Double acting
 A to tank B Blocked
3A -(22SS120130) - 3 Positions ,Double acting
 B to tank A blocked
4A -(22SS120140) - 3 Positions ,Double acting
 A and B tank
5A -(22SS120150) - 3 Positions ,Single acting on
 A (A to tank)
6A -(22SS120160) - 3 Positions ,Single acting on
 B (B to tank)

2.3 Lever Options

L = Standard HandLever (L=120mmxM10) - (7L040100)
JL = Joystick lever for two sections operation (5JL 080100)
STL = Standard Lever - (23STL150100)
HL = Remote Cable Kit - (80HL80100)

2.4 Port Relief Valves

Anti-Shock Valve
YAS (T1-50) - (24YAC150050)-Range 35-70 bar
 Setting 50 bar
YAS (T1-100) - (24YAC150100)-Range 63-220 bar
 Setting 100 bar
YAS (T1-200) - (24YAC150200)-Range 180-350 bar
 Setting 200 bar
Anti-Shock and Anti-Cavitation Valve
YAA (T1-63) - (24YAA150063)-Range 35-70 bar
 Setting 50 bar
YAA (T1-100) - (24YAA150100)-Range 63-220 bar
 Setting 100 bar
YAA (T1-200) - (24YAA150200)-Range 180-350 bar
 Setting 200 bar
YAC - Anti Cavitation- (24YAS150100)
YP- A and B ports valve blanking plug (24YP150100)
DST-A and B ports valve blanking plugs with
 connection to tank-(24DST150100)

2.5 Ports Plug Options

PL1 =Plug for single action spool for 2A-3A, G1/2
 (25PL180100)
PL2 =Plug for single action spool for 2A-3A, G3/4
 (25PL280100)

2.6 Spool Positioners

SR=Spring Return in neutral position - (26SR150100)
D =Detent in position 1, neutral and 2 - (26D150100)
100P=ON/OFF Pneumatic - (2645P150100)
100EP=12 VDC ON/OFF electro-pneumatic
 (26150EP150112)
100EH= 12 VDC/24 VDC ON/OFF electro-hydraulic
 (36150EH100112)

3.*- Working Options

3.1 Working Section

Body = Standard (31BS150100)

3.2 Output Plug

PT1 =G3/4 Top and Side output (32PT180100)

3.3 Circuits Options

CO =G1/8 Carry-Over Connector (33CO150100)

INLET COVER- PUMP SIDE

LH Inlet Valve Options

Type No: SD

Sectional Appearance

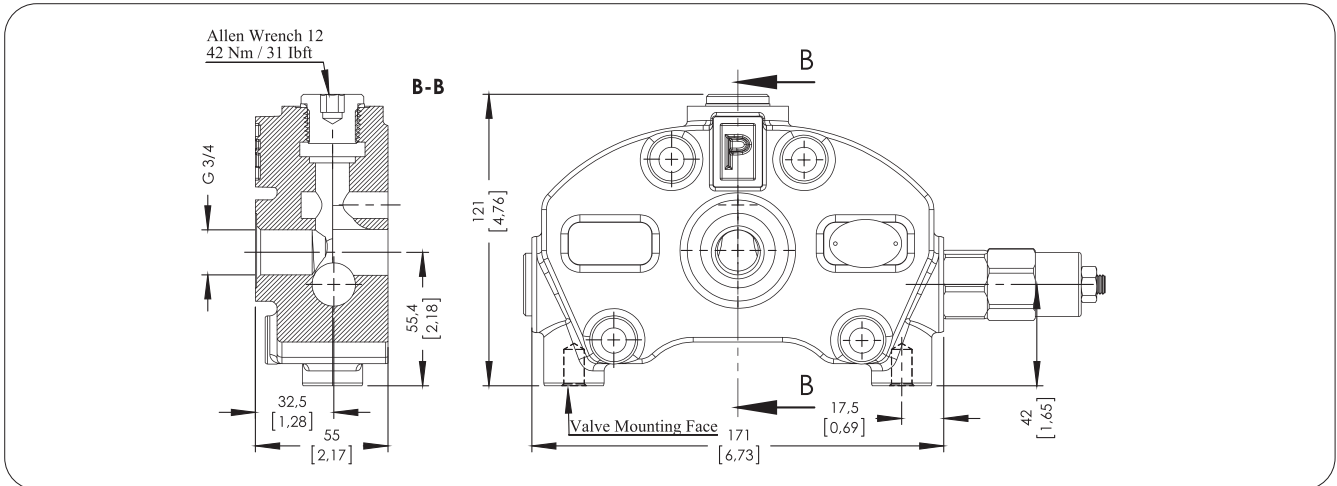

Type No: TD

Sectional Appearance

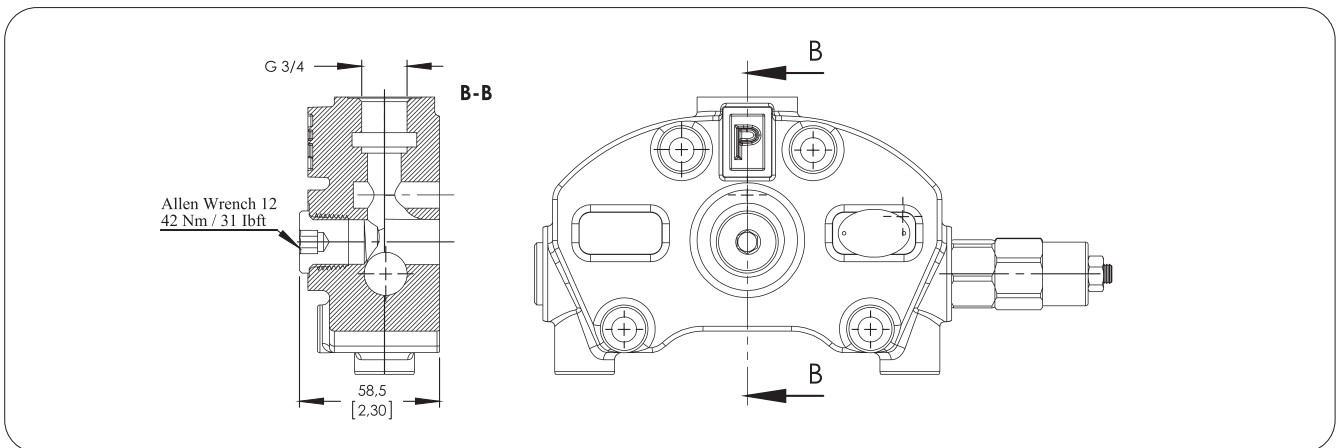

Hydraulic Diagram

Type No: SD

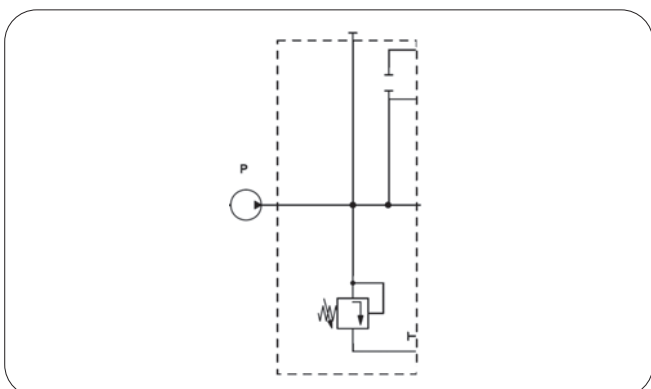

Type No: TD

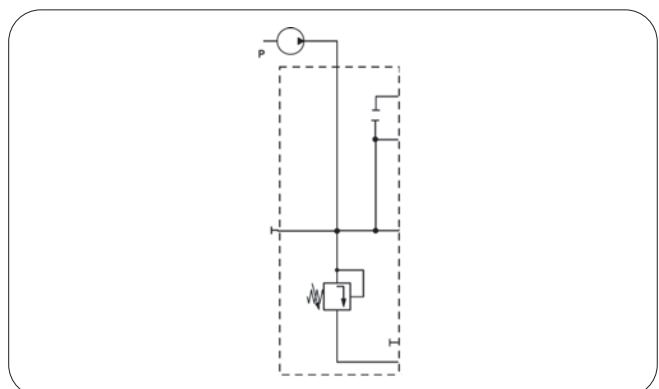

INLET COVER- PUMP SIDE

RH Inlet Valve Options

Type No: **RA**

Sectional Appearance

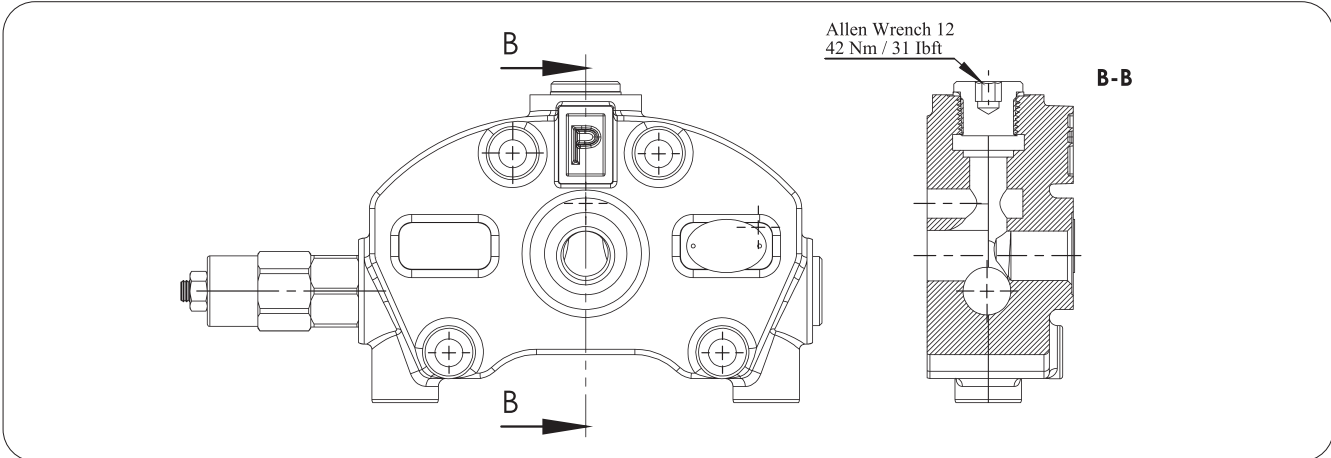

Type No: **RB**

Sectional Appearance

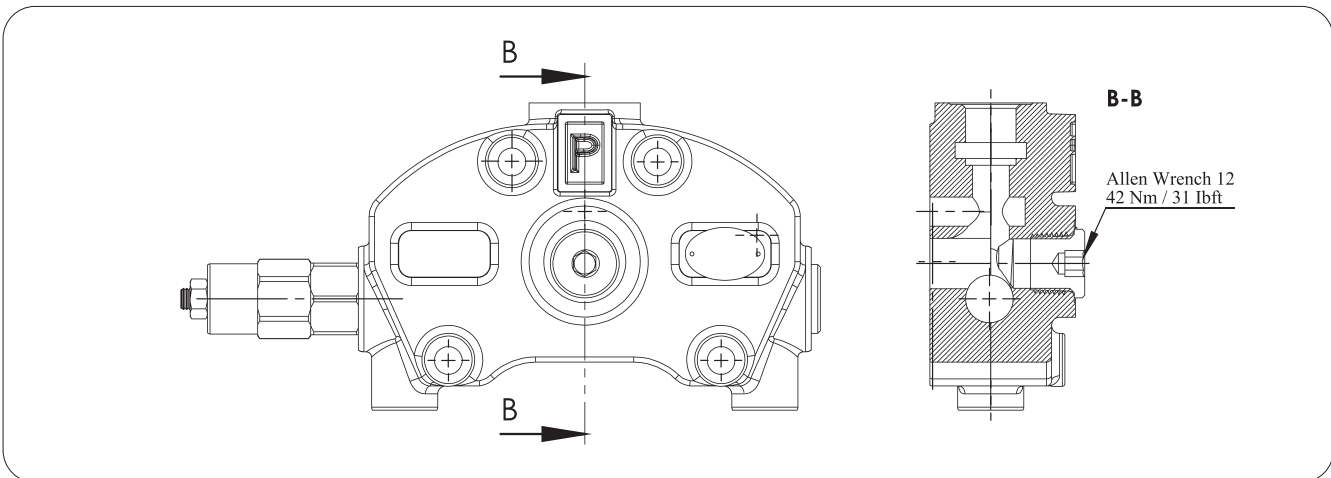

Hydraulic Diagram

Type No: **RA**

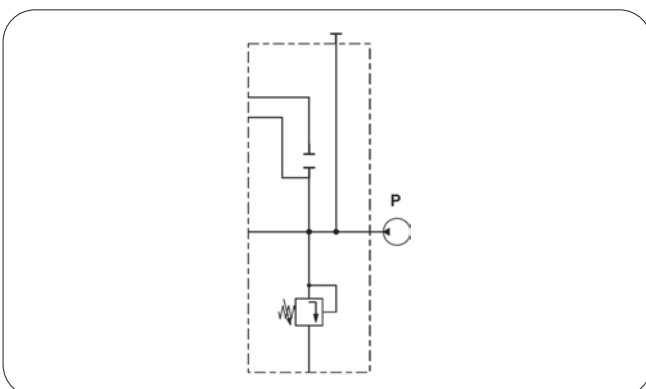

Type No: **RB**

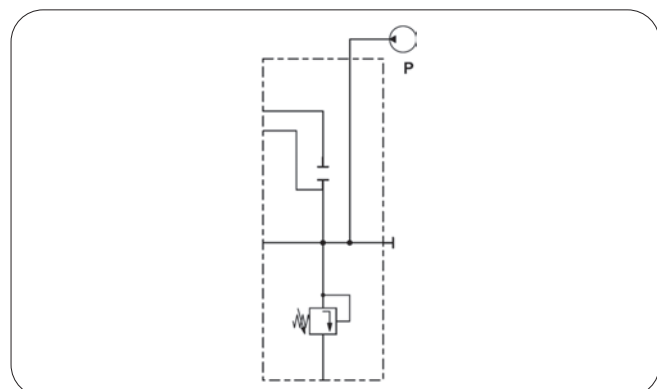

SPOOL OPTIONS

Spool Type - 1A

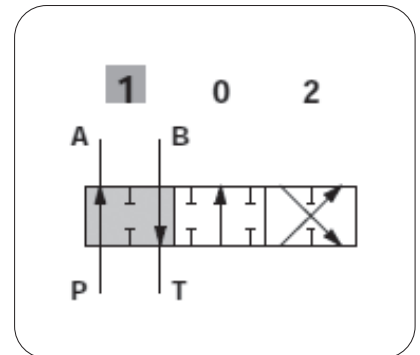
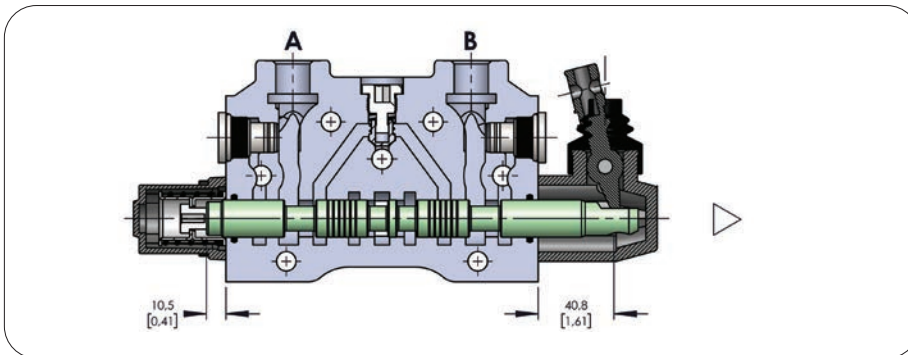
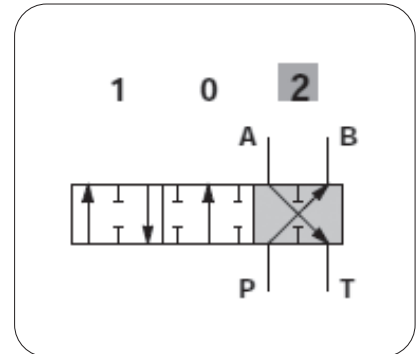
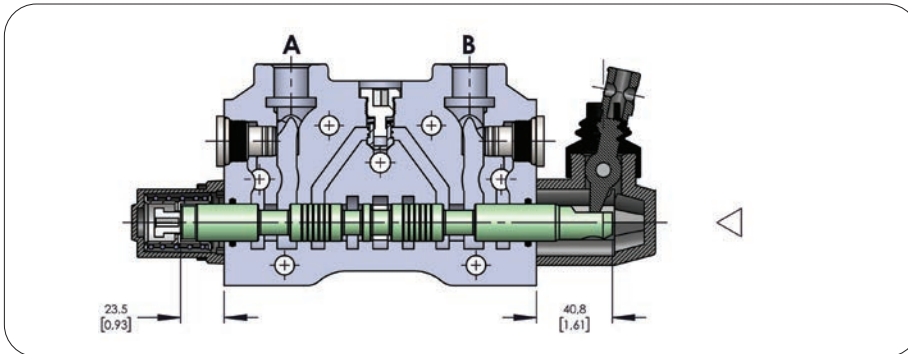
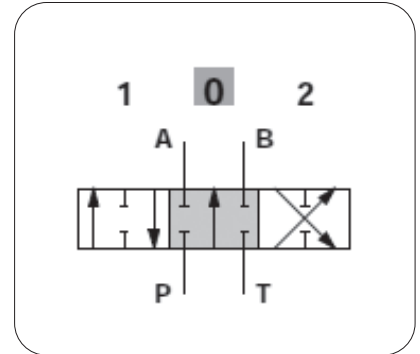
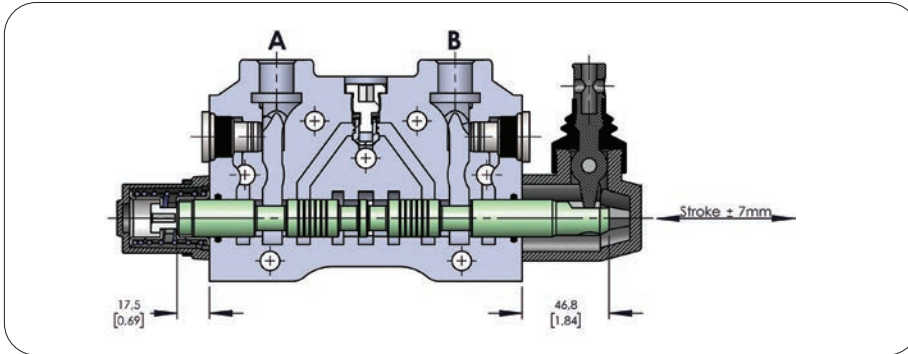

Performance Curve And Data

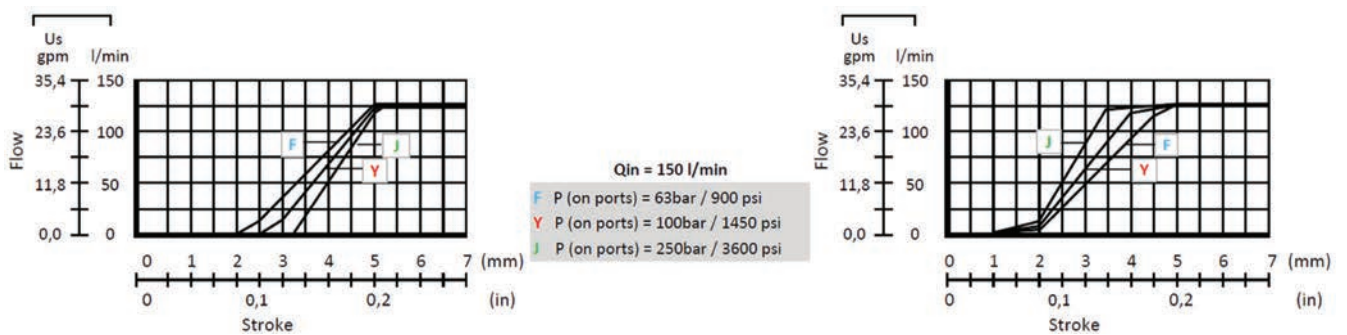

SPOOL OPTIONS

Spool Type - 2A

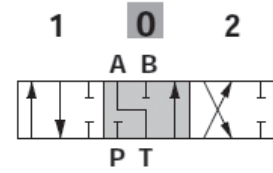
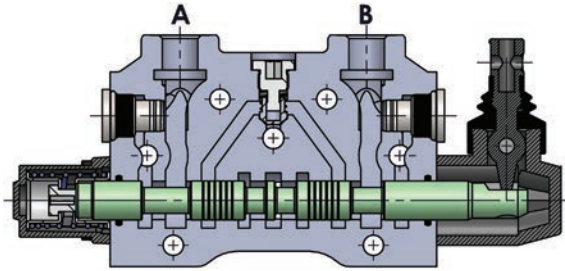

Spool Type - 3A

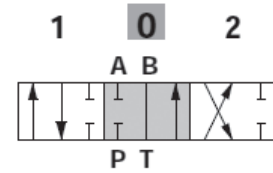
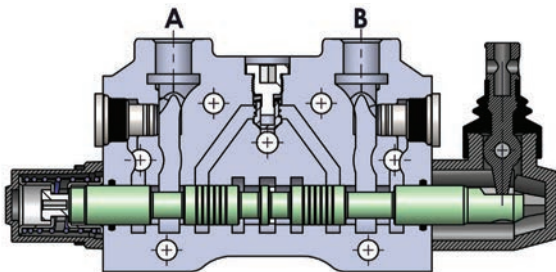

Spool Type - 4A

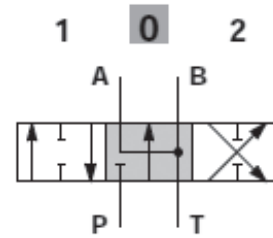
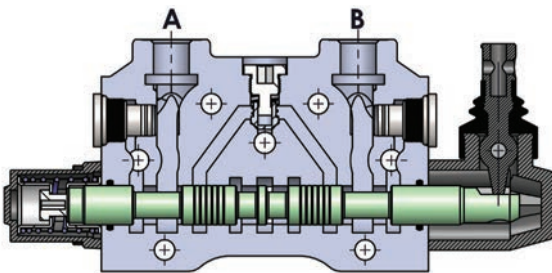

Spool Type - 5A

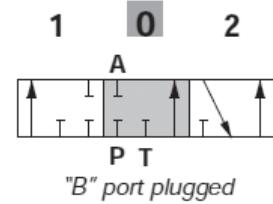
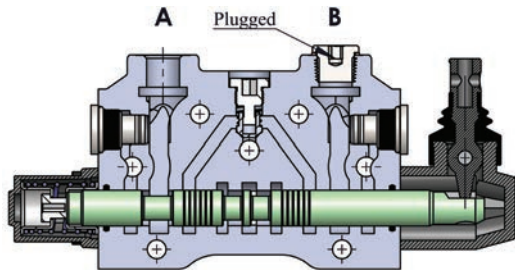

Spool Type - 6A

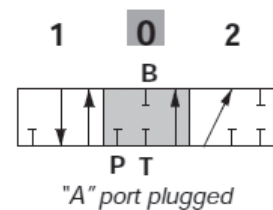
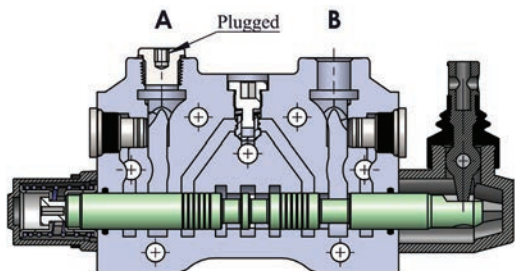

SPOOL POSITIONERS – SIDE OF RETURN

With Spring Return in Neutral Position

Kit No: **SR**

Sectional Appearance

Diagram

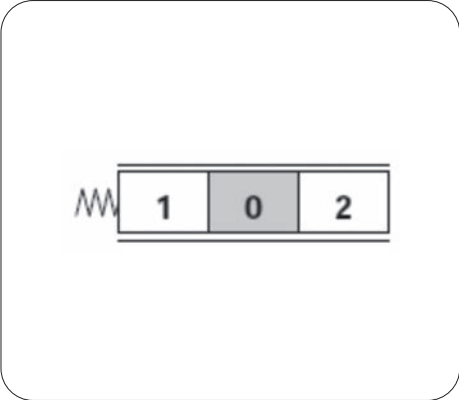
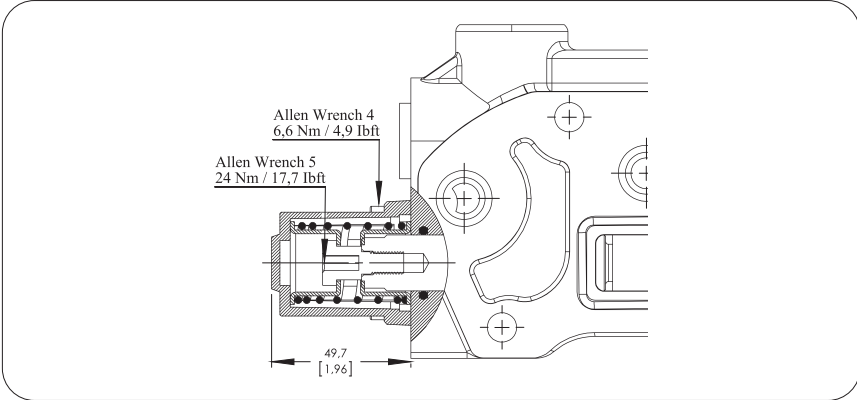

With Detent

Kit No: **D**

Sectional Appearance

Diagram

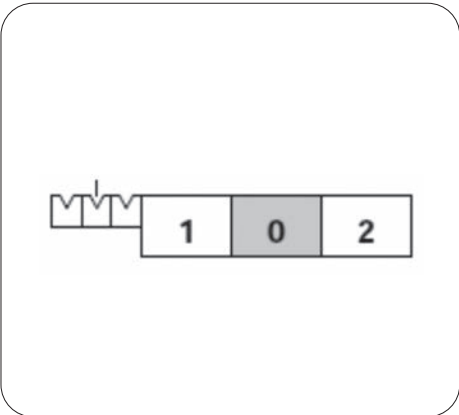
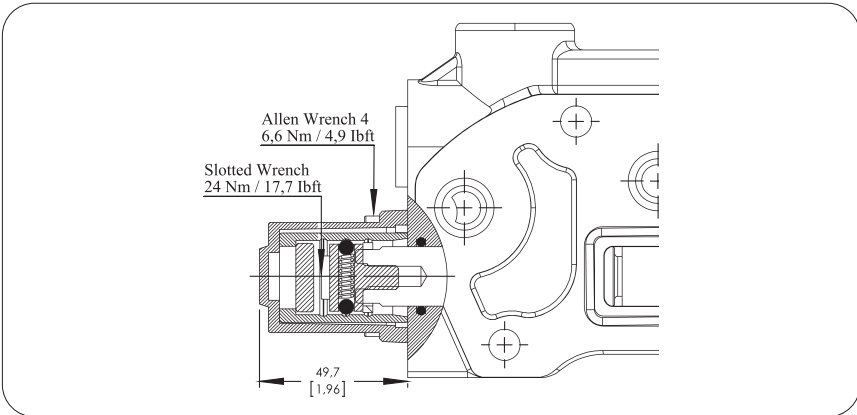

Force - stroke diagram

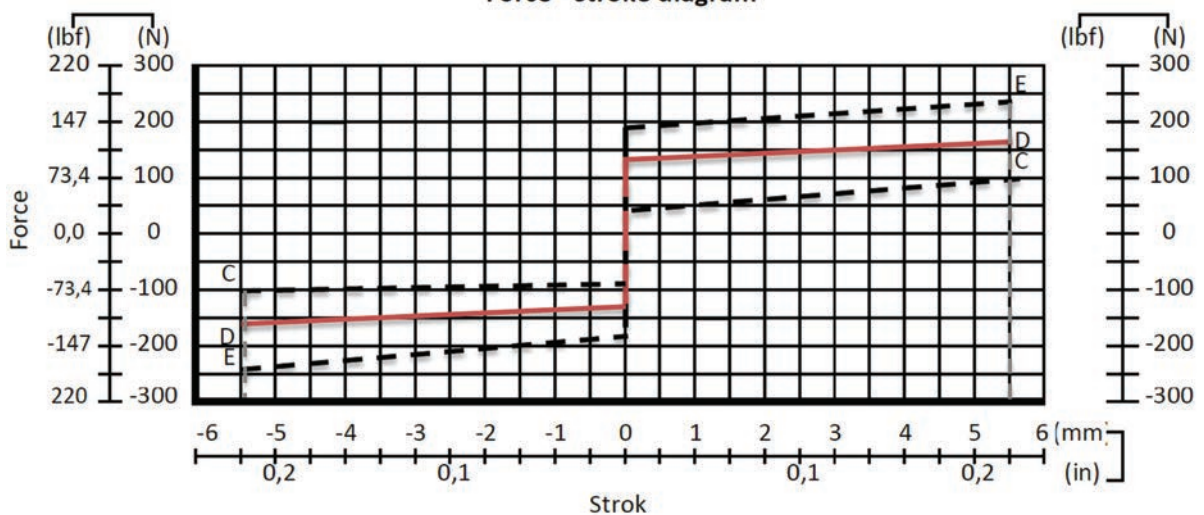

SPOOL POSITIONERS – SIDE OF RETURN

ON/OFF Pneumatic Control

Kit No: **120P**

Sectional Appearance

Diagram

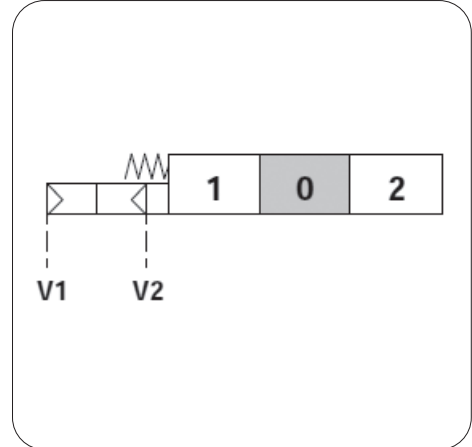
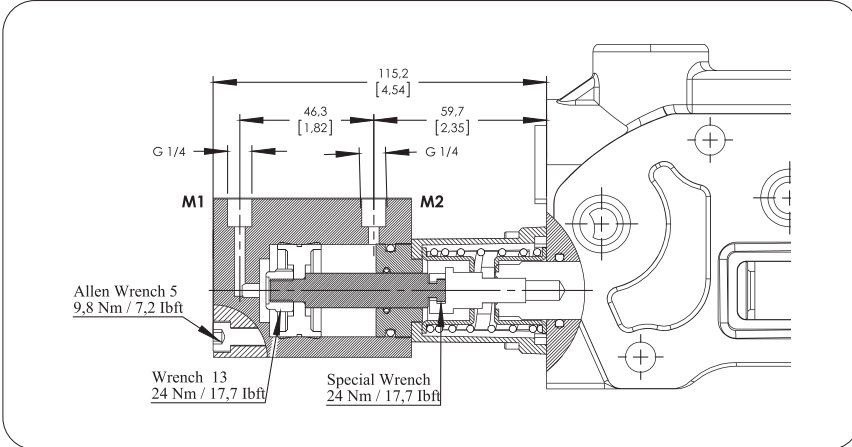

Operating Features

Pilot Pressure: 6 Bar (Max. 10) / 87 Psi (Max. 145)

ON/OFF Electro-Pneumatic Control

Kit No: **120EP**

Sectional Appearance

Diagram

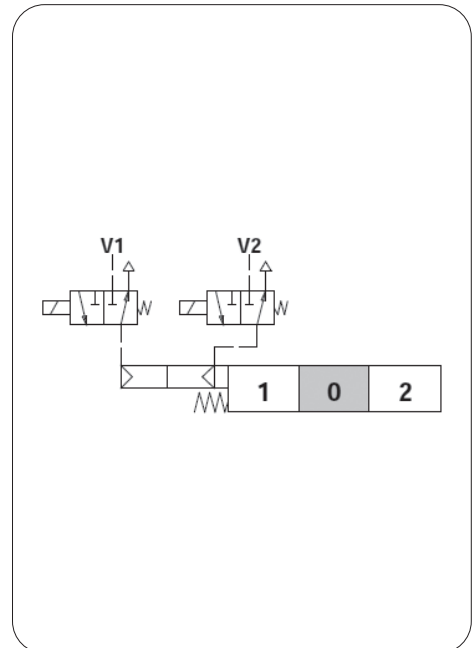
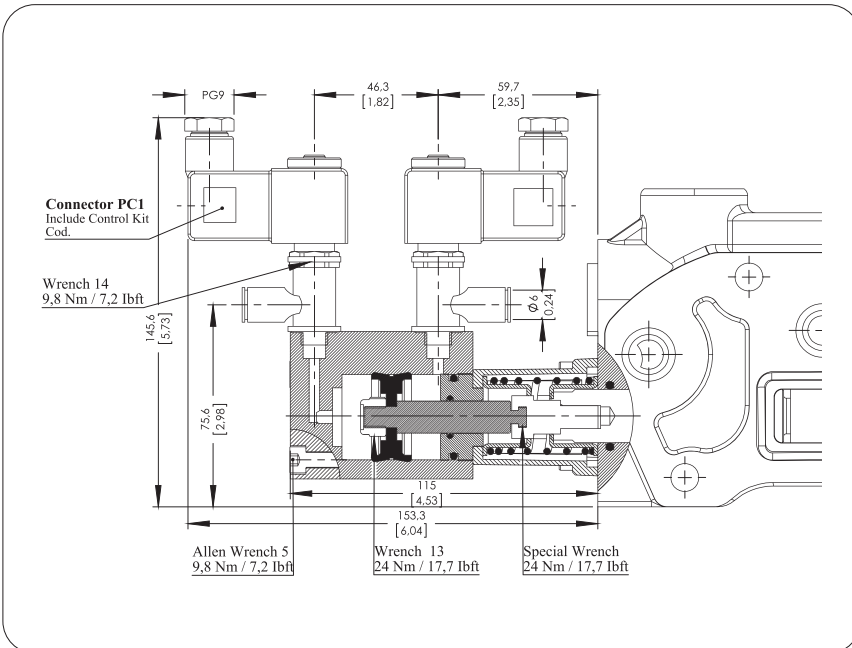

Operating Features

Pilot Pressure: 6 Bar (Max. 10) / 87 Psi (Max. 145)

Solenoid Operating Features

Nominal Voltage.....: 12VDC / 24 VDC

Power Rating.....: 6 W

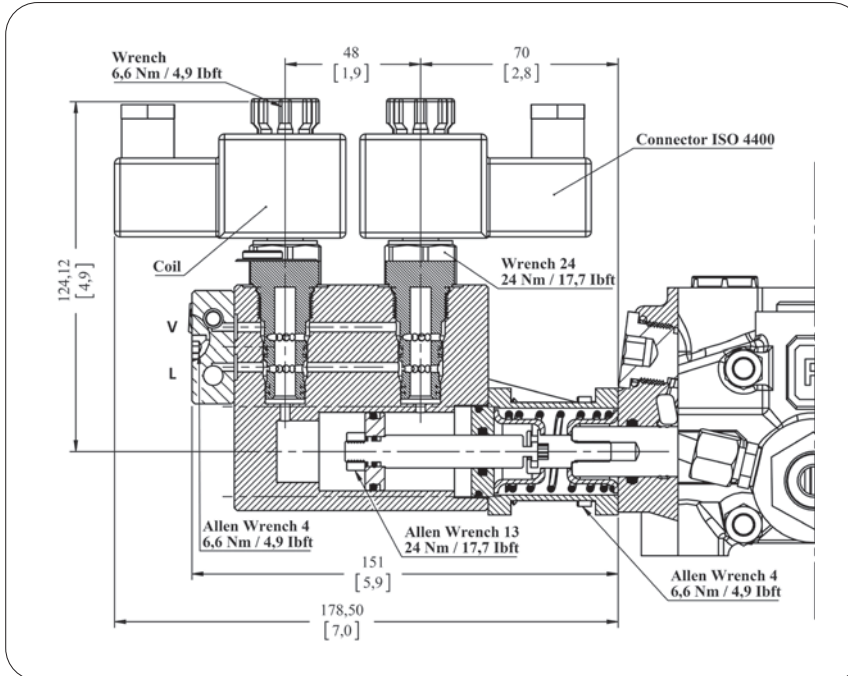
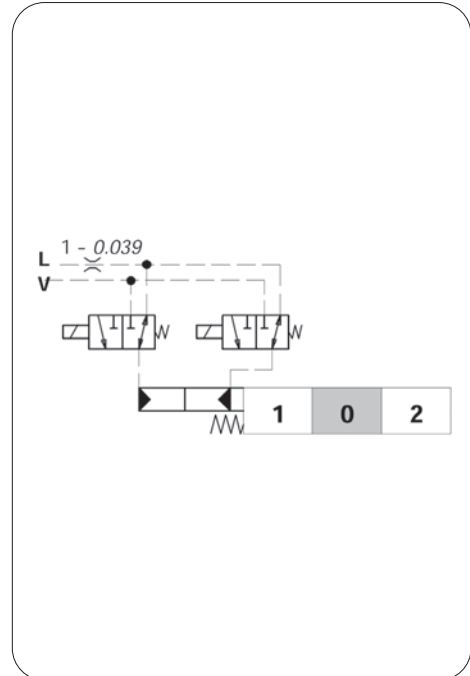
SPOOL POSITIONERS – SIDE OF RETURN
ON/OFF Electro - Hydraulic Control
Kit No: 120EH
Sectional Appearance

Diagram

Operating Features

Pilot Pressure: 10 Bar / 145 Psi
 : 50 Bar / 725 Psi
 Max back pressure on drain L.....: 25 Bar / 360 Psi

Solenoid Operating Features

Coil Connection.....: ISO 4400
 Nominal voltage.....: 12 VDC / 24 VDC
 Power rating.....: 21 W
 Duty cycle.....: %100
 Protection type.....: IP 65
 Nominal voltage tolerance.....: ±10
 Max temperatures.....: 100 C°
 Stroke.....: ±5,5 mm

ORDER CODE
External Pilot Collector

COL 11 - 10COL1001 – Kit For Section 1
 COL 12 - 10COL1001 – Kit For Section 2
 COL 13 - 10COL1001 – Kit For Section 3
 COL 14 - 10COL1001 – Kit For Section 4
 COL 15 - 10COL1001 – Kit For Section 5
 COL 16 - 10COL1001 – Kit For Section 6
 COL 17 - 10COL1001 – Kit For Section 7
 COL 18 - 10COL1001 – Kit For Section 8

Standard Pilot Collector

COL 21 - 10COL2001 – Kit For Section 1
 COL 22 - 10COL2001 – Kit For Section 2
 COL 23 - 10COL2001 – Kit For Section 3
 COL 24 - 10COL2001 – Kit For Section 4
 COL 25 - 10COL2001 – Kit For Section 5
 COL 26 - 10COL2001 – Kit For Section 6
 COL 27 - 10COL2001 – Kit For Section 7
 COL 28 - 10COL2001 – Kit For Section 8

SPOOL POSITIONERS – SIDE OF RETURN

ON/OFF Electro - Hydraulic Control Connections

Connection Type 1: Collector kit for external pilot and drain

Sectional Appearance

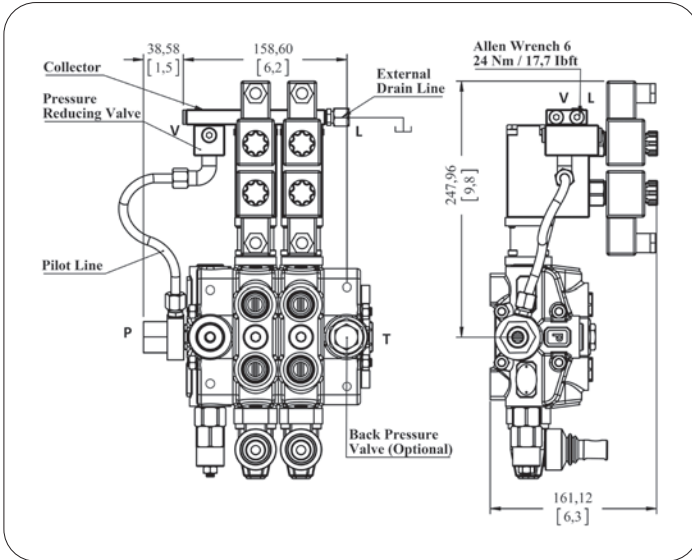

Diagram

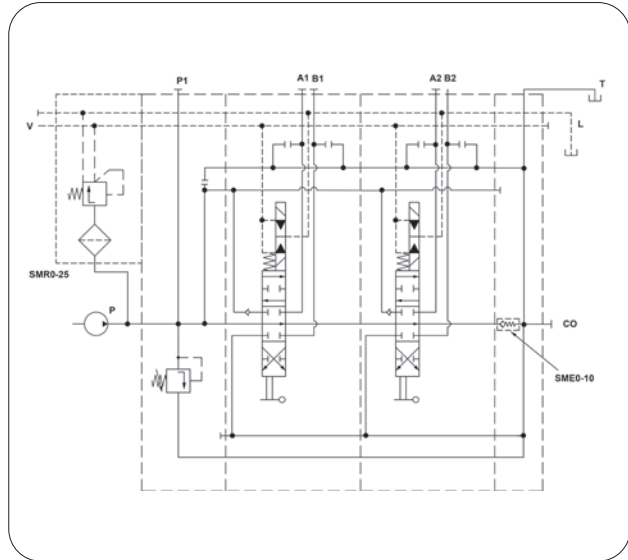

Operating Features

External Pressure Reducing Valve: 20 Bar / 290 Psi (For V line)

Code= GMM PD120-2P (SD(LA)-SMR2-125-PP)/P-1A-STL-120EH/ P-1A-STL-120EH (SMR0 -COL12-12V)/ SO-PT1 / SGT

Connection Type 2: Collector kit with pilot and drain lines

Sectional Appearance

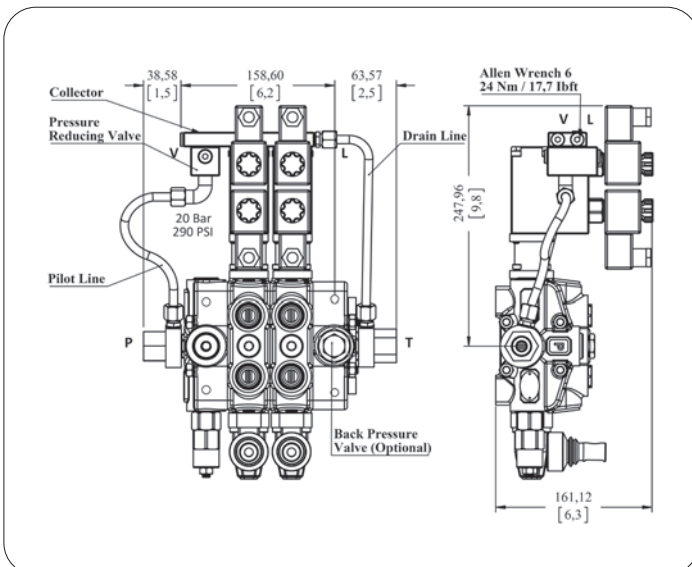

Diagram

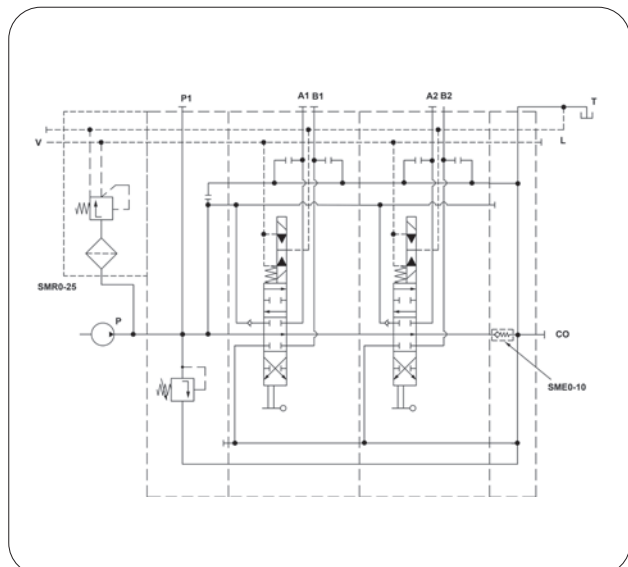

SMR 0-25 Valve Operating Features (Pressure reducing valve)

Outlet Pressure: 20 Bar / 290 Psi

Max. Flow.....: 8 l/min

Filtering: 80 µ

Code= GMM PD120-2P (SD(LA)-SMR2-125-PP)/P-1A-STL-120EH/ P-1A-STL-120EH (SMR0 -COL22-12V)/ SO-PT1 / SGT

WORKING SECTION KIT

With Port Valves Type

Kit No: **AA**

Sectional Appearance

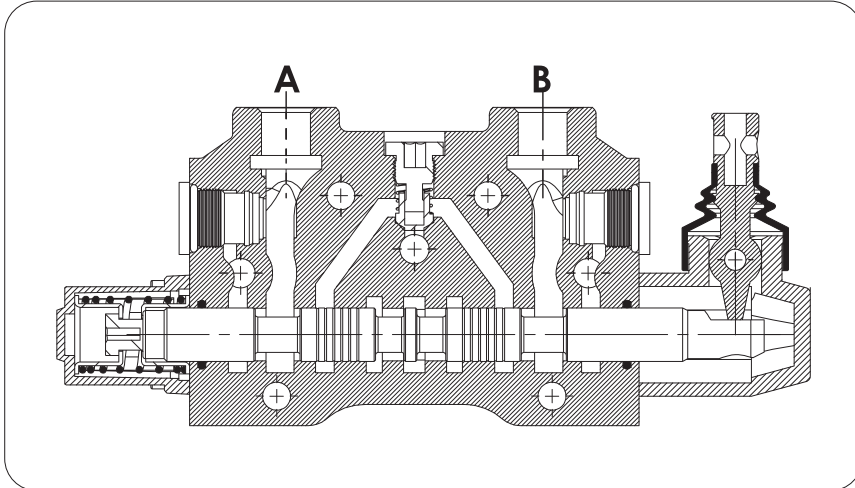

Diagram

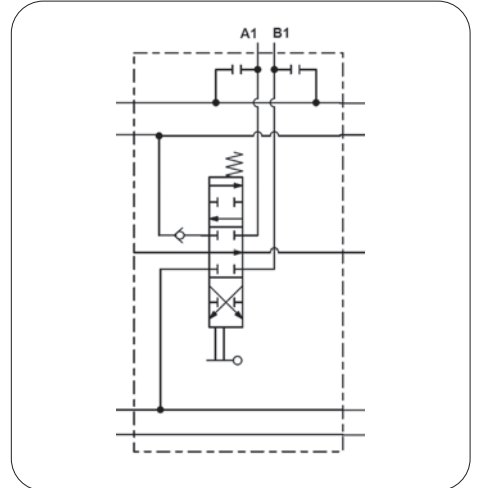

With Port Valves Type

Kit No: **AB**

Sectional Appearance

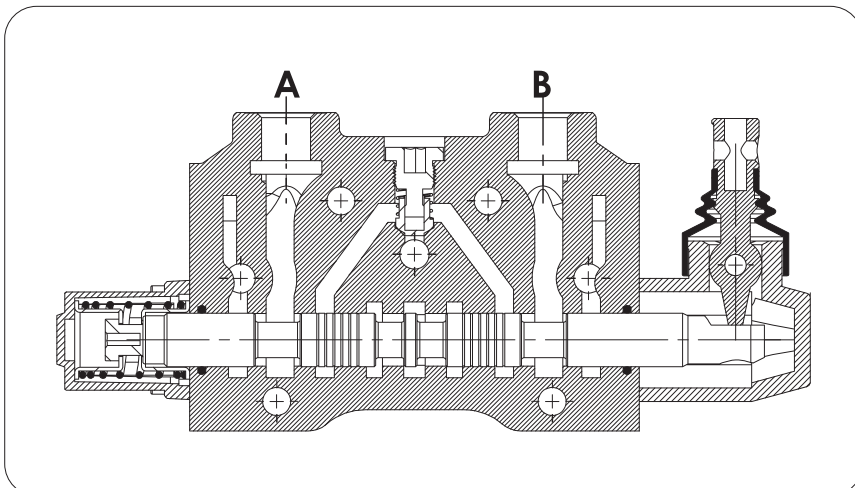

Diagram

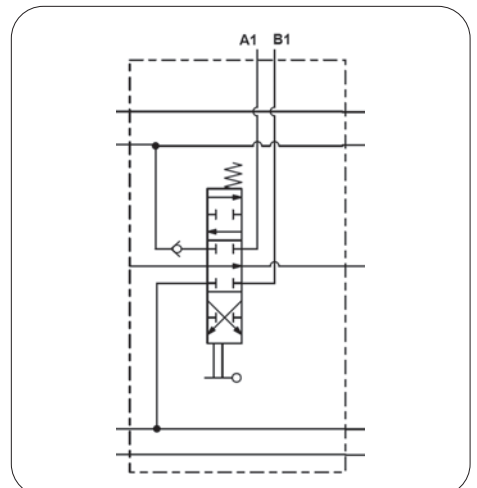

SPOOL POSITIONERS – SIDE OF LEVER CONTROL

Lever Controls

Kit No: **STL - L0**

Sectional Appearance

Diagram

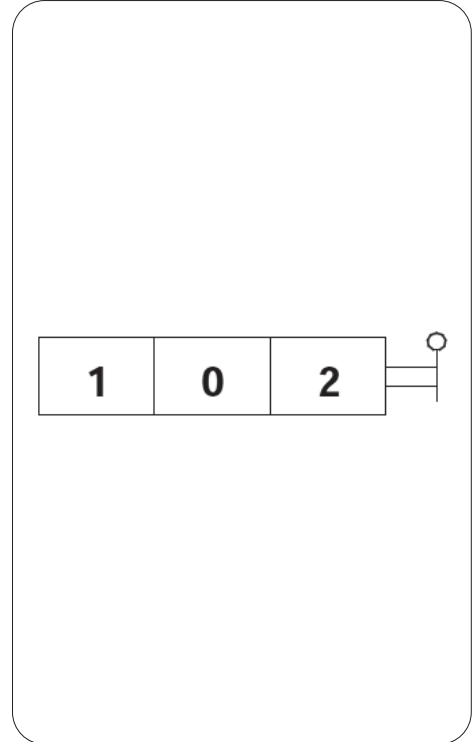
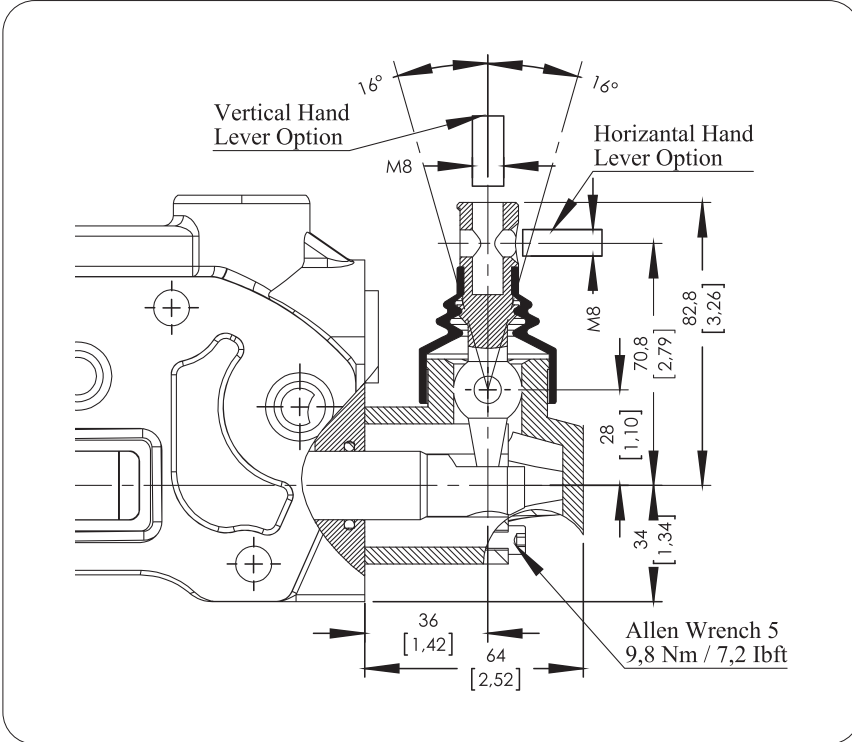

Kit No: **STL - L180**

Sectional Appearance

Diagram

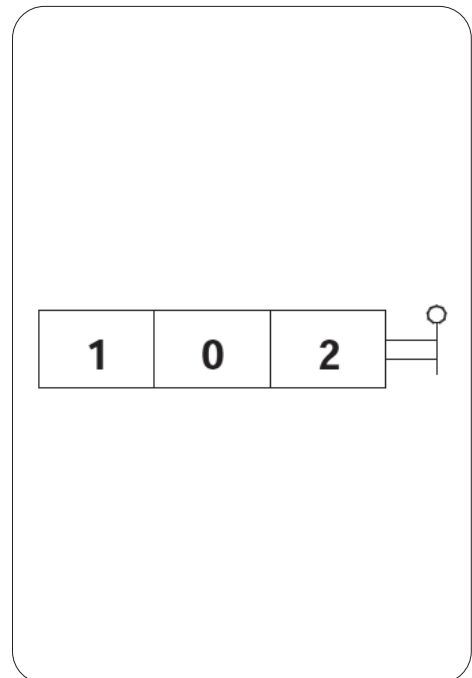
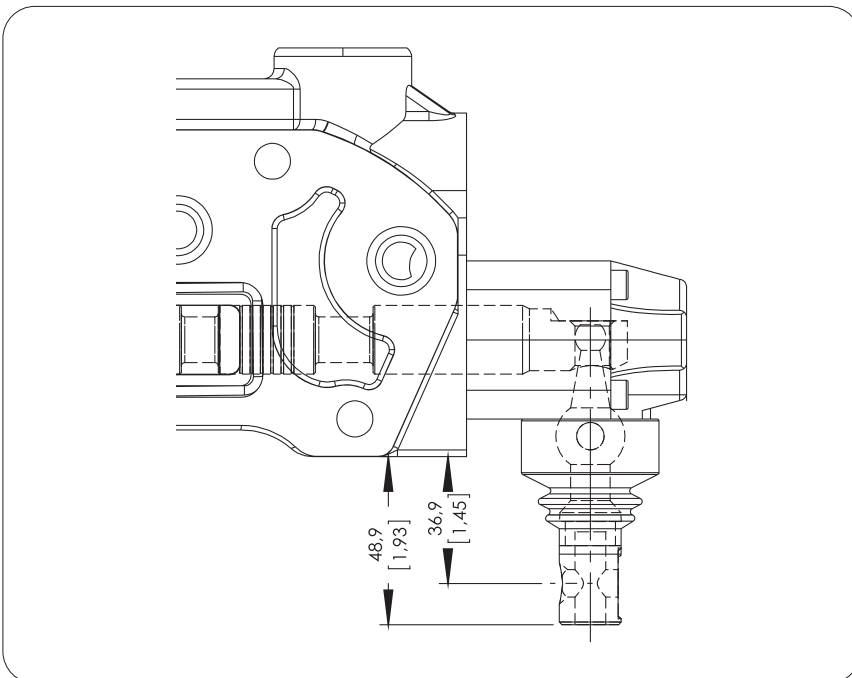

Note: Arm lever pivot box is aluminium cap protected. And it can be rotated 180°.

SPOOL POSITIONERS – SIDE OF LEVER CONTROL

Lever Controls – Joystick

Kit No: JL

Exploded View

Diagram

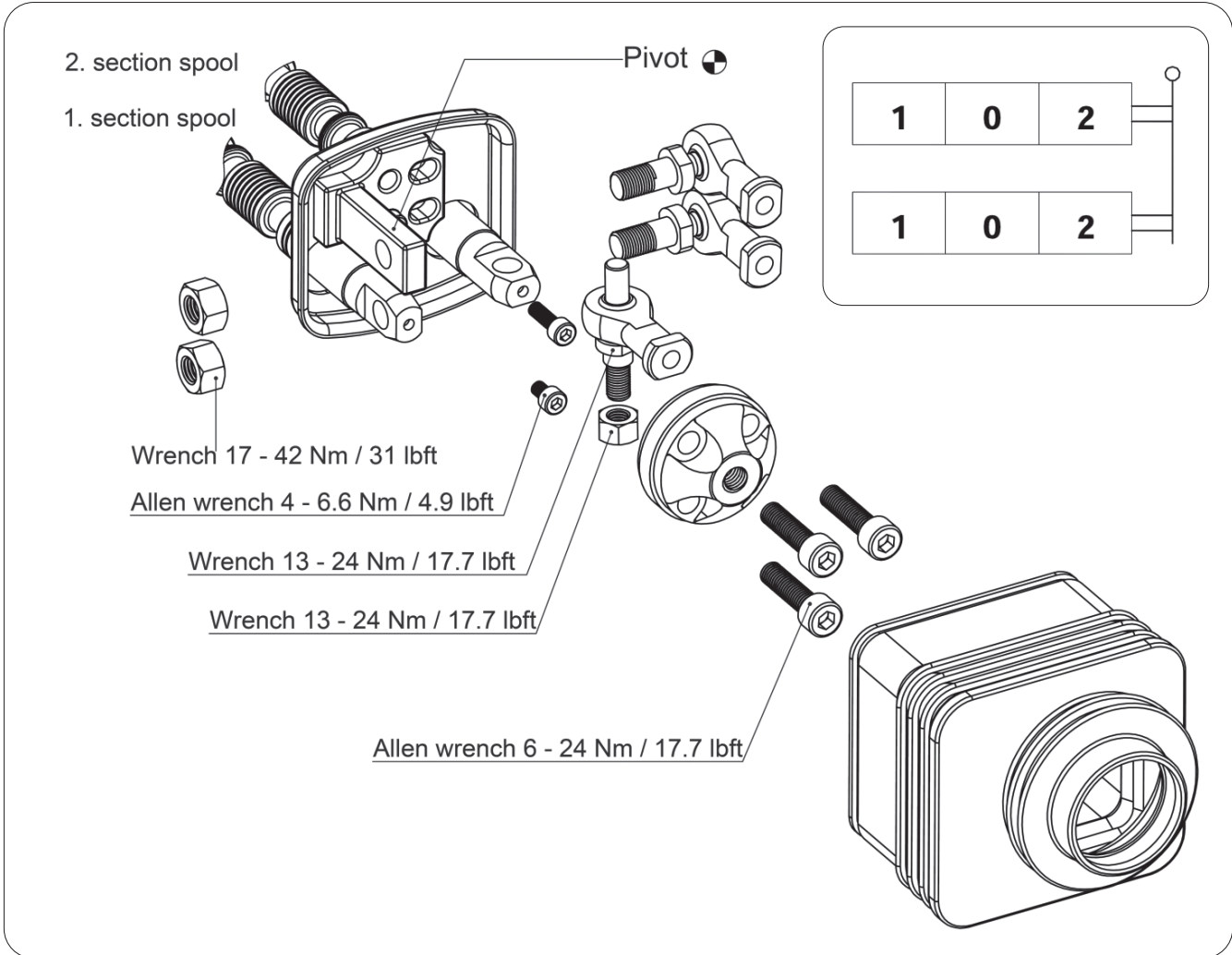

Operation Angle:

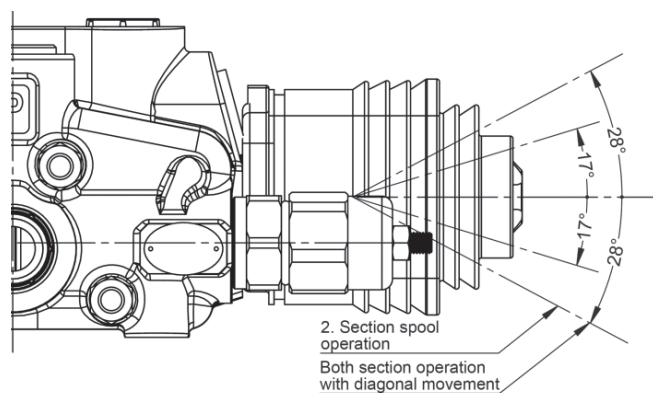
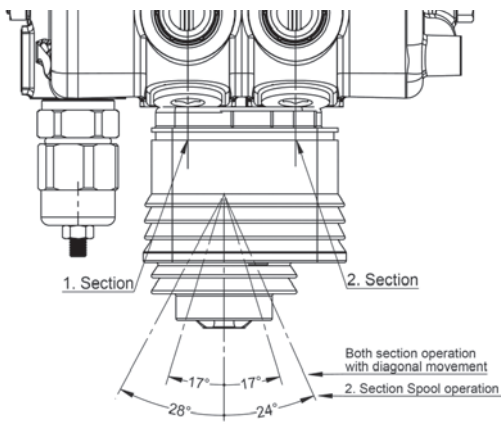

SPOOL POSITIONERS – SIDE OF LEVER CONTROL

Lever Controls – Joystick

Dimensions and movement sceme

Type No: **JL1**

Application: Pivot placed down on the Left

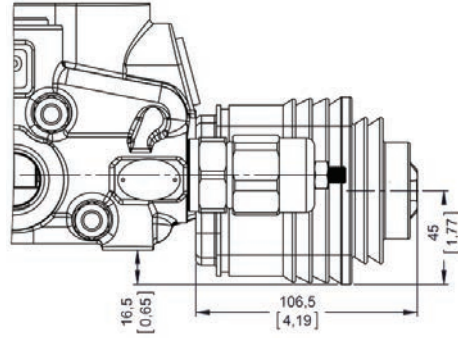
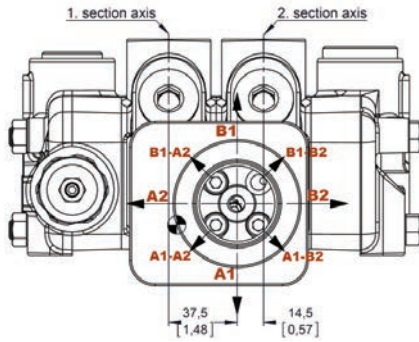

Type No: **JL2**

Application: Pivot placed down on the right

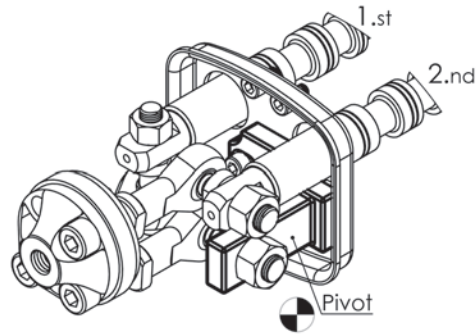
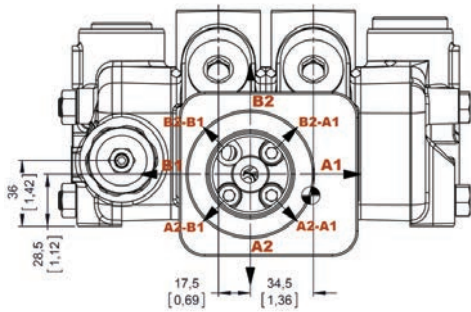

Type No: **JL3**

Application: Pivot placed above on the Left

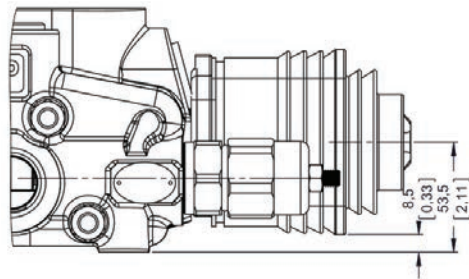
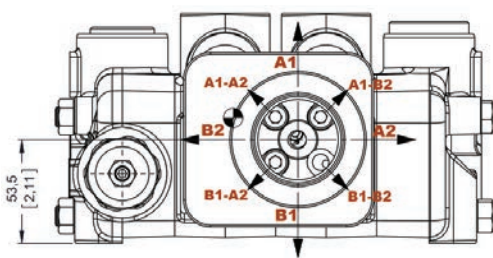

Type No: **JL4**

Application: Pivot placed above on the right

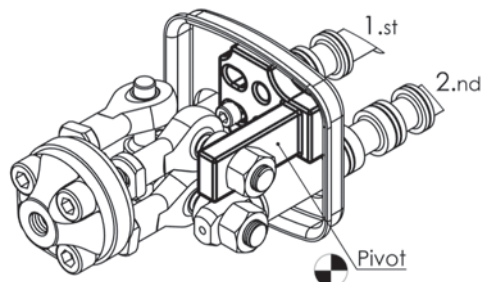
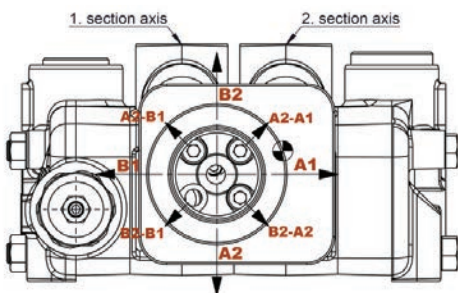

SPOOL POSITIONERS – SIDE OF LEVER CONTROL

Lever Controls - Cable Control

Kit No: HL

Sectional Appearance

Diagram

Waterproof cap prearranged for remote control with flexible cable.

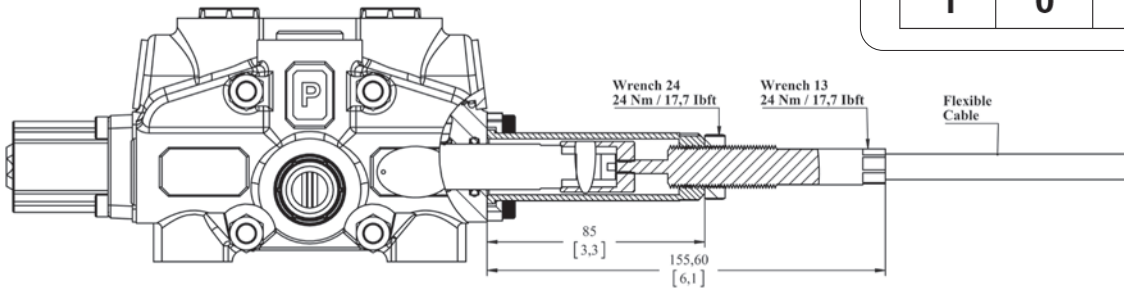

Note: Remote cable control is several options. Please indicote the cable length demanded and contact our sales department.

Example Operation

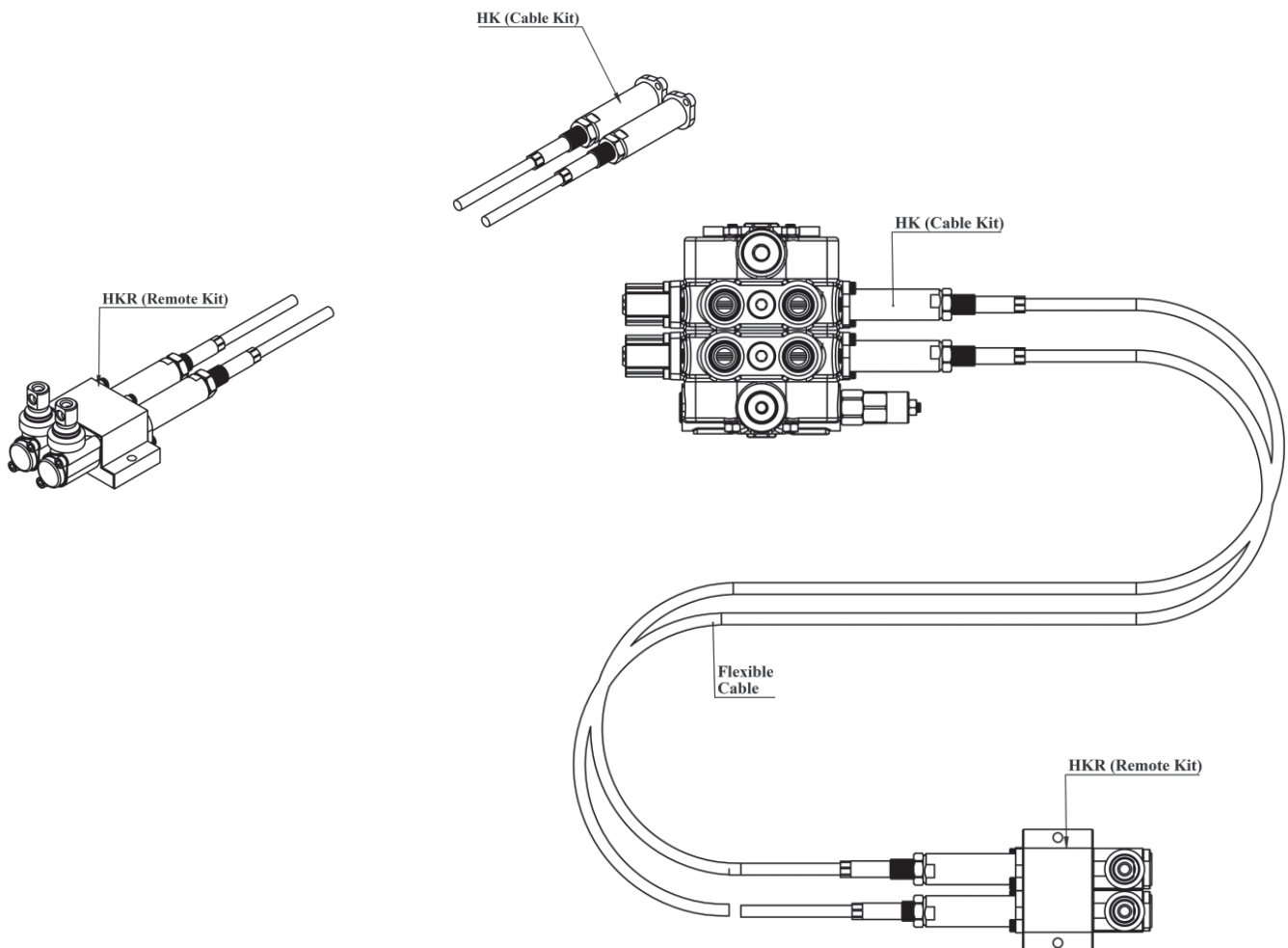

OUTLET COVER - TANK SIDE

Output Cover Options

Kit No: SO

Sectional Appearance

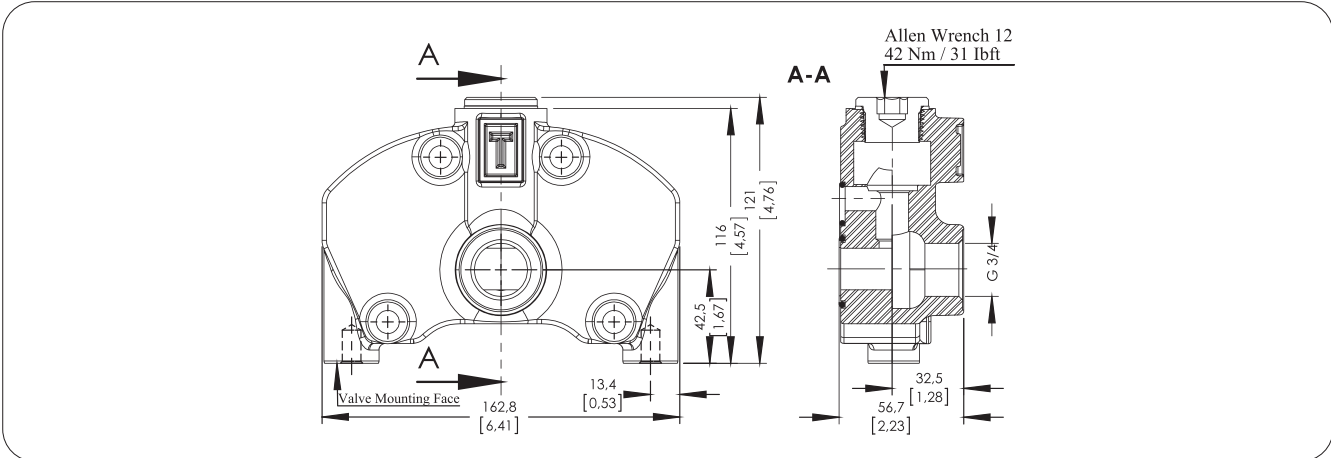

Type No: TO

Sectional Appearance

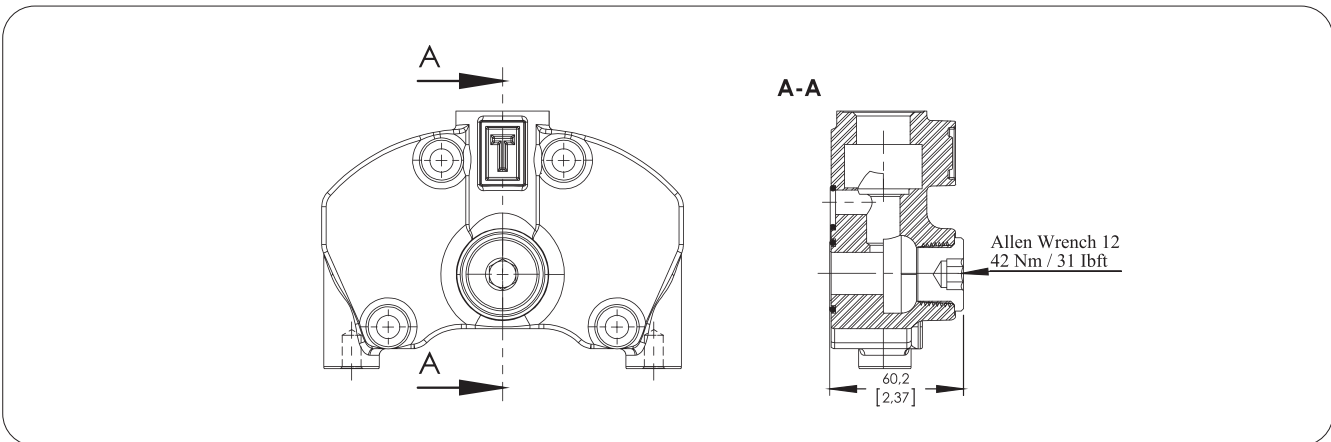

Hydraulic Diagram

Type No: SO

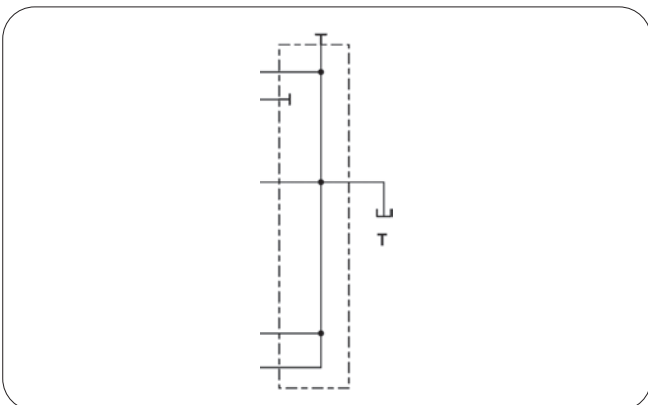

Type No: TO

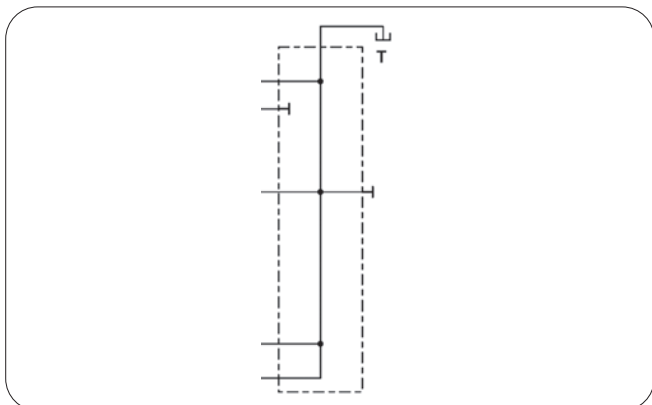

OUTLET COVER - TANK SIDE

Output Cover Options

Kit No: TCO

Sectional Appearance

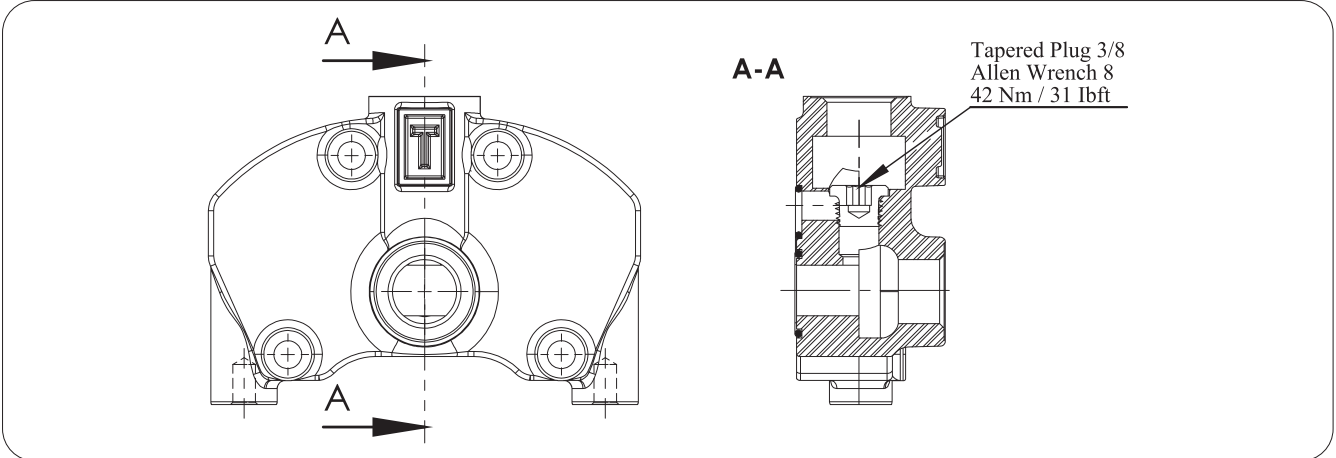

Kit No: TC

Sectional Appearance

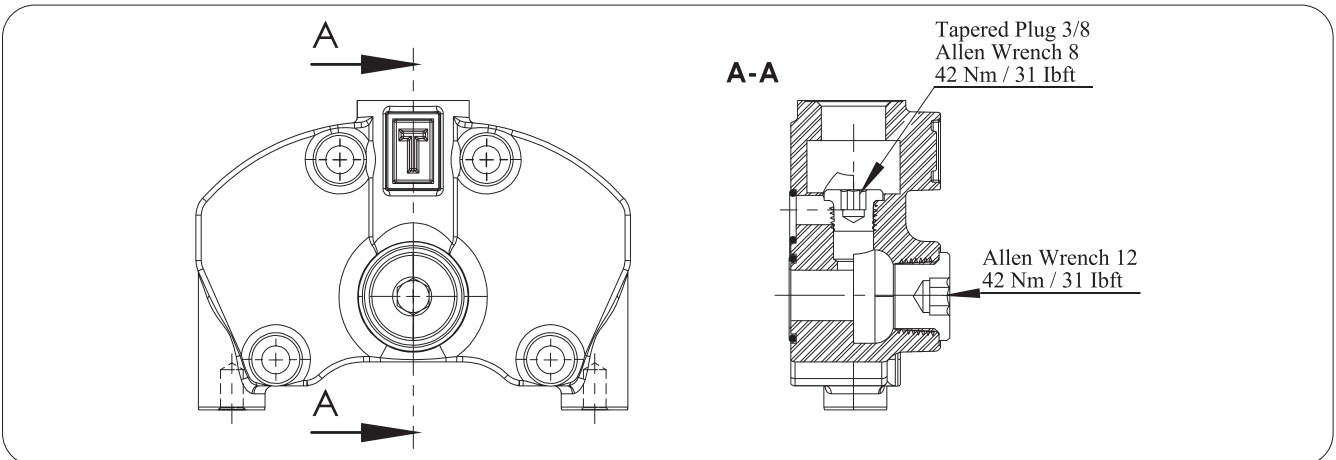

Hydraulic Diagram

Type No: TCO

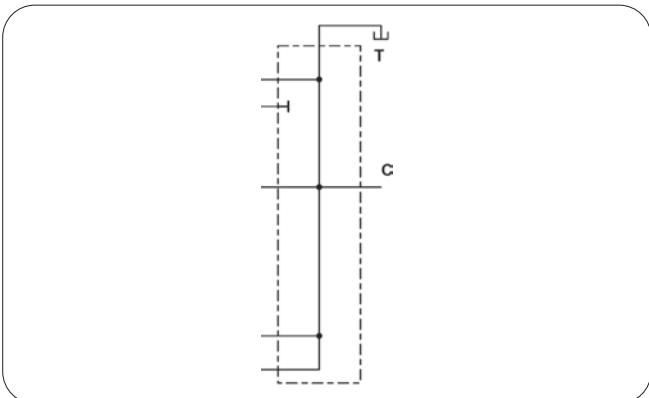

Type No: TC

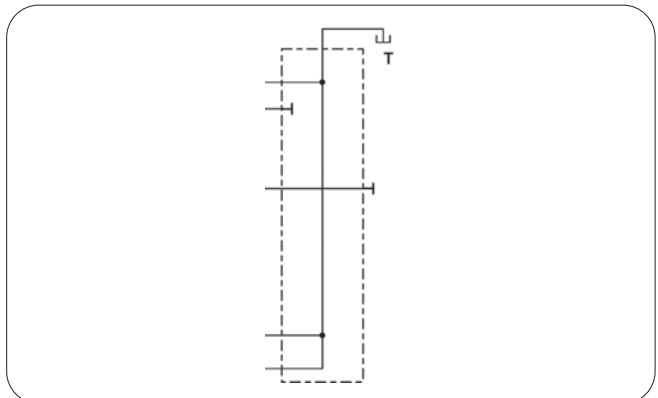

PORT VALVES OPTIONS

Anti Shock Valves

Code:

YAS-1 (T1-100)

→ Pressure Setting in Bar

→ Adjusting type T=With screw , L=Valve Set / Spring Type (1,2,3)

→ 1 = Mounted Port A , 2 = Mounted Port B , 3 = Mounted Port A and B

Hydraulic Diagram

Kit No: **YAS1**

Kit No: **YAS2**

Kit No: **YAS3**

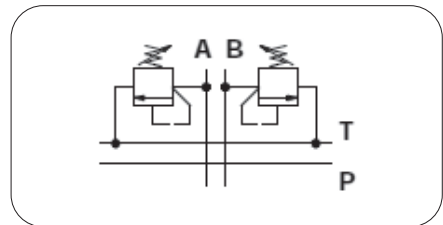
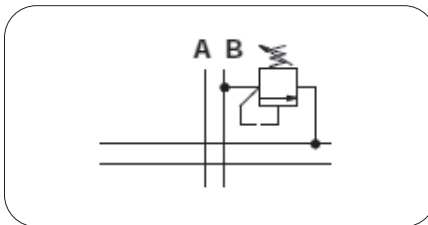
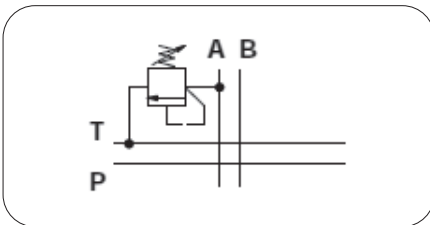

Adjustment Type on Valve:

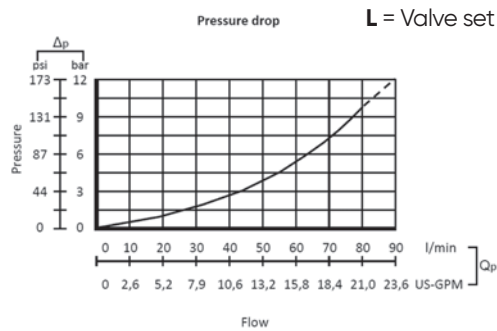
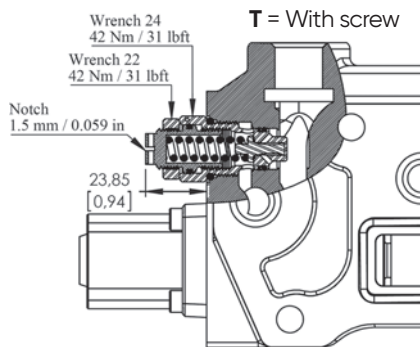

Performance Data:

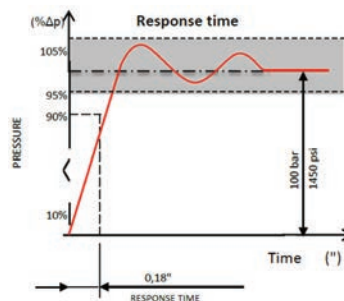
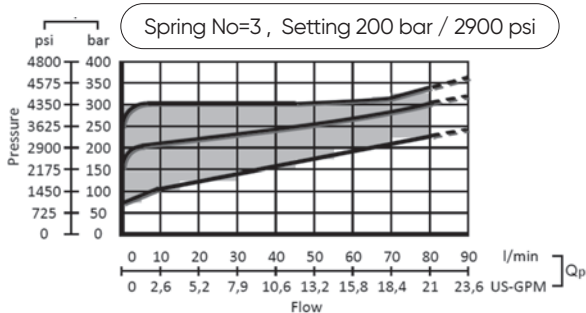
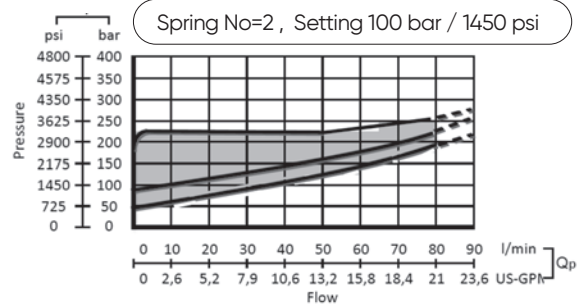
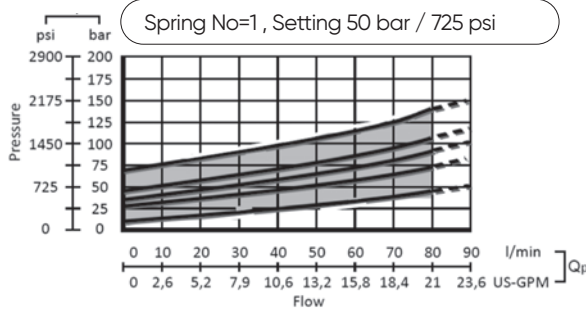

PORT VALVES OPTIONS

Anti shock And Anti Cavitation Valves

Code:

YAA-1 (T1-100)

Pressure Setting in Bar

Adjusting type T=With screw , L=Valve Set / Spring Type (1,2,3)

1 = Mounted Port A , 2 = Mounted Port B , 3 = Mounted Port A and B

Hydraulic Diagram

Kit No: YAA1

Kit No: YAA2

Kit No: YAA3

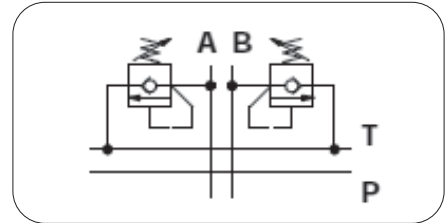
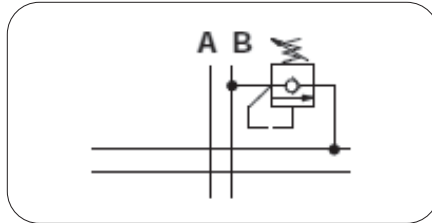
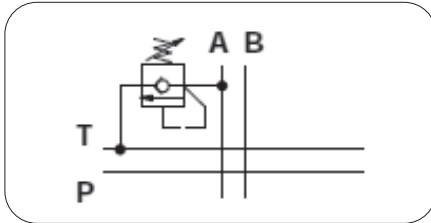

Adjustment Type on Valve:

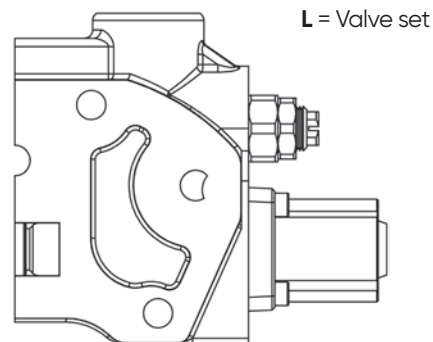
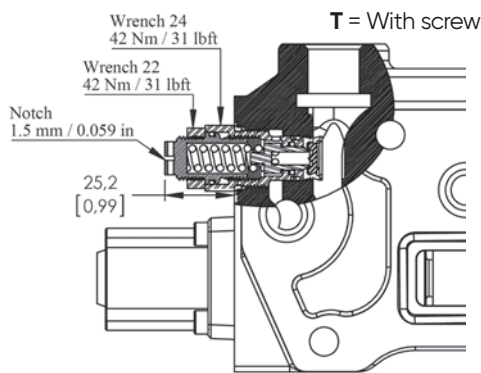

Performance Data:

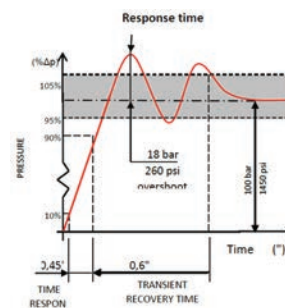
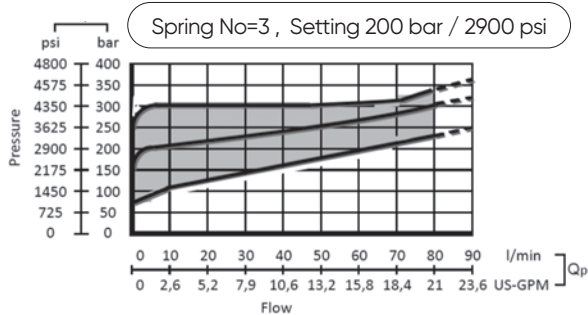
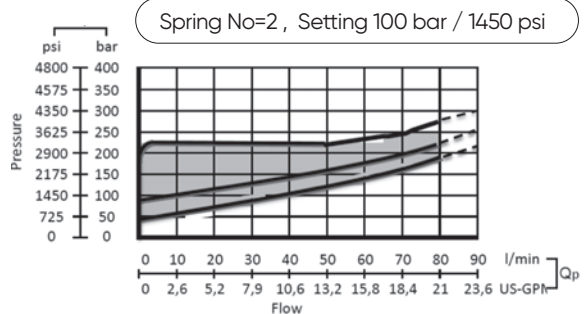
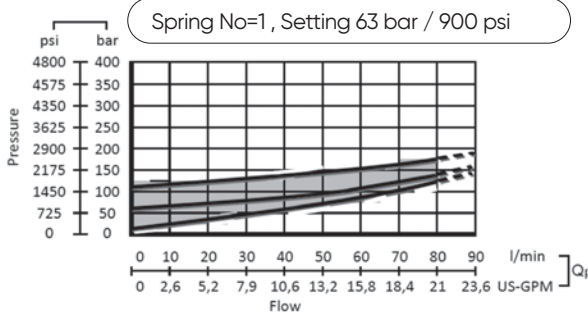

PORT VALVES OPTIONS

Anti Cavitation Valves

Code:

YAC-1

→ 1= Mounted Port A , 2=Mounted Port B , 3=Mounted Port A and B

Hydraulic Diagram

Kit No: **YAC1**

Kit No: **YAC2**

Kit No: **YAC3**

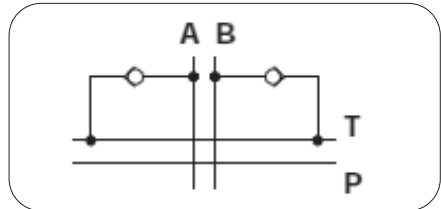
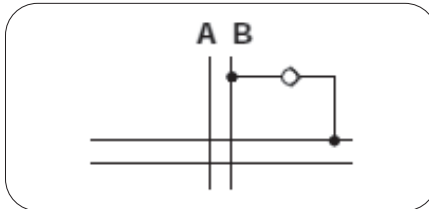
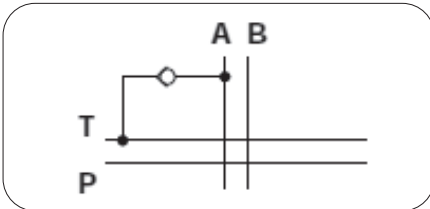

Adjustment Type on Valve And Data:

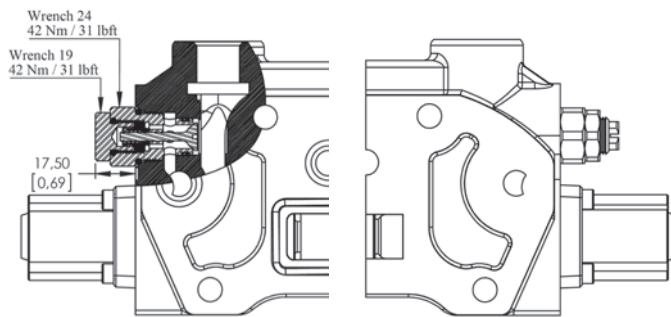

Valve Blanking

Plug with tank connection

DST-1 (1:Mounted port A – 2:Mounted port B)

Sectional Appearance

Hydraulic Diagram

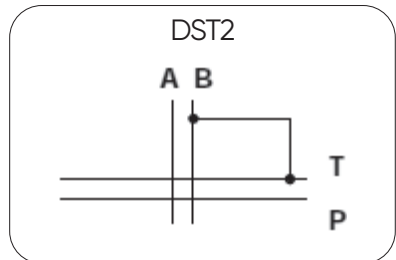
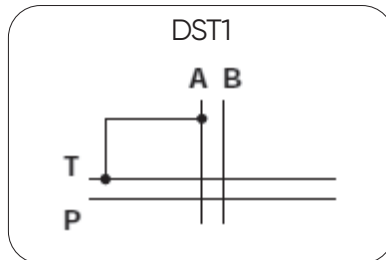
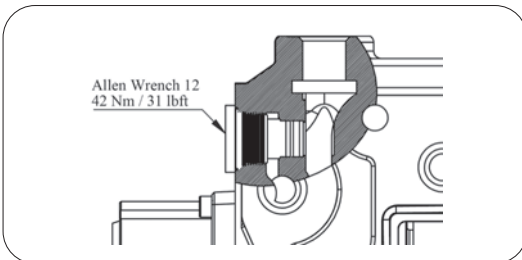

Plug

YP-1 (1:Mounted port A – 2:Mounted port B – 3:Mounted port A and B)

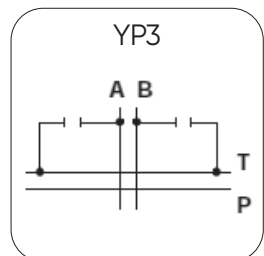
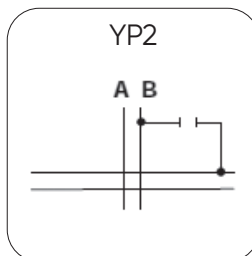
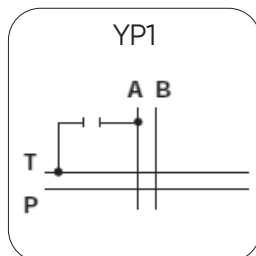
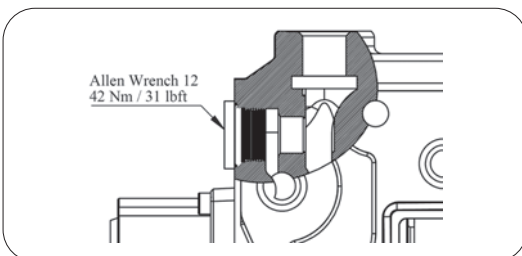

INSTALLATION AND MAINTENANCE

The GMM-PD120 valve is assembled and tested as per the technical specification of this catalog. Before the final installation on your equipment, follow the below recommendation:

- The valve can be assembled in any position, in order to prevent body deformation and spool sticking mount the product on a flat surface;
- In order to prevent the possibility of water entering the lever box and spool control kit, do not use high pressure wash down directly on the valve;
- Before painting, ensure plastic port plugs are tightly in place.

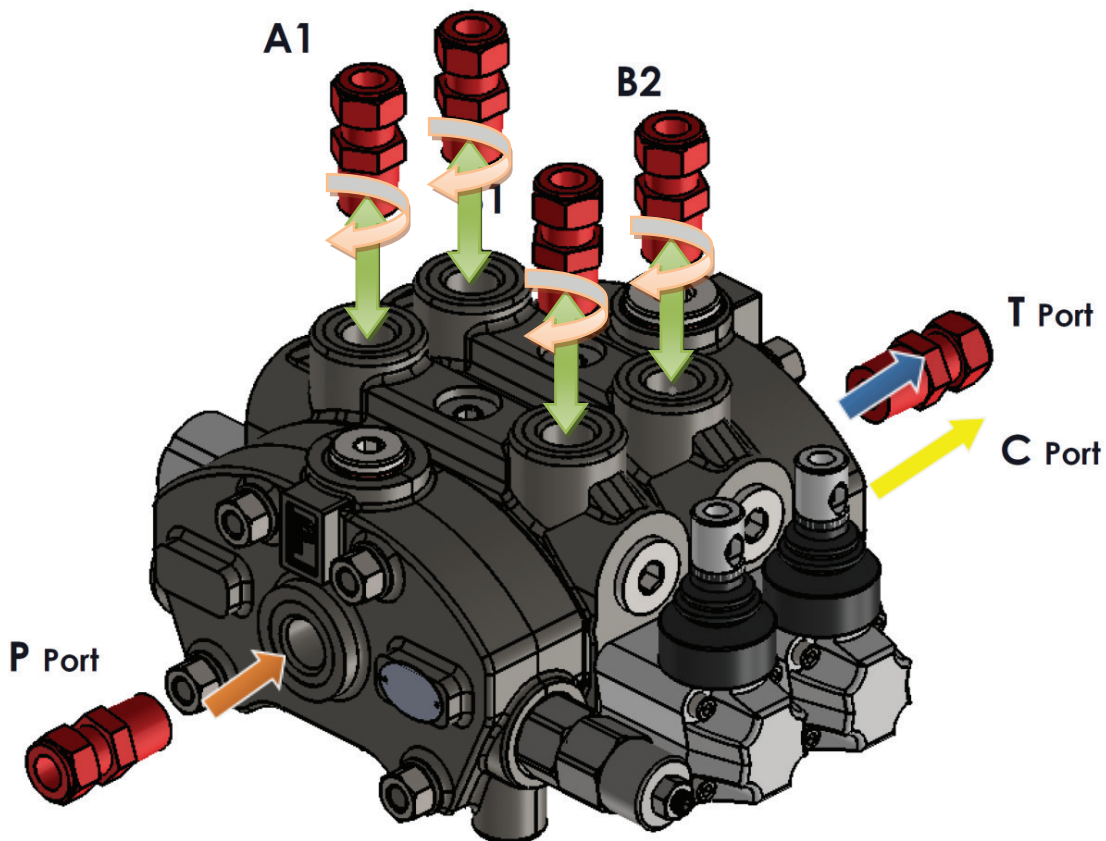

Threads Type (Nm / lbft)	P Port	A and B Port	T Port
BSP (ISO 228/1)	G 1/2	G 1/2	G 3/4
With O--Ring seal	50 / 36.9	50 / 36.9	70 / 51.6
With copper washer	60 / 44.3	60 / 44.3	70 / 51.6
With steel and rubber washer	60 / 44.3	60 / 44.3	70 / 51.6
BSP (ISO 228/1)	G 3/4	G 3/4	G 3/4
With O--Ring seal	70 / 51.6	70 / 51.6	70 / 51.6
With copper washer	70 / 51.6	70 / 51.6	70 / 51.6
With steel and rubber washer	70 / 51.6	70 / 51.6	70 / 51.6
UN--UNF (ISO 11926--1)	11/16--12 UNF--2B	7/8--16 UNF--2B	11/16--12 UNF--2B
With O--Ring seal	95 / 70	30 / 22.1	95 / 70

TECHNICAL DATA

Ports Dimensional Data

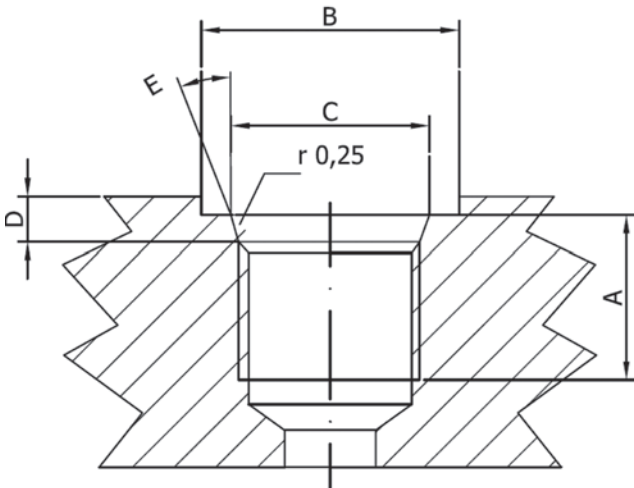

SAE UN-UNF (ISO 725)							
Dimensions		7/8-14 UNF SAE10		1"1/16-12 UN SAE12		1"5/16-12 UN SAE16	
mm	in						
A		17	0,67	20	0,79	20	0,79
B		34	1,34	41	1,61	49	1,92
C		23,9	0,94	29,2	1,15	35,5	1,40
D		2,5	0,10	3,3	0,13	3,3	0,13
E		15°		15°		15°	

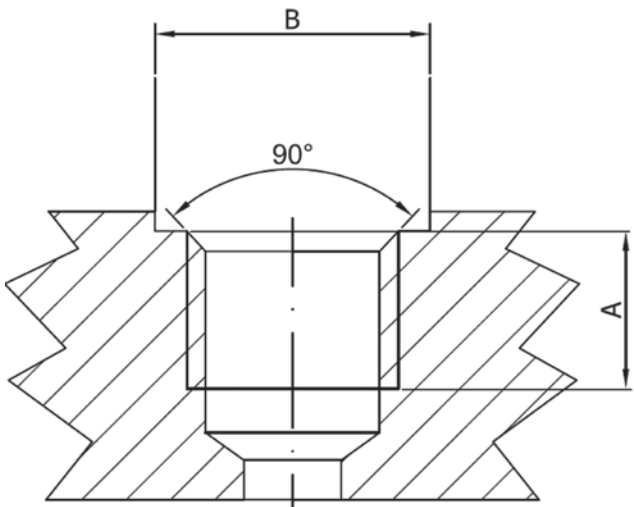

BSP (ISO 228)							
Dimensions		G 1/2"		G3/4		G1	
mm	in						
A		16	0,63	18	0,71	20	0,79
B		27	1,06	33	1,30	40	1,57

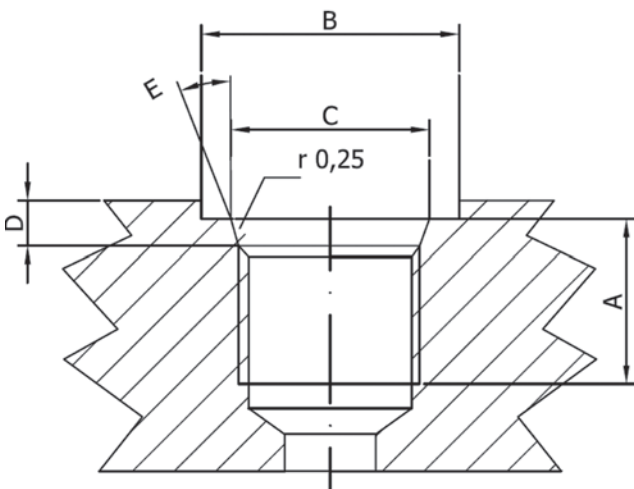

METRIC (ISO 262)							
Dimensions		M22x1,5 ISO 262		M27x2 ISO 262			
mm	in						
A		16	0,63	18	0,71		
B		31,5	1,24	37,7	1,48		