

## ISUZU HINO L100-108

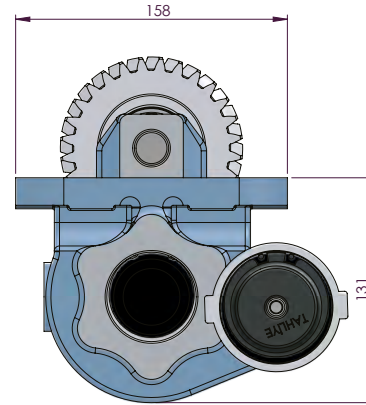
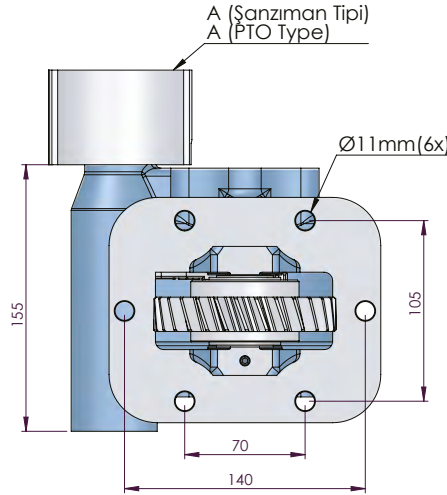
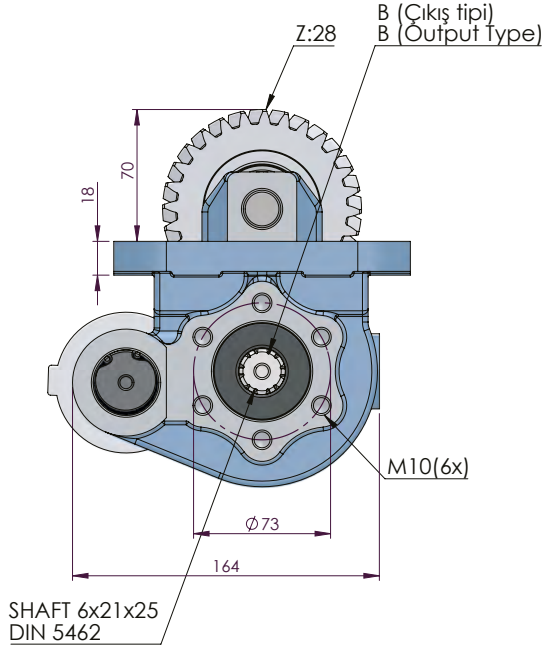

ISUZU

POWER TAKE-OFFS  
P.T.O.

CODE KOD	TYPE TİP (A)	MOUNTING TYPE BAĞLANTI TİPİ (B)	MOUNTING SIDE BAĞLANTI	TORQUE TORK (Kgm / Nm)	POWER GÜÇ (Hp / Kw)	SPEED DEVİR (RPM)	RATIO ORAN
50650512M0	MECHANİK MEKANİK	UNI	SIDE YAN	18 Kgm 182 Nm	15 Hp 11 Kw	600 RPM	1:1,3
50650522M0		ISO ADAPTER / ADAPTÖRLÜ ISO					
50650532M0		FLANGE / FLANŞLI					
50650542M0		SHAFT / ŞAFTLI					
50650512V0	VACUUM VAKUMLU	UNI	SIDE YAN	18 Kgm 182 Nm	15 Hp 11 Kw	600 RPM	1:1,3
50650522V0		ISO ADAPTER / ADAPTÖRLÜ ISO					
50650532V0		FLANGE / FLANŞLI					
50650542V0		SHAFT / ŞAFTLI					
GEARBOX / ANA ŞANZIMANLAR				USED VEHICLES / KULLANILAN BAZI ARAÇLAR			
33111-2065 / 08V0484 / 11Y0563 / 33121-1990 / 33121-1980				HINO L-100/FBC 112 SA			