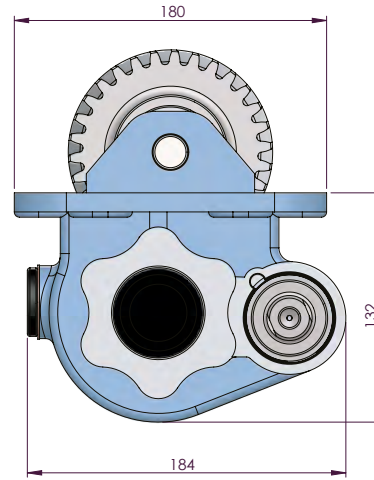
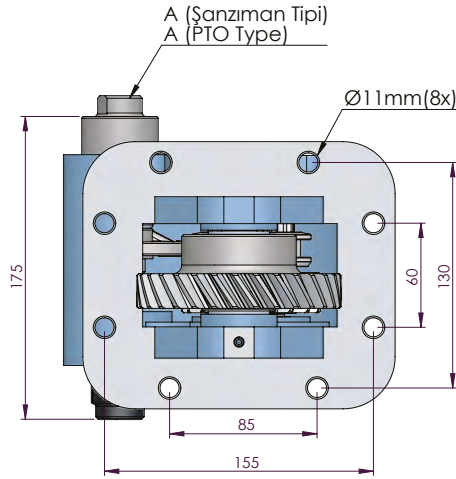
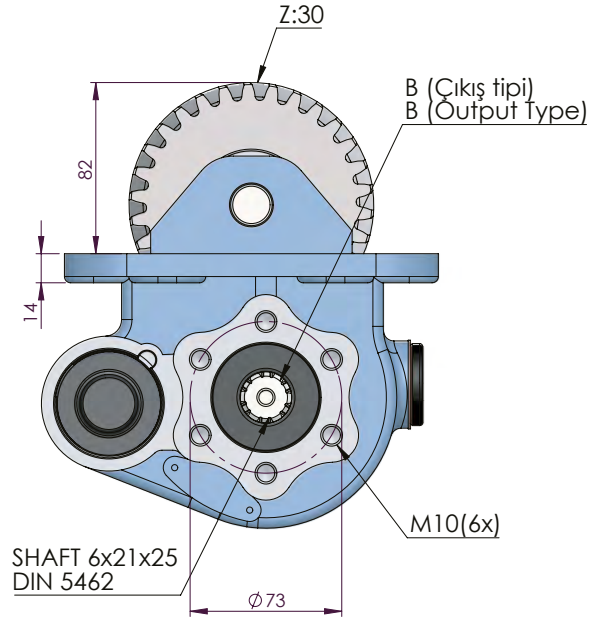

ISUZU HINO LX06S

ISUZU

 POWER TAKE-OFFS
 P.T.O.

CODE KOD	TYPE TİP (A)	MOUNTING TYPE BAĞLANTI TİPİ (B)	MOUNTING SIDE BAĞLANTI	TORQUE TORK (Kgm / Nm)	POWER GÜÇ (Hp / Kw)	SPEED DEVİR (RPM)	RATIO ORAN
50657512P0	PNEUMATIC PNÖMATİK	UNI	SIDE YAN	23 Kgm 225 Nm	32 Hp 24 Kw	2000 RPM	1:1,6
50657522P0		ADAPTÖRLÜ ISO ADAPTER ISO					
50657532P0		FLANGE / FLANŞLI					
50657542P0		SHAFT / ŞAFTLI					
GEARBOX / ANA ŞANZIMANLAR				USED VEHICLES / KULLANILAN BAZI ARAÇLAR			
LX06S / LX06X LX05S {6,515-8,190}				HIN0FG1J/GD1J/GD1JEUD-BAX/GD1JLUA-BAX/F61JMUB-B6X/F61JPUB-B6X/GH1JGDNGX/GH1JMUA-NGX / 51021 / 51017 / 51022 / 51322 / FT1JEUACG / FT1JGUA-CGX / FC4JJUA-NNL / FT1JEUAGL / GT1JFUA / GT1JHUA / HINO FC9J FC4JJRA JERA JLRA / F68J			