

# ISUZU HINO M153

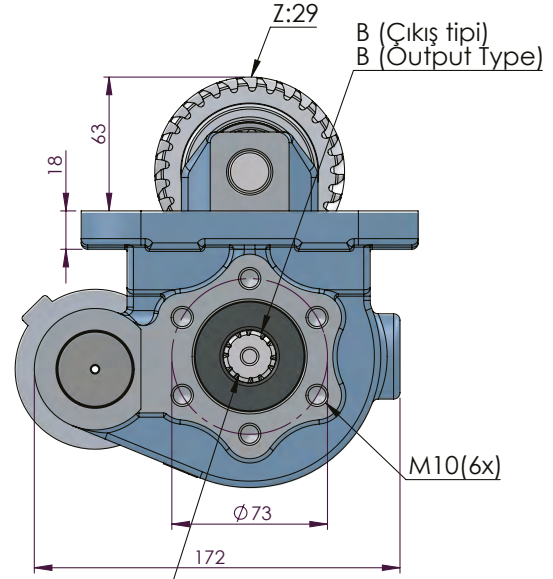

SHAFT 6x21x25  
DIN 5462

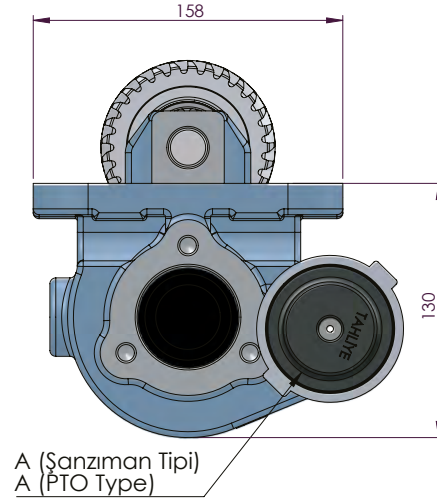
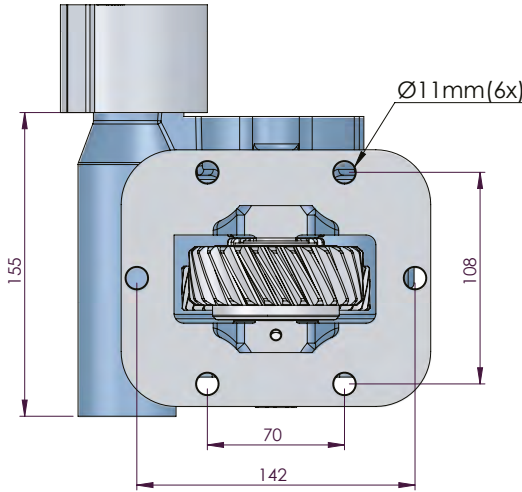

CODE KOD	TYPE TİP (A)	MOUNTING TYPE BAĞLANTI TİPİ (B)	MOUNTING SIDE BAĞLANTI	TORQUE TORK (Kgm / Nm)	POWER GÜÇ (Hp / Kw)	SPEED DEVİR (RPM)	RATIO ORAN
50654512M0	MECHANIC MEKANİK	UNI	SIDE YAN	18,6 Kgm 182,4 Nm	15,4 Hp 11,5 Kw	600 RPN	1:1,28
50654522M0		ISO ADAPTER / ADAPTÖRLÜ ISO					
50654532M0		FLANGE / FLANŞLI					
50654542M0		SHAFT / ŞAFTLI					
50654512V0	VACUUM VAKUMLU	UNI	SIDE YAN	18,6 Kgm 182,4 Nm	15,4 Hp 11,5 Kw	600 RPN	1:1,28
50654522V0		ISO ADAPTER / ADAPTÖRLÜ ISO					
50654532V0		FLANGE / FLANŞLI					
50654542V0		SHAFT / ŞAFTLI					
GEARBOX / ANA ŞANZIMANLAR				USED VEHICLES / KULLANILAN BAZI ARAÇLAR			
M153 / M150 / M 155 / M151 / M52 / H50 / H 260 / 4VB / 5VB				HINO 300 DUTRO / TOYOTA WU 412L / DAIHATSU DELTA / TOYOTA DYNA H260-200-400 / HINO 611 WU355B WU710L-HKMQJV3 / WU700L-HKMQJV3 / WU720 / HINO 300-711 / WU342L / WU302L / HINO DUTRO WU 720			