

ISUZU MBP 6P

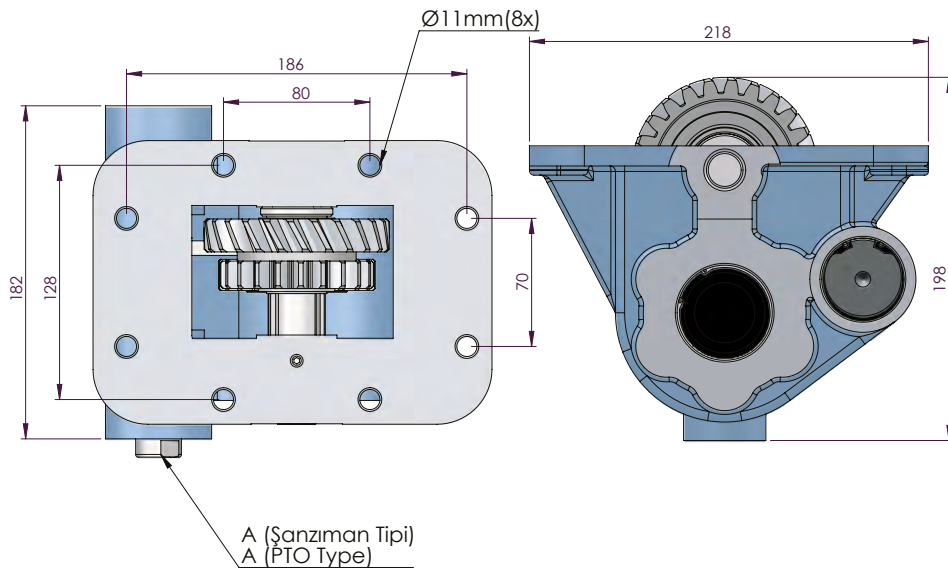
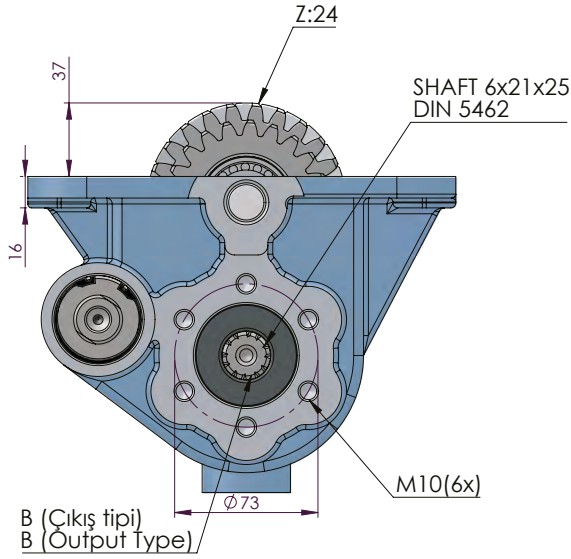

ISUZU

POWER TAKE-OFFS
P.T.O.

CODE KOD	TYPE TİP (A)	MOUNTING TYPE BAĞLANTI TİPİ (B)	MOUNTING SIDE BAĞLANTI	TORQUE TORK (Kgm / Nm)	POWER GÜÇ (Hp / Kw)	SPEED DEVİR (RPM)	RATIO ORAN
50613512M0	MECHANIC MEKANİK	UNI	SIDE YAN	18 Kgm 176,6 Nm	14,2 Hp 10,6 Kw	550 RPM	1:0,95
50613522M0		ISO ADAPTER ADAPTÖRLÜ ISO					
50613532M0		FLANGE FLANŞLI					
50613542M0		SHAFT ŞAFTLI					
50613512P0	PNEUMATIC PNÖMATİK	UNI	SIDE YAN	18 Kgm 176,6 Nm	14,2 Hp 10,6 Kw	550 RPM	1:0,95
50613522P0		ISO ADAPTER ADAPTÖRLÜ ISO					
50613532P0		FLANGE FLANŞLI					
50613542P0		SHAFT ŞAFTLI					
GEARBOX / ANA ŞANZIMANLAR				USED VEHICLES / KULLANILAN BAZI ARAÇLAR			
MBP - 6P / MBF - 5C / MBG - 6P-6Q / MBG - 5A / MBG-5H / MBD-5A,5B,5C,6P / MBJ-5J,6T / MBP-6A, 6R / MBG-5B,5C,5F,5R,6Q,6P,6R(550 RPM, SAĞ)				NQR 4.8 TURBO ISUZU / NQR 70 P / FSR / LM524 / FSR 33L / FRR 33H / FTS 33H 7 FSS 33 / EXZ52 / FRR 33L			

Seçeğinizin pompanın dönüş yönü, P.T.O. dönüş yönü ile ters olmalıdır.
The rotation of the choosen pump has to be opposite with the rotation of P.T.O.

P.T.O. montaj edildikten sonra ana şanzıman yağını tamamlayın.
Fill the oil of the gear box after mounting the P.T.O.

gemmahydraulic.com