

ISUZU MLD 6Q

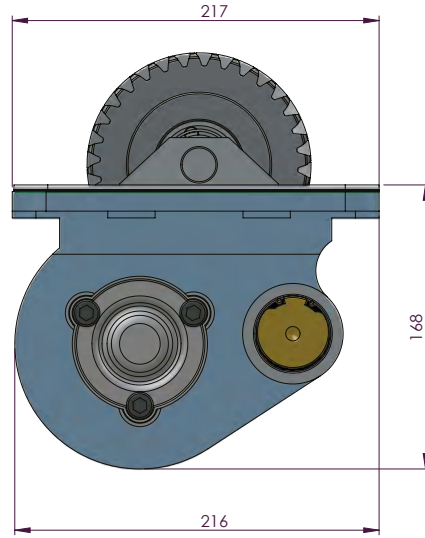
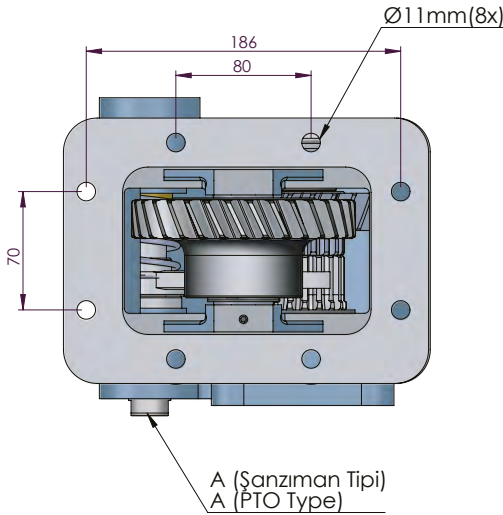
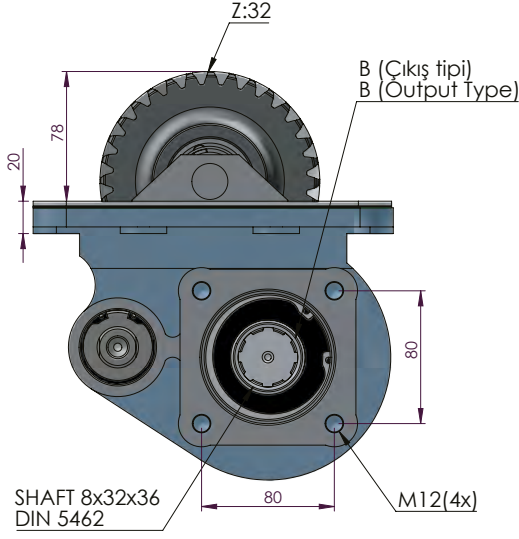

ISUZU

POWER TAKE-OFFS
P.T.O.

| CODE KOD | TYPE TİP (A) | MOUNTING TYPE BAĞLANTI TİPİ (B) | MOUNTING SIDE BAĞLANTI | TORQUE TORK (Kgm / Nm) | POWER GÜC (Hp / Kw) | SPEED DEVİR (RPM) | RATIO ORAN |
|----------------------------|-----------------------|------------------------------------|------------------------------|---|---------------------------|-------------------------|---------------|
| 50620511P0 | PNEUMATIC PNÖMATİK | UNI ADAPTER ADAPTÖRLÜ UNI | SIDE YAN | 45 Kgm 441 Nm | 61 Hp 46 Kw | 2000 RPM | 1:1,28 |
| 50620521P0 | | ISO | | | | | |
| 50620531P0 | | FLANGE ADAPTÖRLÜ FLANŞLI | | | | | |
| 50620541P0 | | SHAFT ADAPTÖRLÜ ŞAFTLI | | | | | |
| GEARBOX / ANA ŞANZIMANLAR | | | | USED VEHICLES / KULLANILAN BAZI ARAÇLAR | | | |
| ISUZU MLD-6Q (8.761-6.720) | | | | F12.240 - F9.210 | | | |