

ISUZU MOZ 79

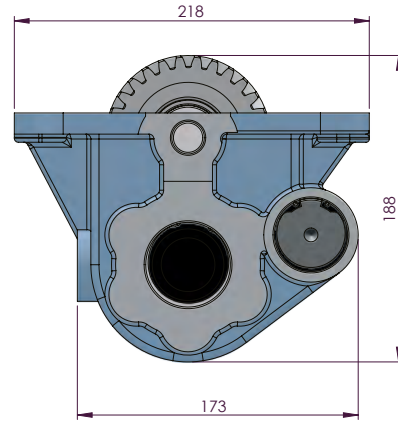
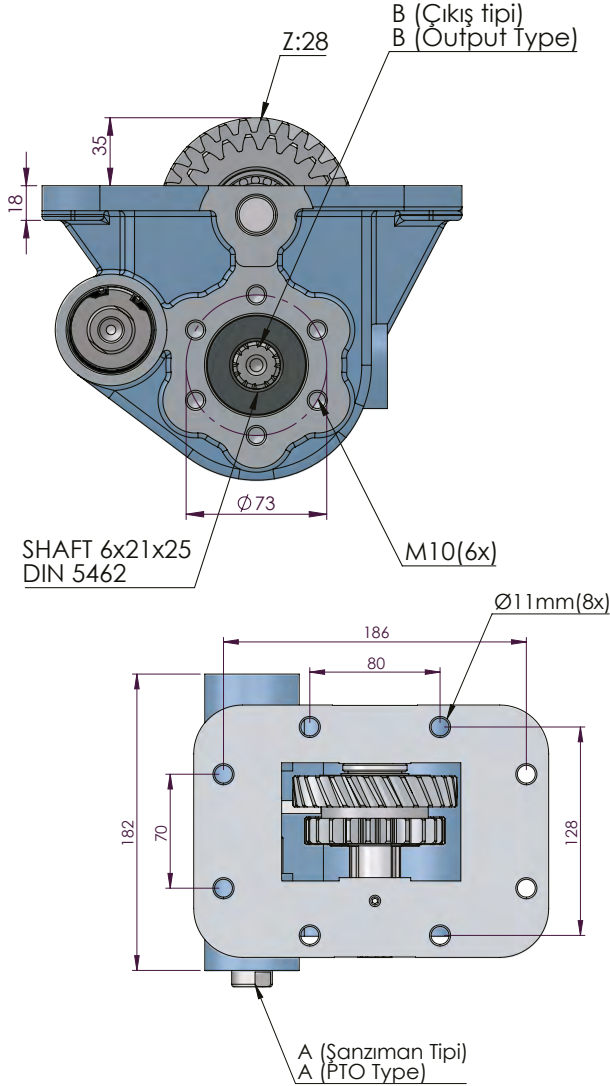

ISUZU

POWER TAKE-OFFS
P.T.O.

CODE KOD	TYPE TİP (A)	MOUNTING TYPE BAĞLANTI TİPİ (B)	MOUNTING SIDE BAĞLANTI	TORQUE TORK (Kgm / Nm)	POWER GÜÇ (Hp / Kw)	SPEED DEVİR (RPM)	RATIO ORAN
50615512M0	MECHANIC MEKANİK	UNI	SIDE YAN	41 Kgm 402 Nm	56 Hp 42 Kw	2000	1:0,9
50615522M0		ISO ADAPTER ADAPTÖRLÜ ISO					
50615532M0		FLANGE FLANŞLI					
50615542M0		SHAFT ŞAFTLI					
50615512P0	PNEUMATIC PNÖMATİK	UNI					
50615522P0		ISO ADAPTER ADAPTÖRLÜ ISO					
50615532P0		FLANGE FLANŞLI					
50615542P0		SHAFT ŞAFTLI					
GEARBOX / ANA ŞANZIMANLAR				USED VEHICLES / KULLANILAN BAZI ARAÇLAR			
MOZ92-MOZ89-MOZ53MOZ-79 /MOZ-95 /M1Z-08 /M1Z-11 /MZZ-6U /MZZ-6W /MZZ-5D / MZZ-6C,6U,6W /MZZ-6P /MZZ-6F /MZZ-6R / MZZ-6S (4,777) / MZZ - 5D (6,369) /MZZ-6N (6,369)				NPR LONG 3D ISUZU / NPR75L (KL5VAYG) / ISUZU FRR 90 / NPR 3D			