

ISUZU MSB 5S

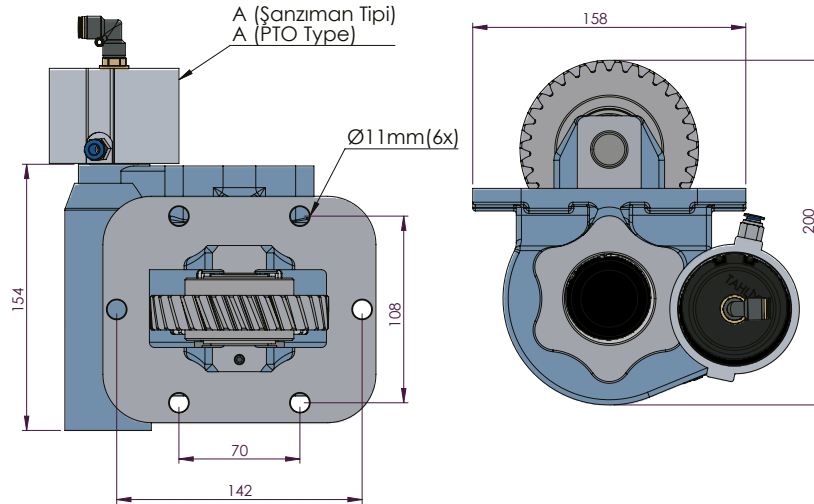
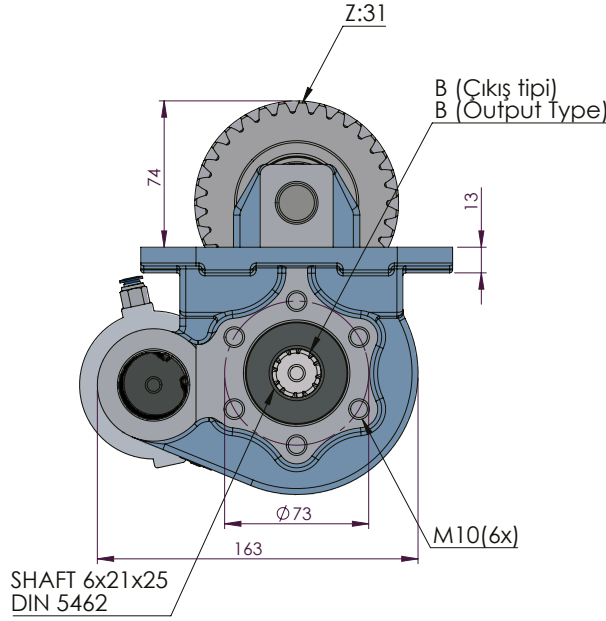

ISUZU

POWER TAKE-OFFS
P.T.O.

CODE KOD	TYPE TİP (A)	MOUNTING TYPE BAĞLANTI TİPİ (B)	MOUNTING SIDE BAĞLANTI	TORQUE TORK (Kgm / Nm)	POWER GÜÇ (Hp / Kw)	SPEED DEVİR (RPM)	RATIO ORAN
50610512M0	MECHANIC MEKANİK	UNI	SIDE YAN	16,6 Kgm 162,8 Nm	14,2 Hp 10,6 Kw	600 RPM	1:1,34
50610522M0		ISO ADAPTER / ADAPTÖRLÜ ISO					
50610532M0		FLANGE / FLANŞLI					
50610542M0		SHAFT / ŞAFTLI					
50610512V0	VACUUM VAKUMLU	UNI					
50610522V0		ISO ADAPTER / ADAPTÖRLÜ ISO					
50610532V0		FLANGE / FLANŞLI					
50610542V0		SHAFT / ŞAFTLI					
50610512P0	PNEUMATIC PNÖMATİK	UNI					
50610522P0		ISO ADAPTER / ADAPTÖRLÜ ISO					
50610532P0		FLANGE / FLANŞLI					
50610542P0		SHAFT / ŞAFTLI					
GEARBOX / ANA ŞANZIMANLAR				USED VEHICLES / KULLANILAN BAZI ARAÇLAR			
MSB - 5S / MSB - 5M / MSB - 5G / MOA 89 / MSB - 5R / MSB - 5N / MSB - 5P / JC521T5H / LC5T88 (5,016-5,037-5,016-5,594) (600 RPM, SAĞ)				NKR 2.8 PTO ISUZU LOW / NKR 55 LOW / NHR 55E / CARRIER 250T / ISUZU FSR/LM 524 / NKR55E2 / NKR55L / BJ1049			