

ISUZU MZW 6P

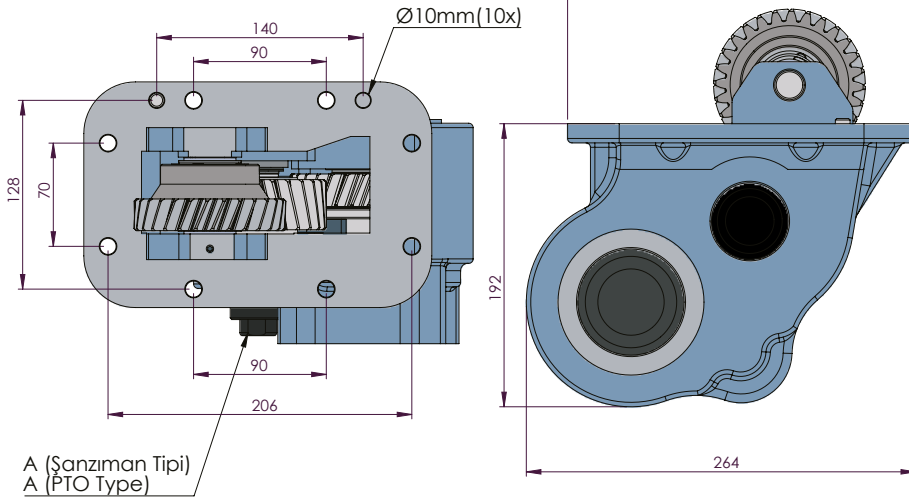
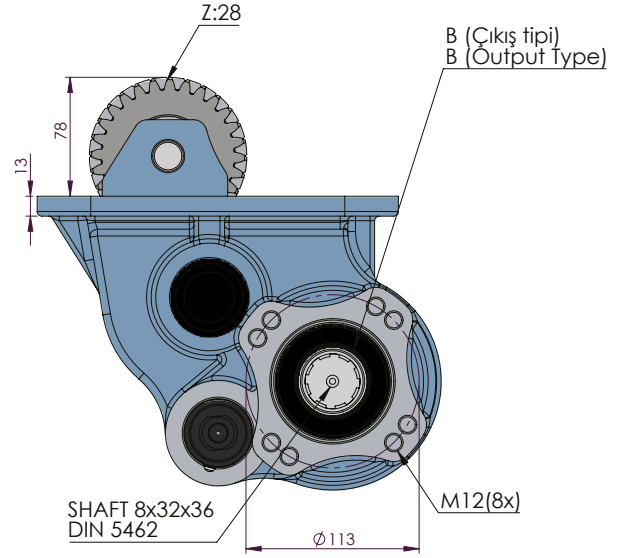

CODE KOD	TYPE TİP (A)	MOUNTING TYPE BAĞLANTI TİPİ (B)	MOUNTING SIDE BAĞLANTI	TORQUE TORK (Kgm / Nm)	POWER GÜÇ (Hp / Kw)	SPEED DEVİR (RPM)	RATIO ORAN
50621512P0	PNEUMATIC PNÖMATİK	UNI ADAPTER ADAPTÖRLÜ UNI	SIDE YAN	44 Kgm 431 Nm	60 Hp 45 Kw	2000 RPM	1:0,95
50621522P0		ISO					
50621532P0		FLANGE ADAPTÖRLÜ FLANŞLI					
50621542P0		SHAFT ADAPTÖRLÜ ŞAFTLI					
GEARBOX / ANA ŞANZIMANLAR				USED VEHICLES / KULLANILAN BAZI ARAÇLAR			
PTO ISUZU MZW 6 P, PTO ISUZU MW 02 B, PTO ISUZU MW00M-T1938805, PTO ISUZU FTR 850 LWB				ISUZU FTR 850 LWB / FRR 210 / FVM-FRR34L-FRR 34N-FSR34N-FTR34P-FTR34Q-FRR 500-FRR 550-FSR 800-FSR 750-FTR 850 FTS 750 4X4 / ISUZU SMOOTHER FRR 500 AMT-FSR 800 AMTFSR 750 CRW AMT-FTR 850 AMT / FVR34UL / GIGA FTR ISUZU ISUZU TORA-ISUZU FORWARD FS			