

IVECO 2828

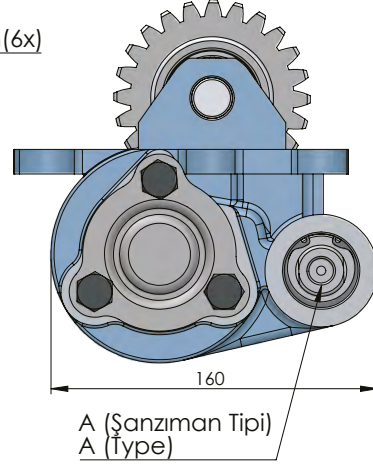
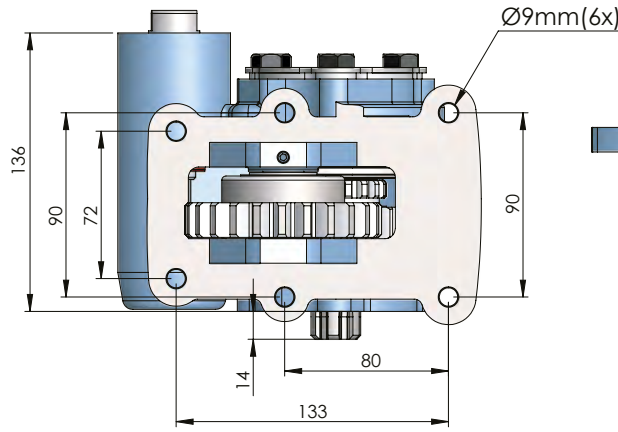
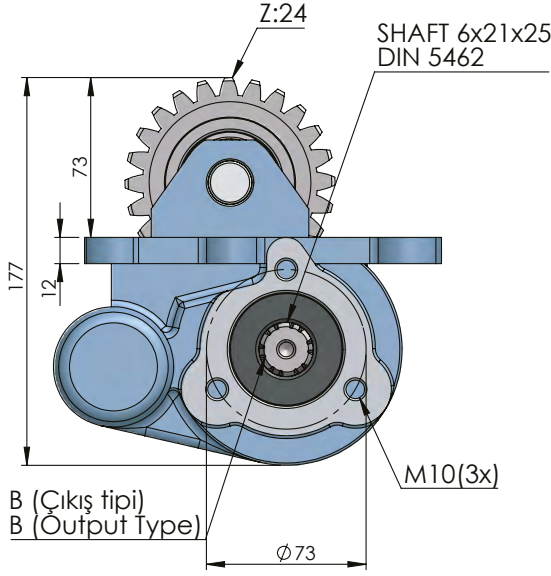

IVECO

POWER TAKE-OFFS
P.T.O.

CODE KOD	TYPE TİP (A)	MOUNTING TYPE BAĞLANTI TİPİ (B)	MOUNTING SIDE BAĞLANTI	TORQUE TORK (Kgm / Nm)	POWER GÜÇ (Hp / Kw)	SPEED DEVİR (RPM)	RATIO ORAN
50816512M0	MECHANIC MEKANİK	UNI	SIDE YAN	15 Kgm 147 Nm	6,2 Hp 4,6 Kw	300 RPM	1:1,26
50816522M0		ISO ADAPTER ADAPTÖRLÜ ISO					
50816532M0		FLANGE FLANŞLI					
50816542M0		SHAFT ŞAFTLI					
50816512P0	PNEUMATIC PNÖMATİK	UNI	SIDE YAN	15 Kgm 147 Nm	6,2 Hp 4,6 Kw	300 RPM	1:1,26
50816522P0		ISO ADAPTER ADAPTÖRLÜ ISO					
5081653P0		FLANGE FLANŞLI					
50816542P0		SHAFT ŞAFTLI					
50816512V0	VACUUM VAKUMLU	UNI	SIDE YAN	15 Kgm 147 Nm	6,2 Hp 4,6 Kw	300 RPM	1:1,26
50816522V0		ISO ADAPTER ADAPTÖRLÜ ISO					
50816532V0		FLANGE FLANŞLI					
50816542V0		SHAFT ŞAFTLI					
GEARBOX / ANA ŞANZIMANLAR				USED VEHICLES / KULLANILAN BAZI ARAÇLAR			
2828.5-2831.5 (300 RPM, SAĞ)				35.9 - 65.9 - 35 NC - 50 NC - 50.9 - 50.11 IVECO - 60.9			

Seçeğinizin pompanın dönüş yönü, P.T.O. dönüş yönü ile ters olmalıdır.
The rotation of the choosen pump has to be opposite with the rotation of P.T.O.

P.T.O. montaj edildikten sonra ana şanzıman yağını tamamlayın.
Fill the oil of the gear box after mounting the P.T.O.

gemmahydraulic.com