

IVECO 2895 DOUBLE GEAR UNI

IVECO 2895 AKTARMALI UNI

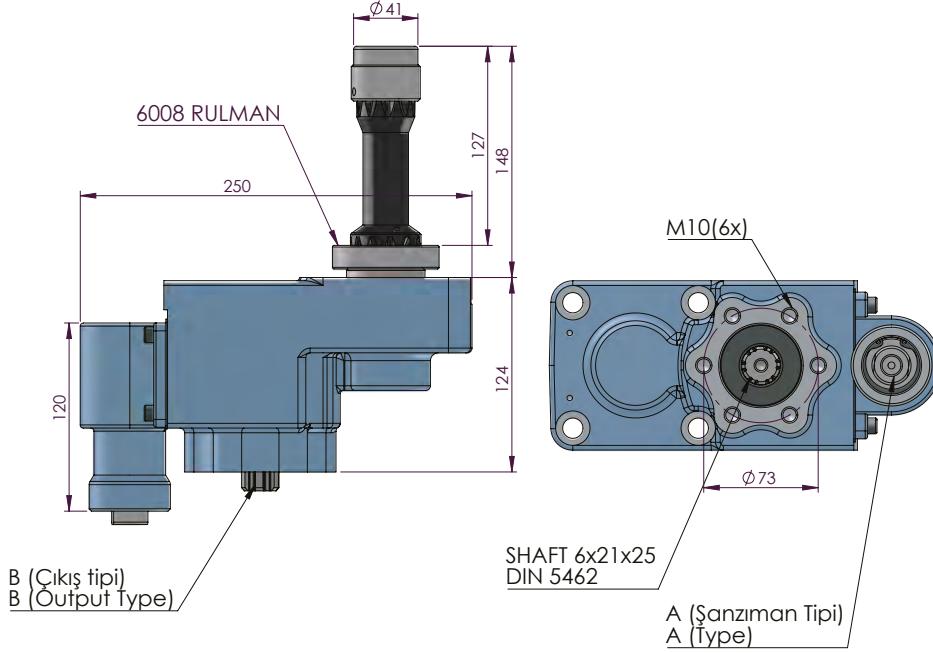
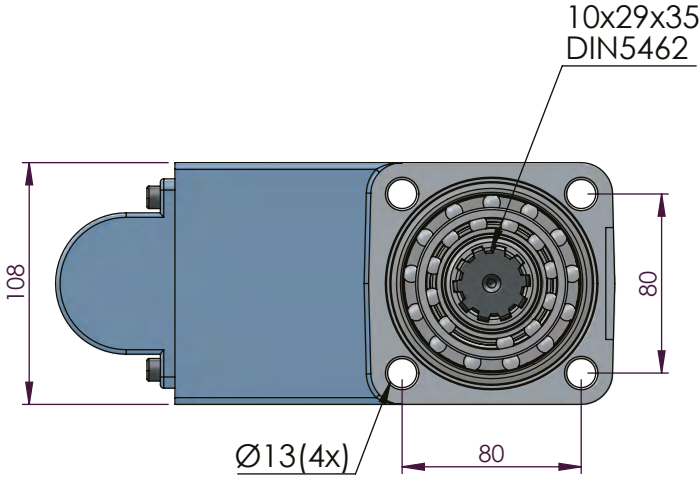

CODE KOD	TYPE TİP (A)	MOUNTING TYPE BAĞLANTI TİPİ (B)	MOUNTING SIDE BAĞLANTI	TORQUE TORK (Kgm / Nm)	POWER GÜÇ (Hp / Kw)	SPEED DEVİR (RPM)	RATIO ORAN
50815311P0	PNEUMATIC PNÖMATİK	UNI	REAR KUYRUK	22,4 Kgm 219,7 Nm	20,8 Hp 15,5 Kw	675 RPM	1:1,12
50815321P0		ISO ADAPTER ADAPTÖRLÜ ISO					
50815331P0		FLANGE FLANŞLI					
50815341P0		SHAFT ŞAFTLI					
GEARBOX / ANA ŞANZIMANLAR				USED VEHICLES / KULLANILAN BAZI ARAÇLAR			
2895.9 (675 RPM, SOL)				120E18-120E23-130E15-130E18-130E23-150E15-150E18-150E23-170E18-170E23-180E21-250E21 -100E18-100E23-100E15-130E15-130E18-250E24-180E28-150E25-190EL25-160E24-180E24-150.17 -175.24-175.27-179.24 / ML160E24-190EL28 / 180E28 EUROARGO IVECO / IVECO MLL180E28			