

KAMAZ

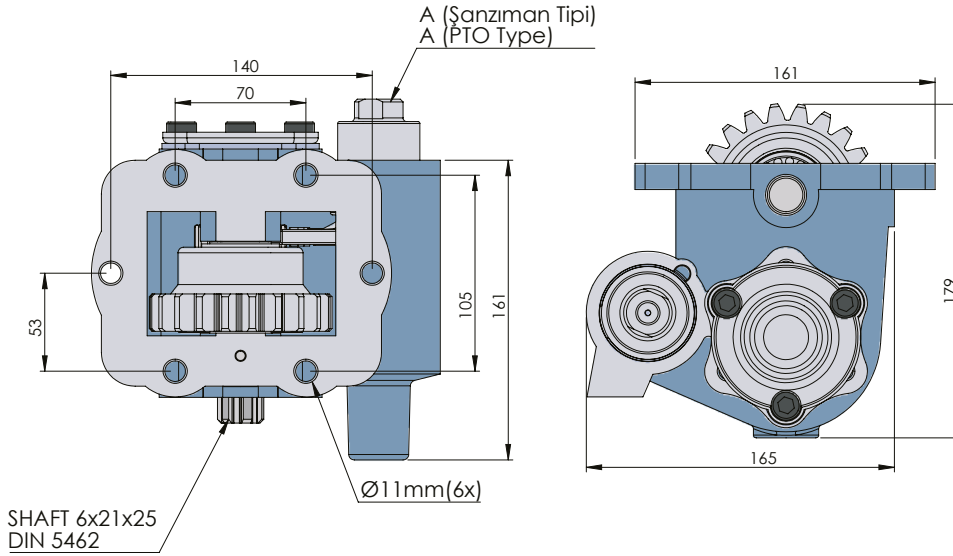
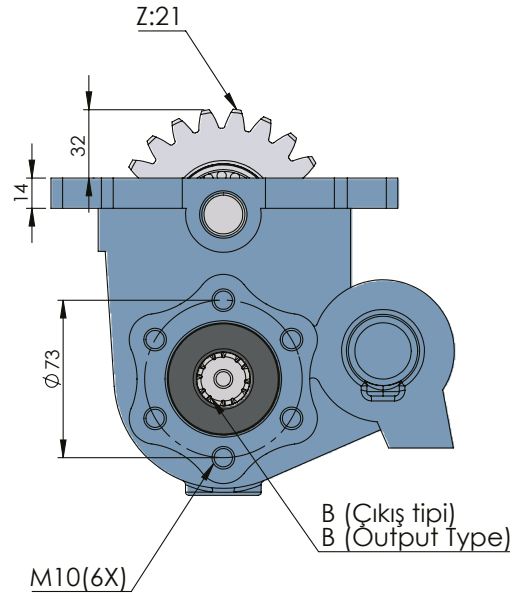

CODE KOD	TYPE TİP (A)	MOUNTING TYPE BAĞLANTI TİPİ (B)	MOUNTING SIDE BAĞLANTI	TORQUE TORK (Kg _m / Nm)	POWER GÜÇ (Hp / Kw)	SPEED DEVİR (RPM)	RATIO ORAN
52011511P0	PNEUMATIC PNÖMATİK	UNI	SIDE YAN	26 Kg _m 260 Nm	36.5 Hp 27,2 Kw	1000 RPM	1:1,5
52011521P0		ISO ADAPTER ADAPTÖRLÜ ISO					
52011531P0		FLANGE FLANŞLI					
52011541P0		SHAFT ŞAFTLI					
GEARBOX / ANA ŞANZIMANLAR				USED VEHICLES / KULLANILAN BAZI ARAÇLAR			
33104 -33106 -1700010/6x4 TURBO 55111 KAMAZ (USSR) - REO - 51301010 KAMAZ 43118 KAMAZ 14 , KAMAZ 15-053 No: 947789 , KAMAZ 15-050 No:866292				JACK-KAMAZ- KAMAZ-154 / 154-053 / 154-050 6x4 TURBO 55111 KAMAZ (USSR) - REO			