

LIAZ 2 DOUBLE GEAR ISO

LIAZ 2 AKTARMALI ISO

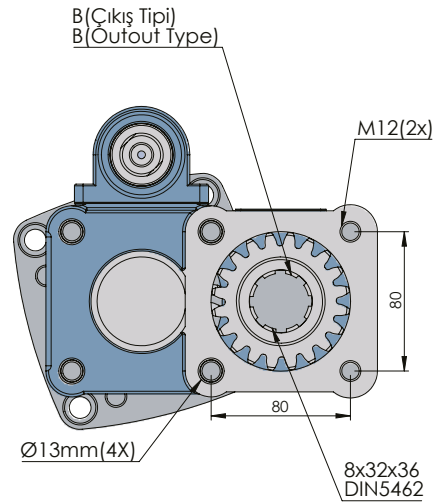
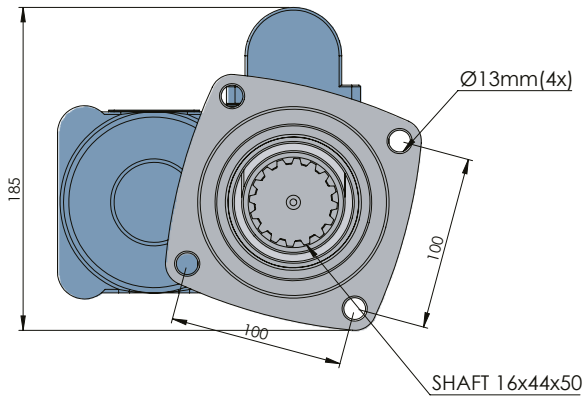
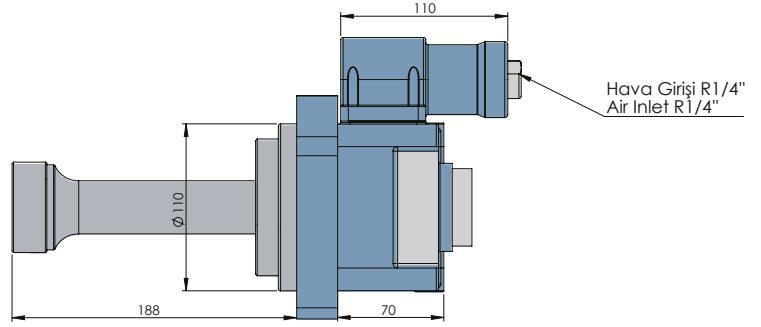

CODE KOD	TYPE TİP (A)	MOUNTING TYPE BAĞLANTI TİPİ (B)	MOUNTING SIDE BAĞLANTI	TORQUE TORK (Kgm / Nm)	POWER GÜÇ (Hp / Kw)	SPEED DEVİR (RPM)	RATIO ORAN
51311411P0	PNEUMATIC PNÖMATİK	UNI ADAPTER ADAPTÖRLÜ UNI	REAR KUYRUK	26,5 Kgm 260 Nm	24,5 Hp 18,3 Kw	675 RPM	1:1,2
51311421P0		ISO					
51311431P0		FLANGE ADAPTÖRLÜ FLANŞLI					
51311441P0		SHAFT ADAPTÖRLÜ ŞAFTLI					
GEARBOX / ANA ŞANZİMANLAR				USED VEHICLES / KULLANILAN BAZI ARAÇLAR			
LIAZ				LIAZ			