

# MACK 1 DM600

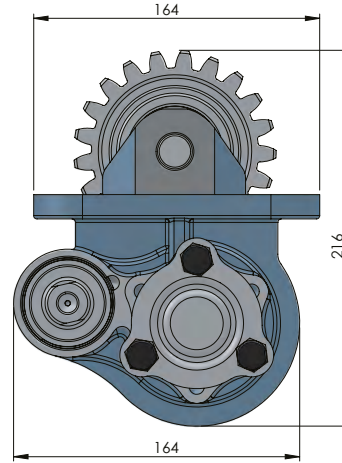
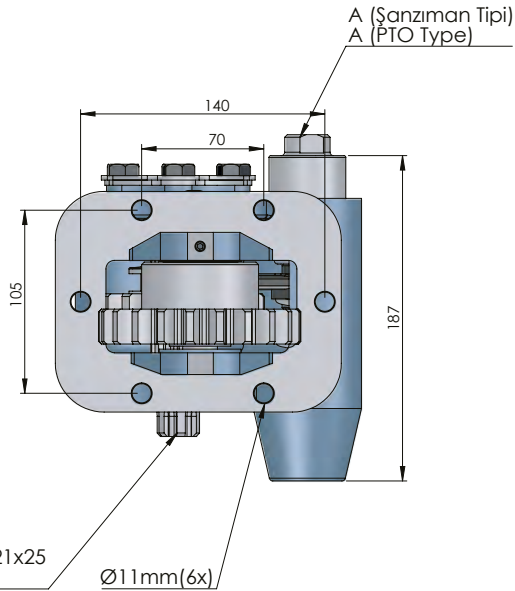
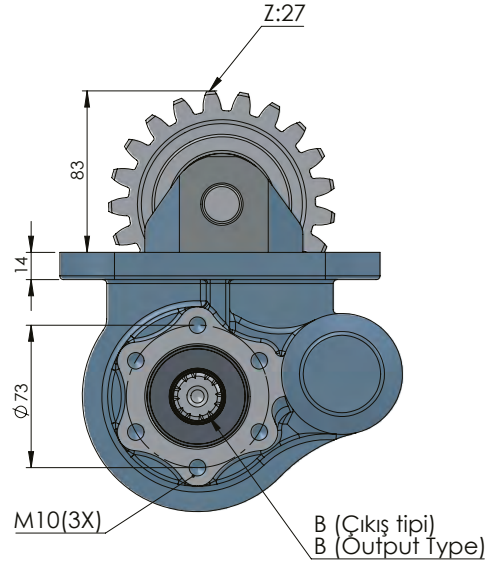

CODE KOD	TYPE TİP (A)	MOUNTING TYPE BAĞLANTI TİPİ (B)	MOUNTING SIDE BAĞLANTI	TORQUE TORK (Kgm / Nm)	POWER GÜÇ (Hp / Kw)	SPEED DEVİR (RPM)	RATIO ORAN
51111512P0	PNEUMATIC PNÖMATİK	UNI	SIDE YAN	25 Kgm 245 Nm	47 Hp 35 Kw	950 RPM	1:1,16
51111522P0		ISO ADAPTER ADAPTÖRLÜ ISO					
51111532P0		FLANGE FLANŞLI					
51111542P0		SHAFT ŞAFTLI					
GEARBOX / ANA ŞANZIMANLAR				USED VEHICLES / KULLANILAN BAZI ARAÇLAR			
DM 600-227589-281KB565-284KB5159A MACK				MACK DM600-DM611 S 6296-MACK 5.08-MACK TRD 722			