

## MERCEDES 352-1 SINGLE GEAR ISO

MERCEDES 352-1 TEK DİŞLİ ISO

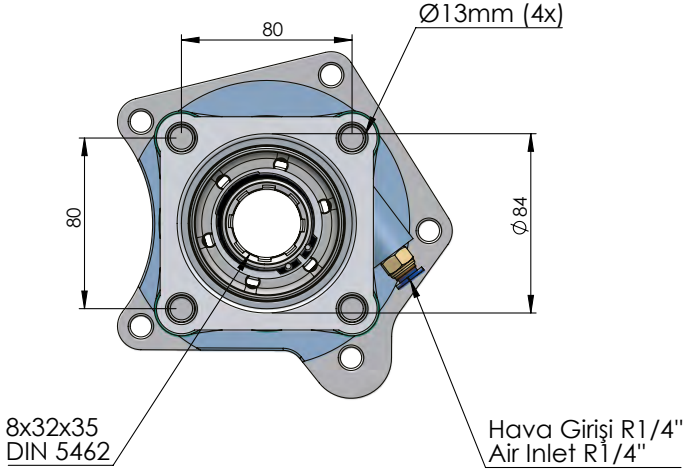

B (Çıkış tipi)  
B (Output type)

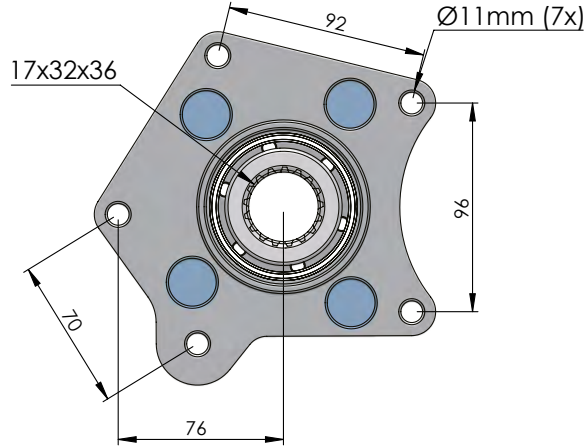
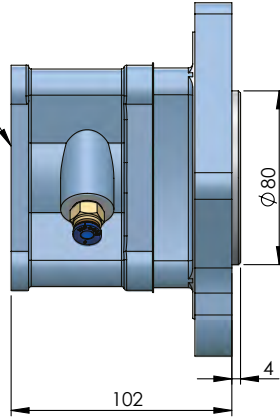

CODE KOD	TYPE TİP (A)	MOUNTING TYPE BAĞLANTI TİPİ (B)	MOUNTING SIDE BAĞLANTI	TORQUE TORK [Kgm / Nm]	POWER GÜÇ [Hp / Kw]	SPEED DEVİR [RPM]	RATIO ORAN
50121312P0	PNEUMATIC PNÖMATİK	UNI ADAPTER ADAPTÖRLÜ UNI	REAR KUYRUK	23 Kgm 255 Nm	16 Hp 12 Kw	500	1:1
50121322P0		ISO					
50121332P0		FLANGE ADAPTÖRLÜ FLANŞLI					
50121342P0		SHAFT ADAPTÖRLÜ ŞAFTLI					
GEARBOX / ANA ŞANZIMANLAR				USED VEHICLES / KULLANILAN BAZI ARAÇLAR			
G3 / 32,36,40,45,50,55,60,61 ( 5/8,98-5/7,508-6/8,5-5/6,106 )				315-352-362-383-609-710-712-809-812-813-814-817-911-913-914-1017-1113-1114-1213-1216- 1318-1414-1618 Mercedes			