

MERCEDES 352-2 DOUBLE GEAR UNI

MERCEDES 352-2 AKTARMALI UNI

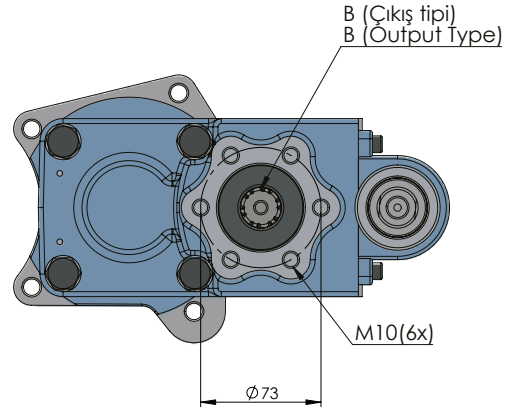
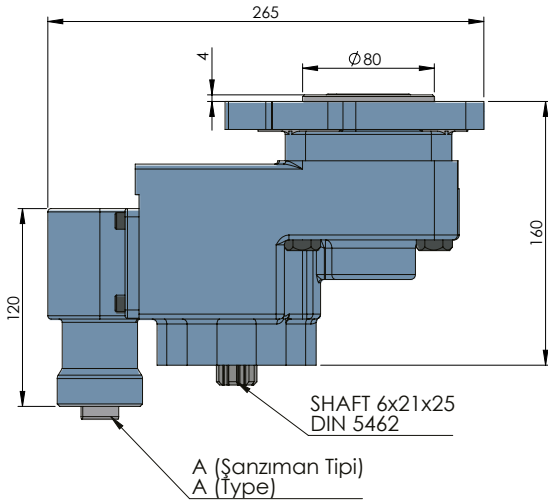
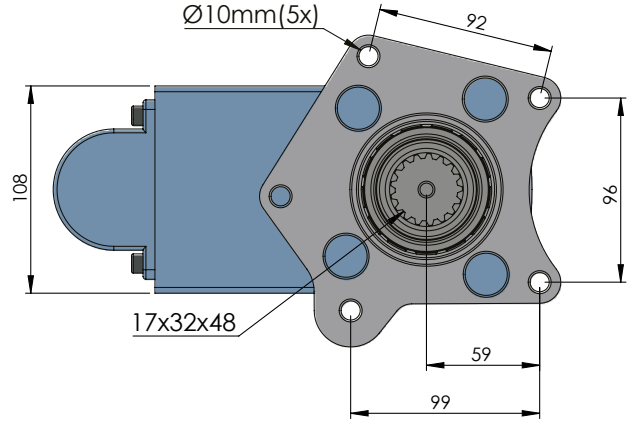

CODE KOD	TYPE TİP (A)	MOUNTING TYPE BAĞLANTI TİPİ (B)	MOUNTING SIDE BAĞLANTI	TORQUE TORK (Kgm / Nm)	POWER GÜÇ (Hp / Kw)	SPEED DEVİR (RPM)	RATIO ORAN
50120311P0	PNEUMATIC PNÖMATİK	UNI	REAR KUYRUK	22,4 Kgm 219,7 Nm	20 Hp 14,9 Kw	650	1:1,12
50120321P0		ISO ADAPTER ADAPTÖRLÜ ISO					
50120331P0		FLANGE FLANŞLI					
50120341P0		SHAFT ŞAFTLI					
GEARBOX / ANA ŞANZIMANLAR				USED VEHICLES / KULLANILAN BAZI ARAÇLAR			
63 / 32,36,40,45,50,55,60,61 (5/8,98-5/7,508-6/8,5-5/6,106)				315-352-362-383-609-710-712-809-812-813-814-817-911-913-914-1017-1113-1114-1213-1216- 1318-1414-1618 Mercedes			