

MERCEDES G100-1 SINGLE GEAR ISO

MERCEDES G100-1 TEK DİŞLİ ISO

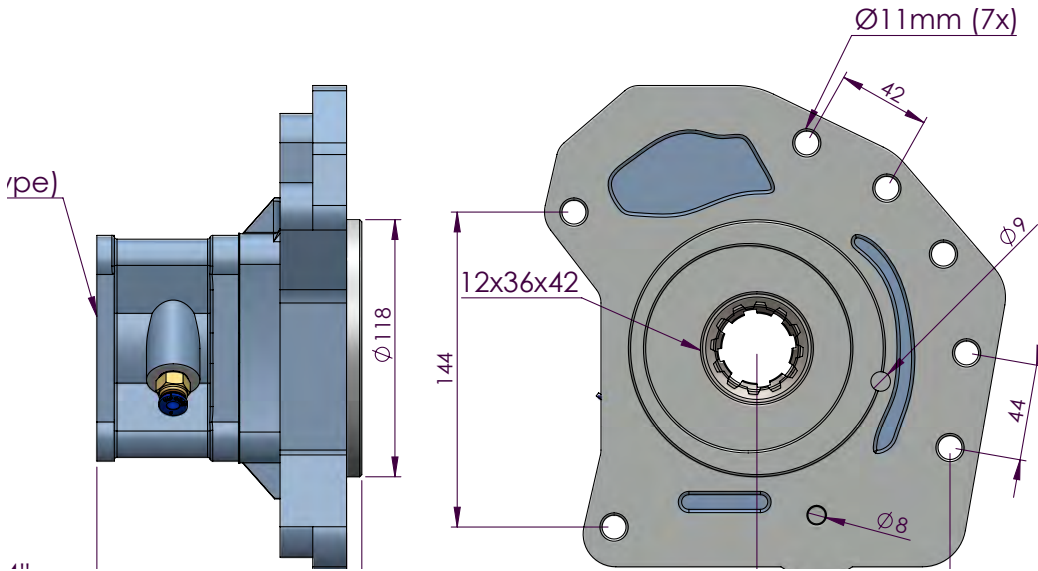
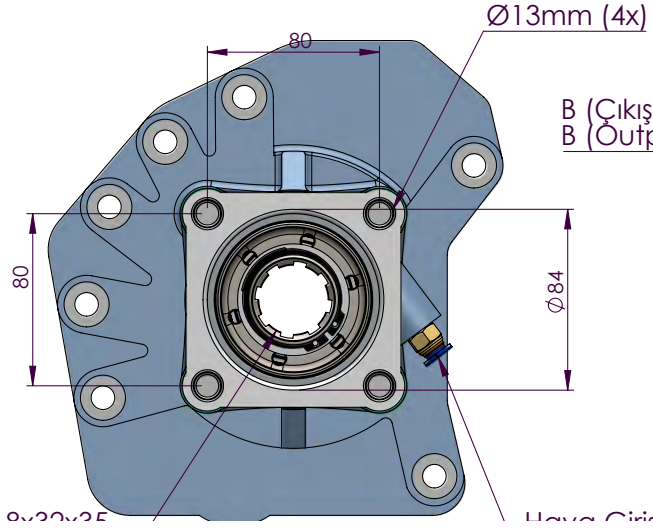

CODE KOD	TYPE TİP (A)	MOUNTING TYPE BAĞLANTI TİPİ (B)	MOUNTING SIDE BAĞLANTI	TORQUE TORK (Kgm / Nm)	POWER GÜÇ (Hp / Kw)	SPEED DEVİR (RPM)	RATIO ORAN
50124312P0	PNEUMATIC PNÖMATİK	UNI ADAPTER ADAPTÖRLÜ UNI	REAR KUYRUK	24 Kgm 235,5 Nm	16 Hp 12 Kw	500	1:1
50124322P0		ISO					
50124332P0		FLANGE ADAPTÖRLÜ FLANŞLI					
50124342P0		SHAFT ADAPTÖRLÜ ŞAFTLI					
GEARBOX / ANA ŞANZİMANLAR				USED VEHICLES / KULLANILAN BAZI ARAÇLAR			
G 100-12 G 100-12 / G 140-8				1528-1823-1828-1924-2523-2528-2623-2628-2832-3224-3228 AXOR / 2632 ACTROS 823-923- 1023-1223-1225-1228-1323-1328-1523-1528-1828-2528-2628 ATEGO			