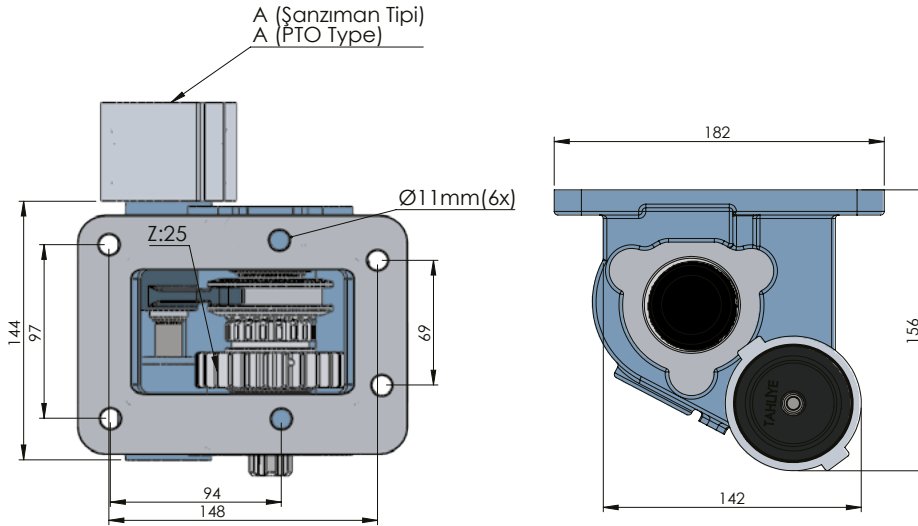
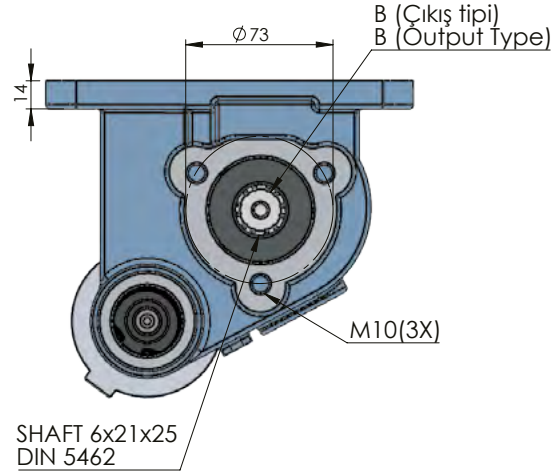

MITSUBISHI M1S5

MITSUBISHI

 POWER TAKE-OFFS
 P.T.O.

CODE KOD	TYPE TİP (A)	MOUNTING TYPE BAĞLANTI TİPİ (B)	MOUNTING SIDE BAĞLANTI	TORQUE TORK (Kg / Nm)	POWER GÜÇ (Hp / Kw)	SPEED DEVİR (RPM)	RATIO ORAN
50710512M0	MECHANIC MEKANİK	UNI	SIDE YAN	18,2Kg 178,5 Nm	9,4 Hp 7 Kw	375 RPM	1:1
50710522M0		ISO ADAPTER / ADAPTÖRLÜ ISO					
50710532M0		FLANGE / FLANŞLI					
50710542M0		SHAFT / ŞAFTLI					
50710512V0	VACUUM VAKUMLU	UNI	SIDE YAN	18,2Kg 178,5 Nm	9,4 Hp 7 Kw	375 RPM	1:1
50710522V0		ISO ADAPTER / ADAPTÖRLÜ ISO					
50710532V0		FLANGE / FLANŞLI					
50710542V0		SHAFT / ŞAFTLI					
GEARBOX / ANA ŞANZIMANLAR				USED VEHICLES / KULLANILAN BAZI ARAÇLAR			
M1S5 - M2S5 - M3S5 (4,444-5,494-5,886-5,181) / DYMO5 V1 (375 RPM, SAĞ)				444-449 CANTER MITSUBISHI(704) / HT 1016698 / 430505H503 / SHERPA INDIA SANZIMANI DYMO5 H 350 / 3F 412 / HD 50-72-77 HYUNDAI / HD 65 / 03R04495 / 03R04499 03R04493 / HD 35 / HT 102T00336 / 519 / 539 / 535 / 649 CANTER			