

MITSUBISHI M015S5

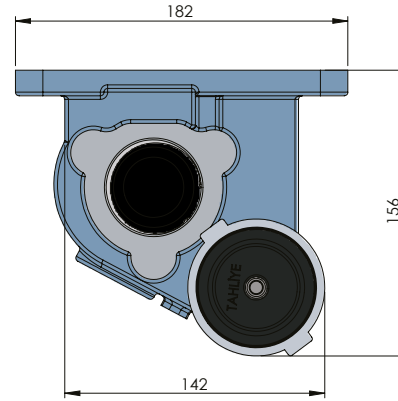
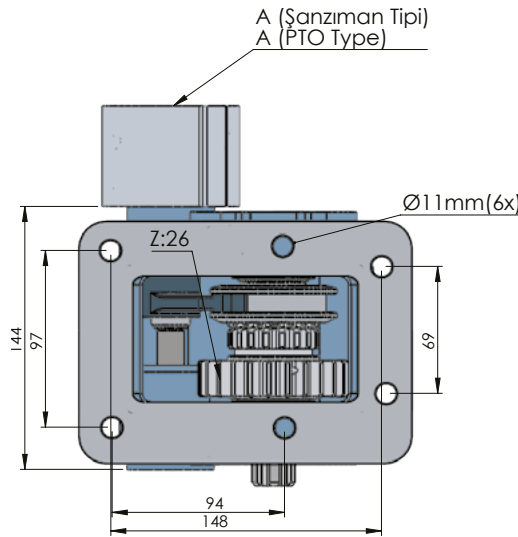
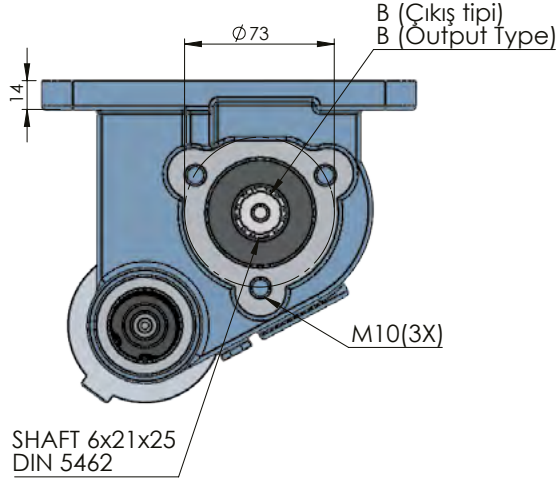

MITSUBISHI

POWER TAKE-OFFS
P.T.O.

CODE KOD	TYPE TİP (A)	MOUNTING TYPE BAĞLANTI TİPİ (B)	MOUNTING SIDE BAĞLANTI	TORQUE TORK (Kg / Nm)	POWER GÜÇ (Hp / Kw)	SPEED DEVİR (RPM)	RATIO ORAN
50712512M0	MECHANIC MEKANİK	UNI	SIDE YAN	24 Kg 235,5 Nm	11,7 Hp 8,7 Kw	375 RPM	1:1
50712522M0		ISO ADAPTER ADAPTÖRLÜ ISO					
50712532M0		FLANGE FLANŞLI					
50712542M0		SHAFT ŞAFTLI					
50712512V0	VACUUM VAKUMLU	UNI	SIDE YAN	24 Kg 235,5 Nm	11,7 Hp 8,7 Kw	375 RPM	1:1
50712522V0		ISO ADAPTER ADAPTÖRLÜ ISO					
50712532V0		FLANGE FLANŞLI					
50712542V0		SHAFT ŞAFTLI					
GEARBOX / ANA ŞANZIMANLAR				USED VEHICLES / KULLANILAN BAZI ARAÇLAR			
M0 15 S 5 (4,733) (375 RPM, SAĞ)				EURO 2 FE71AB / FE 454 / FE 511 / FE 711 MITSUBISHI (733)			