

# MITSUBISHI M025S5

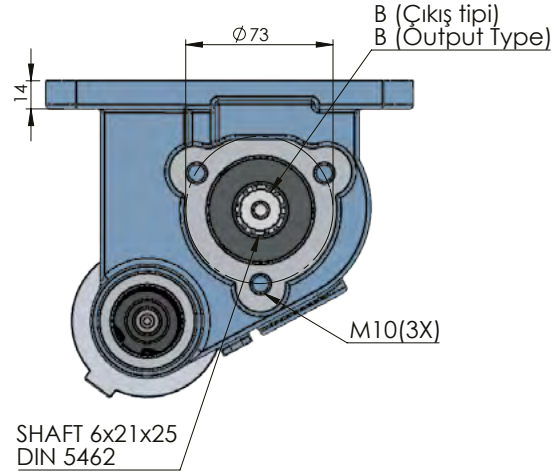

A (Şanzıman Tipi)  
 A (PTO Type)

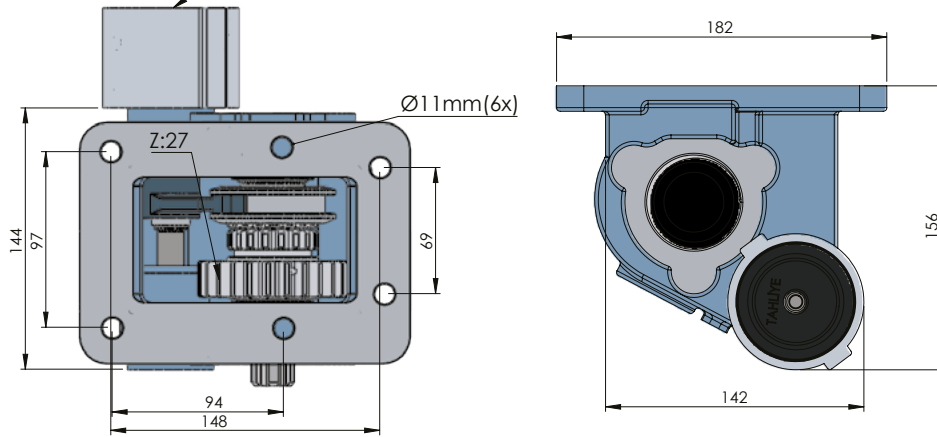

CODE KOD	TYPE TİP (A)	MOUNTING TYPE BAĞLANTI TİPİ (B)	MOUNTING SIDE BAĞLANTI	TORQUE TORK (Kg <sub>m</sub> / Nm)	POWER GÜÇ (Hp / Kw)	SPEED DEVİR (RPM)	RATIO ORAN
50713512M0	MECHANIC MEKANİK	UNI	SIDE YAN	21,1 Kg <sub>m</sub> 207 Nm	10,2 Hp 7,6 Kw	350 RPM	1:1
50713522M0		ISO ADAPTER ADAPTÖRLÜ ISO					
50713532M0		FLANGE FLANŞLI					
50713542M0		SHAFT ŞAFTLI					
50713512V0	VACUUM VAKUMLU	UNI	SIDE YAN	21,1 Kg <sub>m</sub> 207 Nm	10,2 Hp 7,6 Kw	350 RPM	1:1
50713522V0		ISO ADAPTER ADAPTÖRLÜ ISO					
50713532V0		FLANGE FLANŞLI					
50713542V0		SHAFT ŞAFTLI					
GEARBOX / ANA ŞANZIMANLAR				USED VEHICLES / KULLANILAN BAZI ARAÇLAR			
M0 25 S 5 / M0 25 T1 (4,28-4,748-5.181) (350 RPM, SAĞ)				EURO 2 FE83PC / 635 FE - 515 FE - 519 FE - FE 534 - FE 544 - FB 634 - FE 639 C - 839 FE130C1 CANTER 2.0 SUPER LOW MITSUBISHI (739) / FE 84			