

## MITSUBISHI M026S5

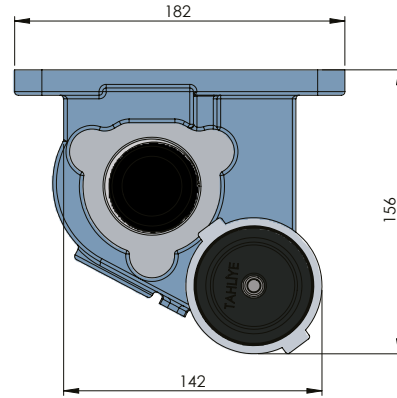
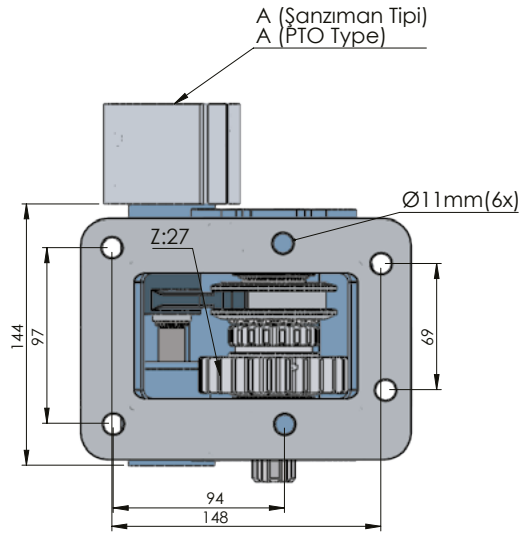
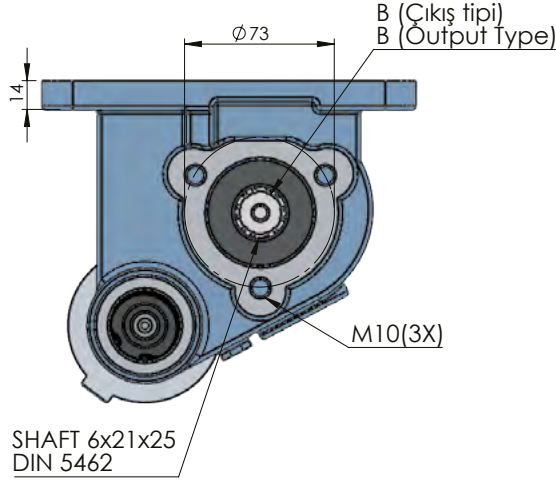

MITSUBISHI

POWER TAKE-OFFS  
P.T.O.

CODE KOD	TYPE TİP (A)	MOUNTING TYPE BAĞLANTI TİPİ (B)	MOUNTING SIDE BAĞLANTI	TORQUE TORK (Kg <sub>m</sub> / Nm)	POWER GÜÇ (Hp / Kw)	SPEED DEVİR (RPM)	RATIO ORAN
50714512M0	MECHANIC MEKANİK	UNI	SIDE YAN	21,1 Kg <sub>m</sub> 207 Nm	10,2 Hp 7,6 Kw	350 RPM	1:1
50714522M0		ISO ADAPTER ADAPTÖRLÜ ISO					
50714532M0		FLANGE FLANŞLI					
50714542M0		SHAFT ŞAFTLI					
50714512V0	VACUUM VAKUMLU	UNI					
50714522V0		ISO ADAPTER ADAPTÖRLÜ ISO					
50714532V0		FLANGE FLANŞLI					
50714542V0		SHAFT ŞAFTLI					
GEARBOX / ANA ŞANZIMANLAR				USED VEHICLES / KULLANILAN BAZI ARAÇLAR			
M0 26 S 5 / 27 S 5 (4,748)				FE 730-FE 839EURO 4 FE71BB / FE73BE / FE83BC			