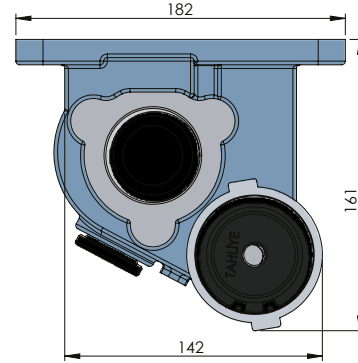
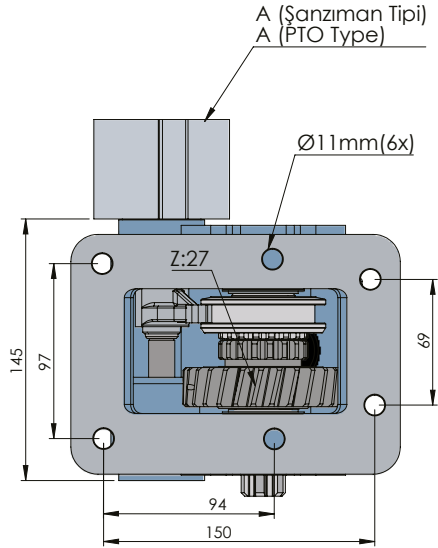
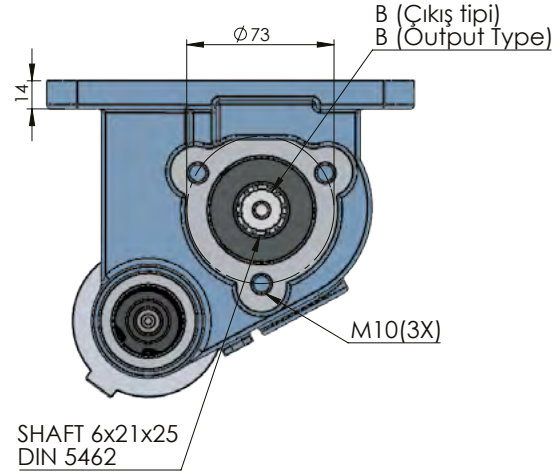

MITSUBISHI M035S5

MITSUBISHI

 POWER TAKE-OFFS
 P.T.O.

CODE KOD	TYPE TİP (A)	MOUNTING TYPE BAĞLANTI TİPİ (B)	MOUNTING SIDE BAĞLANTI	TORQUE TORK (Kgm / Nm)	POWER GÜC (Hp / Kw)	SPEED DEVİR (RPM)	RATIO ORAN
50724512M0	ORIGINAL TYPE ORIJİNAL TİP	UNI	SIDE YAN	24,8 Kgm 243,3 Nm	11,4 Hp 8,5 Kw	440	1:1
50724522M0		ISO ADAPTER / ADAPTÖRLÜ ISO					
50724532M0		FLANGE / FLANŞLI					
50724542M0		SHAFT / ŞAFTLI					
50715512M0	MECHANIC MEKANİK	UNI		21,1 Kgm 207 Nm	10,2 Hp 7,6 Kw	350	
50715522M0		ISO ADAPTER / ADAPTÖRLÜ ISO					
50715532M0		FLANGE / FLANŞLI					
50715542M0		SHAFT / ŞAFTLI					
50715512V0	VACUUM VAKUMLU	UNI					
50715522V0		ISO ADAPTER / ADAPTÖRLÜ ISO					
50715532V0		FLANGE / FLANŞLI					
50715542V0		SHAFT / ŞAFTLI					
GEARBOX / ANA ŞANZIMANLAR				USED VEHICLES / KULLANILAN BAZI ARAÇLAR			
MO 35 S 5 (5,380-5,52) / MO 35 T3 / 35 S 6 / 35V013 (350 RPM, SAĞ)				EURO 2 FE85PE / PG / FE 649 - 659 - FE 859 E MITSUBISHI / FE150C1-150E1- FE150E2 CANTER 2.0T WIDE CAB FG145C1 4X4 CANTER 2.5T-FE150W1 3.5T-150G1 4T-150G2 4.5T (722 -714) HD 65/72 HYUNDAI HYUNDAI DYMOS / 657 CANTER / FE84PE6L			