

MITSUBISHI M036S6

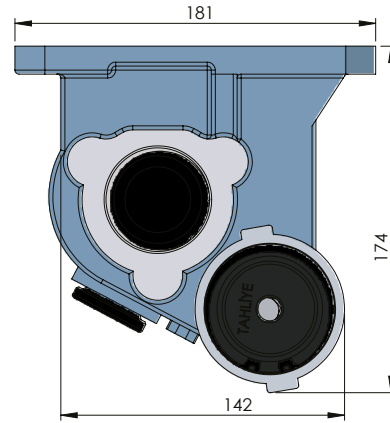
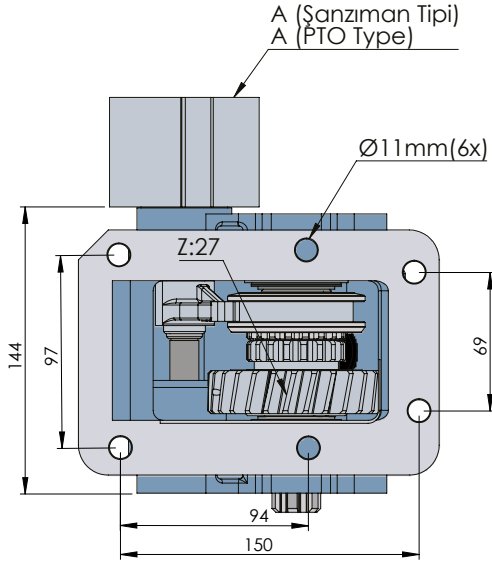
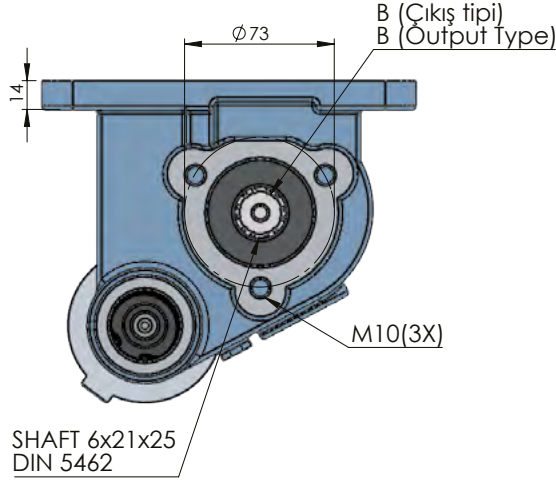

MITSUBISHI

POWER TAKE-OFFS
P.T.O.

CODE KOD	TYPE TİP (A)	MOUNTING TYPE BAĞLANTI TİPİ (B)	MOUNTING SIDE BAĞLANTI	TORQUE TORK (Kg _m / Nm)	POWER GÜÇ (Hp / Kw)	SPEED DEVİR (RPM)	RATIO ORAN
50717512M0	MECHANIC MEKANİK	UNI	SIDE YAN	22.8 Kg _m 223 Nm	31 Hp 23.3 Kw	500 RPM	1:1
50717522M0		ISO ADAPTER ADAPTÖRLÜ ISO					
50717532M0		FLANGE FLANŞLI					
50717542M0		SHAFT ŞAFTLI					
50717512V0	VACUUM VAKUMLU	UNI	SIDE YAN	22.8 Kg _m 223 Nm	31 Hp 23.3 Kw	500 RPM	1:1
50717522V0		ISO ADAPTER ADAPTÖRLÜ ISO					
50717532V0		FLANGE FLANŞLI					
50717542V0		SHAFT ŞAFTLI					
GEARBOX / ANA ŞANZİMANLAR				USED VEHICLES / KULLANILAN BAZI ARAÇLAR			
M0 36 S 6 (5,400) / 36 S 5 / 36 A 6				FE 859 G EURO 4 FE85BE / FE85BG / 7C15			