

MITSUBISHI M038S5

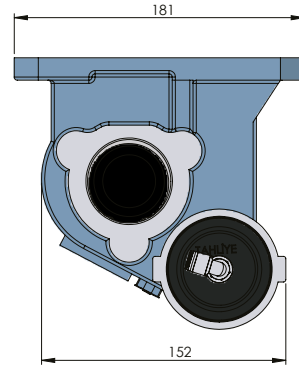
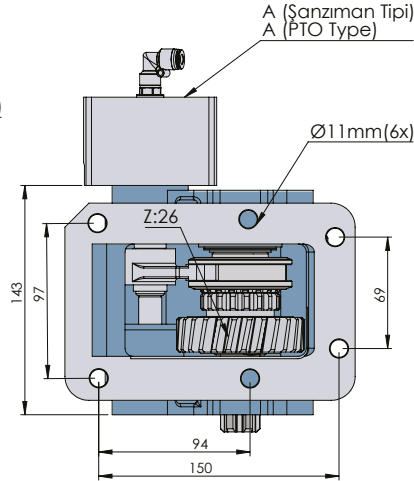
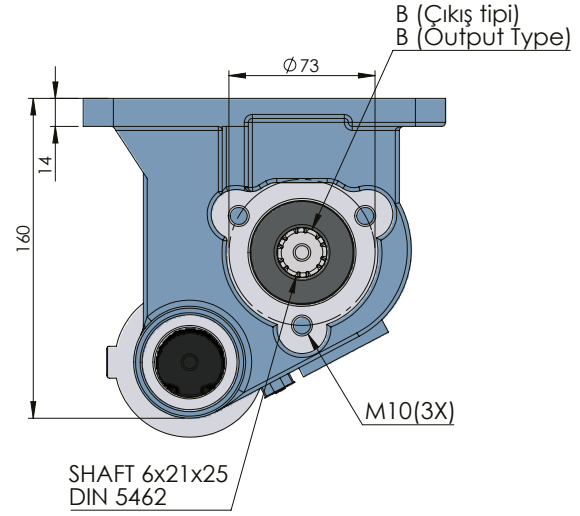

MITSUBISHI

POWER TAKE-OFFS
P.T.O.

CODE KOD	TYPE TİP (A)	MOUNTING TYPE BAĞLANTI TİPİ (B)	MOUNTING SIDE BAĞLANTI	TORQUE TORK (Kg _m / Nm)	POWER GÜÇ (Hp / Kw)	SPEED DEVİR (RPM)	RATIO ORAN
50719512M0	MECHANIC MEKANİK	UNI	SIDE YAN	18.35 Kg _m 180 Nm	21.75 Hp 16 Kw	450 RPM	1:1
50719522M0		ISO ADAPTER / ADAPTÖRLÜ ISO					
50719532M0		FLANGE / FLANŞLI					
50719542M0		SHAFT / ŞAFTLI					
50719512V0	VACUUM VAKUMLU	UNI					
50719522V0		ISO ADAPTER / ADAPTÖRLÜ ISO					
50719532V0		FLANGE / FLANŞLI					
50719542V0		SHAFT / ŞAFTLI					
50719512V1	VACUUM WITH SWITCH VAKUMLU MÜŞÜRLÜ	UNI					
50719522V1		ISO ADAPTER / ADAPTÖRLÜ ISO					
50719532V1		FLANGE / FLANŞLI					
50719542V1		SHAFT / ŞAFTLI					
GEARBOX / ANA ŞANZIMANLAR				USED VEHICLES / KULLANILAN BAZI ARAÇLAR			
M0 38 S5- M0 38 S 6				EURO 5 TF A35L DUONIC / TF B35 DUONIC / TF B75 DUONIC / TF B75L DUONIC / 3C13 / 7C15 / 6C18 / FE 125 / FEC52S FG 4X4 / FGB72S / FE 160 / FEC72S / FEC72W / FE 180 / FEC92S / 515 / 516 / 715 / 815 CANTER CANTER 516-2.0T FEA45C2/2471-MIT-Canter-2.0T-FEB45C2E2nt2/ 4.0TFEW60-75E2/4.5TFEW82G2/2.0TFEW45E2 CANTER 413 / CANTER 515 / CANTER 615 / CANTER 715 / CANTER 815 / CANTER 918 / B35L / B75L EURO 5 FEA21EL3SA21 / FEB21CL3SA22 / FEB91EL3SA23 / FEB91GL3SA23 / FEB91EL3SA29			