

MITSUBISHI M050S6

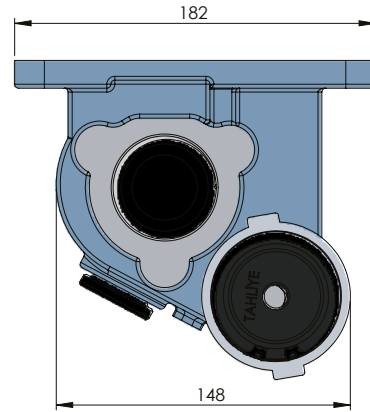
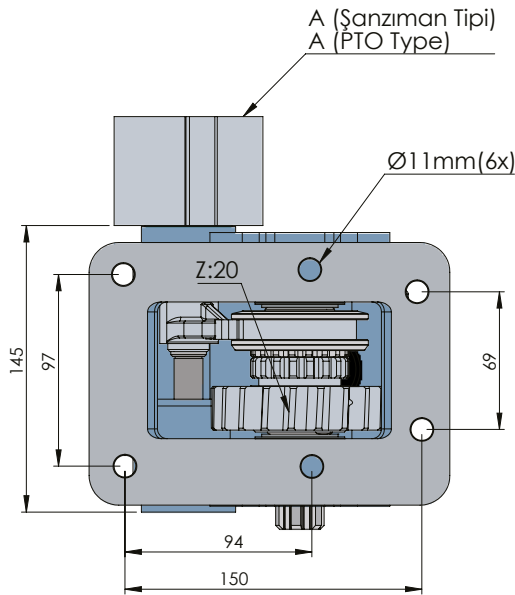
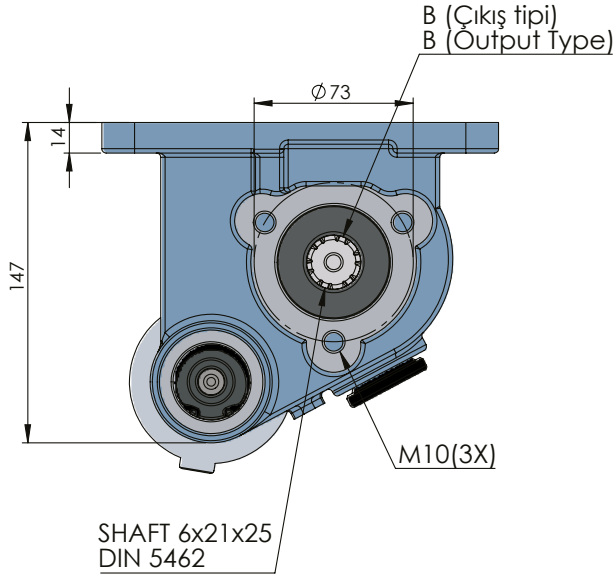

MITSUBISHI

POWER TAKE-OFFS
P.T.O.

CODE KOD	TYPE TİP (A)	MOUNTING TYPE BAĞLANTI TİPİ (B)	MOUNTING SIDE BAĞLANTI	TORQUE TORK (Kg _m / Nm)	POWER GÜÇ (Hp / Kw)	SPEED DEVİR (RPM)	RATIO ORAN
50720512M0	MECHANIC MEKANİK	UNI	SIDE YAN	20 Kg _m 200 Nm	28 Hp 21 Kw	750 RPM	1:1
50720522M0		ISO ADAPTER / ADAPTÖRLÜ ISO					
50720532M0		FLANGE / FLANŞLI					
50720542M0		SHAFT / ŞAFTLI					
50720512V0	VACUUM VAKUMLU	UNI	SIDE YAN	20 Kg _m 200 Nm	28 Hp 21 Kw	750 RPM	1:1
50720522V0		ISO ADAPTER / ADAPTÖRLÜ ISO					
50720532V0		FLANGE / FLANŞLI					
50720542V0		SHAFT / ŞAFTLI					
GEARBOX / ANA ŞANZIMANLAR				USED VEHICLES / KULLANILAN BAZI ARAÇLAR			
M0 50 S 6				FH 215 DRAGON MITSUBISHI / 500 HYUNDAI(802) / FK 750			