

MITSUBISHI M060S5

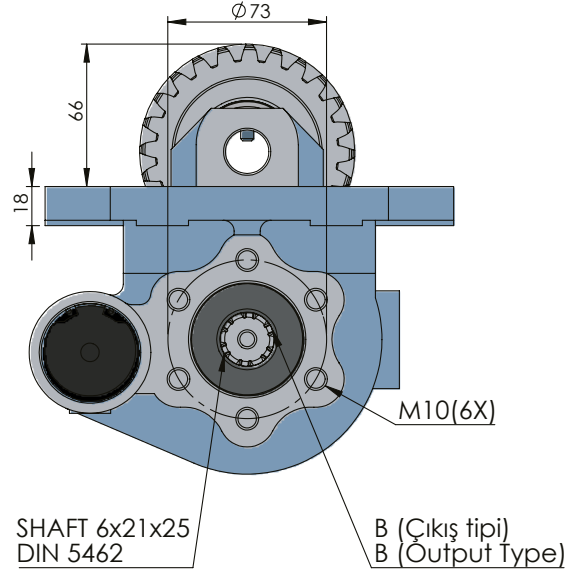

A (Şanzıman Tipi)
A (PTO Type)

Ø11mm(6x)

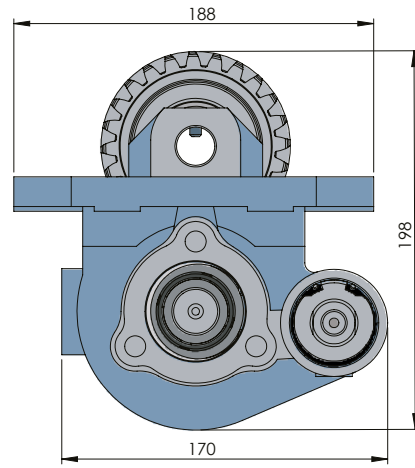
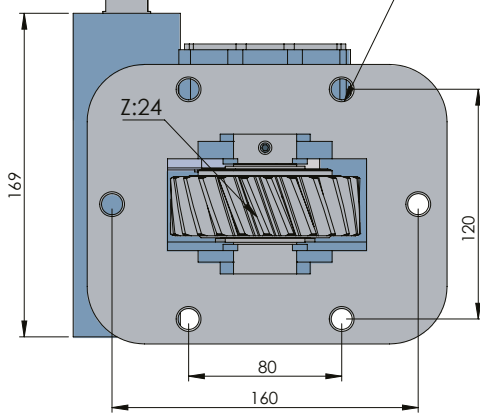

MITSUBISHI

POWER TAKE-OFFS
P.T.O.

CODE KOD	TYPE TİP (A)	MOUNTING TYPE BAĞLANTI TİPİ (B)	MOUNTING SIDE BAĞLANTI	TORQUE TORK (Kgm / Nm)	POWER GÜÇ (Hp / Kw)	SPEED DEVİR (RPM)	RATIO ORAN
50721512M0	MECHANIC MEKANİK	UNI	SIDE YAN	24.3 Kgm 238,5 Nm	25 Kw 33,5 Hp	550 RPM	1:1.15
50721522M0		ISO ADAPTER ADAPTÖRLÜ ISO					
50721532M0		FLANGE FLANŞLI					
50721542M0		SHAFT ŞAFTLI					
50721512P0	PNEUMATIC PNÖMATİK	UNI	SIDE YAN	24.3 Kgm 238,5 Nm	25 Kw 33,5 Hp	550 RPM	1:1.15
50721522P0		ISO ADAPTER ADAPTÖRLÜ ISO					
50721532P0		FLANGE FLANŞLI					
50721542P0		SHAFT ŞAFTLI					
GEARBOX / ANA ŞANZIMANLAR				USED VEHICLES / KULLANILAN BAZI ARAÇLAR			
MO 60S5 / 50S5 / 50S6 (Z=35) (6,748 - 6,875) MO 50S5 A149 ME638314 (6,875 / 1,000)				FIAT IVECO / 65.15-79.13-79.14-80.14 IVECO / 65.12-79.12-95.14-100.13-109.14-135.14 ZETA IVECO 79.13-79.14-65.15-100.13-100.16-135.14 IVECO			