

NISSAN UD 70-90

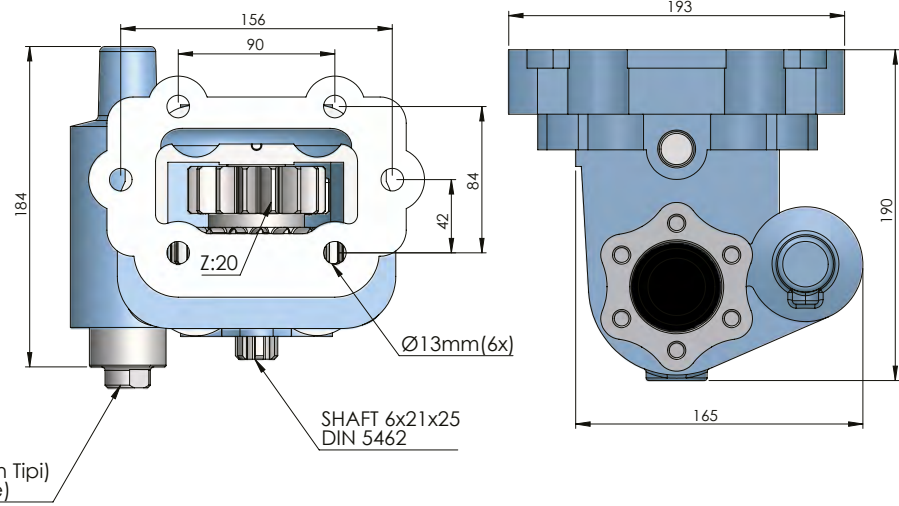
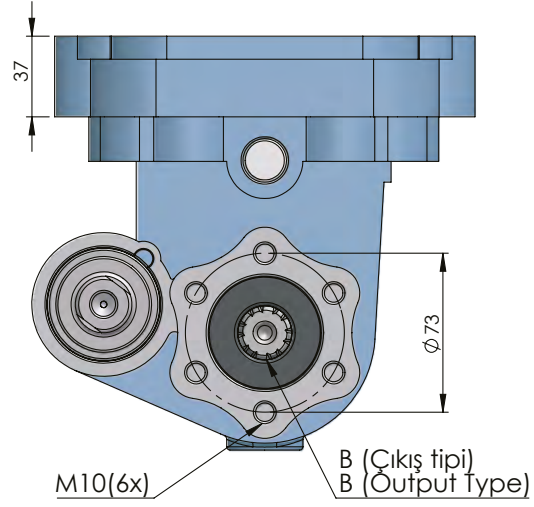

NISSAN

 POWER TAKE-OFFS
 P.T.O.

CODE KOD	TYPE TİP (A)	MOUNTING TYPE BAĞLANTI TİPİ (B)	MOUNTING SIDE BAĞLANTI	TORQUE TORK (Kg _m / Nm)	POWER GÜÇ (Hp / Kw)	SPEED DEVİR (RPM)	RATIO ORAN
51711512P0	PNEUMATIC PNÖMATİK	UNI	SIDE YAN	48 Kg _m 475 Nm	34,5 Hp 25,7 Kw	550 RPM	1:1,07
51711522P0		ISO ADAPTER ADAPTÖRLÜ ISO					
51711532P0		FLANGE FLANŞLI					
51711542P0		SHAFT ŞAFTLI					
GEARBOX / ANA ŞANZIMANLAR				USED VEHICLES / KULLANILAN BAZI ARAÇLAR			
MLS 61 A - B / MLS 62 A / MLS 62 B / MLS 63 B (7,173-6,718)				NISSAN UD70-UD9 0NISSAN PKB214 4X2 / Nissan Diesel Motor Model FE6TA-21/NISSAN DIESEL CKA 87 H / MKD 210 / UD90 / NISSAN UD183HT PKB214/216 PKC211MHRN			