

RENAULT B9-B18

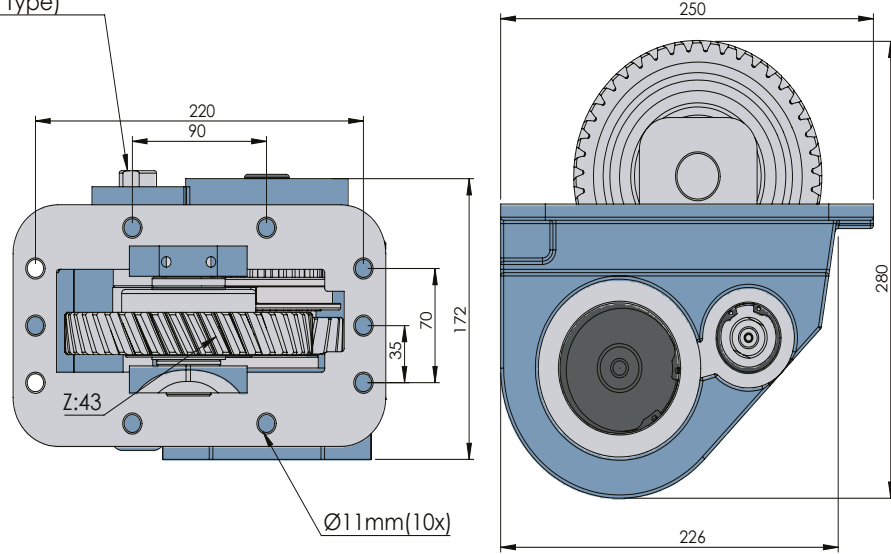
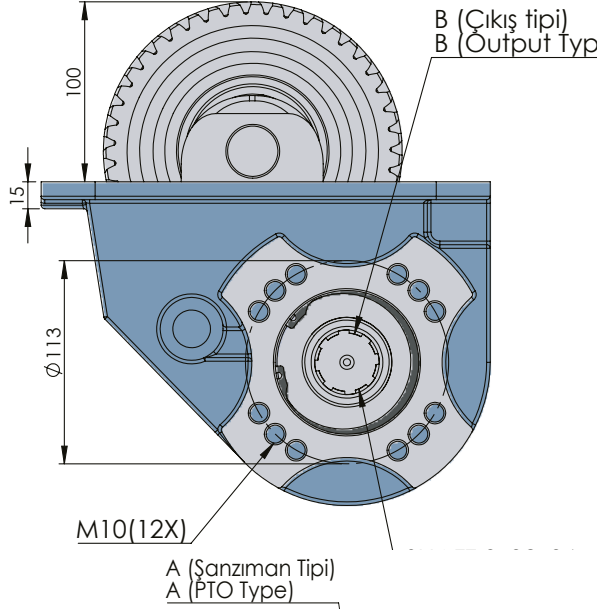

CODE KOD	TYPE TİP (A)	MOUNTING TYPE BAĞLANTI TİPİ (B)	MOUNTING SIDE BAĞLANTI	TORQUE TORK (Kg _m / Nm)	POWER GÜÇ (Hp / Kw)	SPEED DEVİR (RPM)	RATIO ORAN
51810512P0	PNEUMATIC PNÖMATİK	UNI ADAPTER ADAPTÖRLÜ UNI	SIDE YAN	18,2 Kg _m 178,5 Nm	15 Hp 11,2 Kw	750 RPM	1:1,7
51810522P0		ISO					
51810532P0		FLANGE ADAPTÖRLÜ FLANŞLI					
51810542P0		SHAFT ADAPTÖRLÜ ŞAFTLI					
GEARBOX / ANA ŞANZIMANLAR				USED VEHICLES / KULLANILAN BAZI ARAÇLAR			
B9 / B18 / B18200 L 42 B9-150				RENAULT (R.V.I) G340TI MAXTER 280-340-385-400 PREMIUM 430-470 MAGNUM INTEGRAL			