

SCANIA GR801

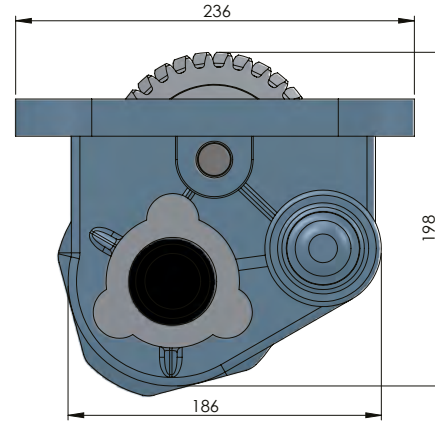
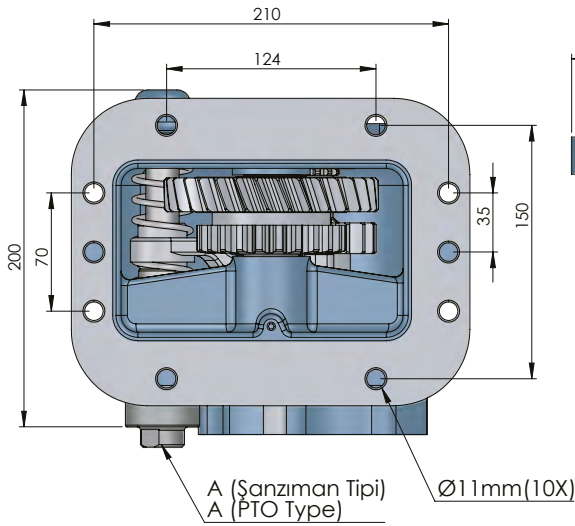
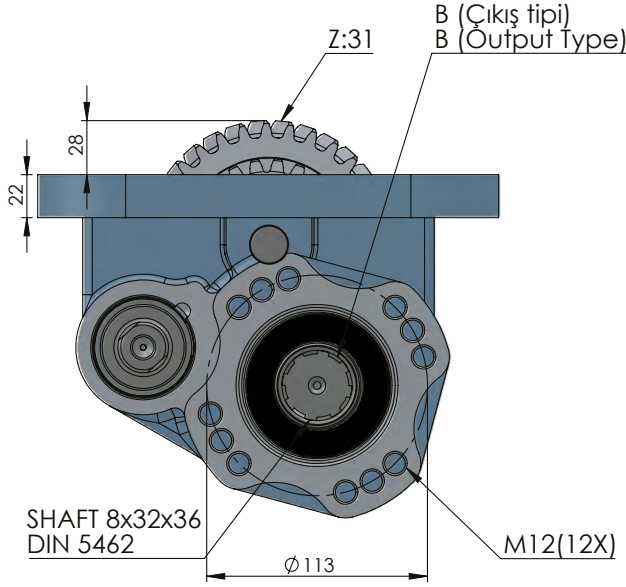

CODE KOD	TYPE TİP (A)	MOUNTING TYPE BAĞLANTI TİPİ (B)	MOUNTING SIDE BAĞLANTI	TORQUE TORK (Kgm / Nm)	POWER GÜÇ (Hp / Kw)	SPEED DEVİR (RPM)	RATIO ORAN
50318512P0	PNEUMATIC PNÖMATİK	UNI ADAPTER ADAPTÖRLÜ UNI	SIDE YAN	34 Kgm 342 Nm	28 Hp 21 Kw	750 RPM	1:1,7
50318522P0		ISO					
50318532P0		FLANGE ADAPTÖRLÜ FLANŞLI					
50318542P0		SHAFT ADAPTÖRLÜ ŞAFTLI					
GEARBOX / ANA ŞANZIMANLAR				USED VEHICLES / KULLANILAN BAZI ARAÇLAR			
GR 801				R94 - 94 -220 -94-260 - 110H - P93 - P94DB - HP 210 - HP220 SCANIA			