

SCANIA GR880

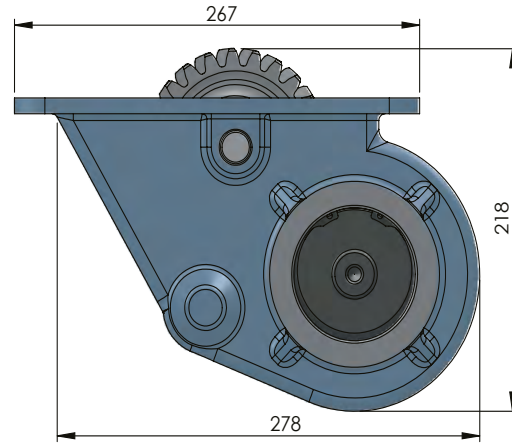
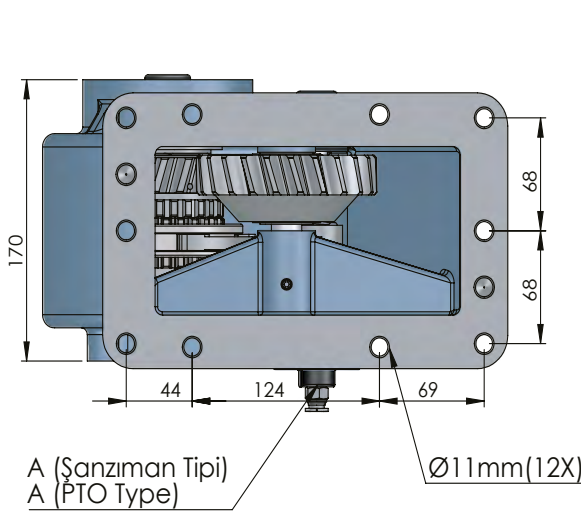
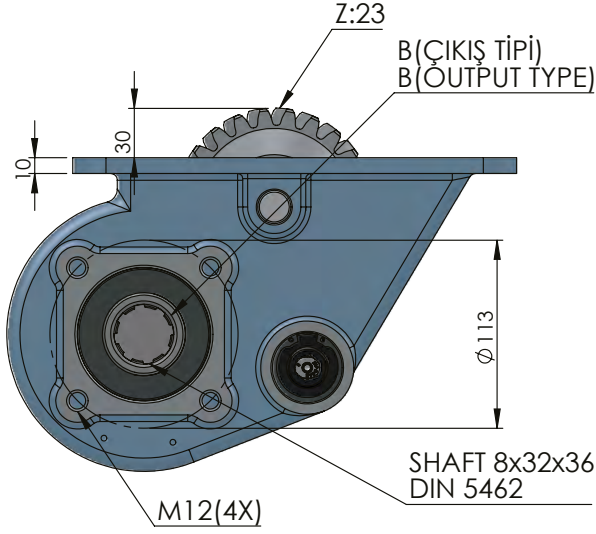

CODE KOD	TYPE TİP (A)	MOUNTING TYPE BAĞLANTI TİPİ (B)	MOUNTING SIDE BAĞLANTI	TORQUE TORK (Kgm / Nm)	POWER GÜÇ (Hp / Kw)	SPEED DEVİR (RPM)	RATIO ORAN
50317512P0	PNEUMATIC PNÖMATİK	UNI ADAPTER ADAPTÖRLÜ UNI	SIDE YAN	21.4 Kgm 210 Nm	30 Hp 22 Kw	1000 RPM	1:1
50317522P0		ISO					
50317532P0		FLANGE ADAPTÖRLÜ FLANŞLI					
50317542P0		SHAFT ADAPTÖRLÜ ŞAFTLI					
GEARBOX / ANA ŞANZIMANLAR				USED VEHICLES / KULLANILAN BAZI ARAÇLAR			
GR 880 - GRH 880				P92 - 93 - 111 - 112C - 113R - 114H - 142M - 144L - 93H 280 - R113M PTO SCANIA P 113M - P114 GA 380 - 114 P - 124 R - 113P - 114R - 113H 360			