

## SCANIA GR900 ISO

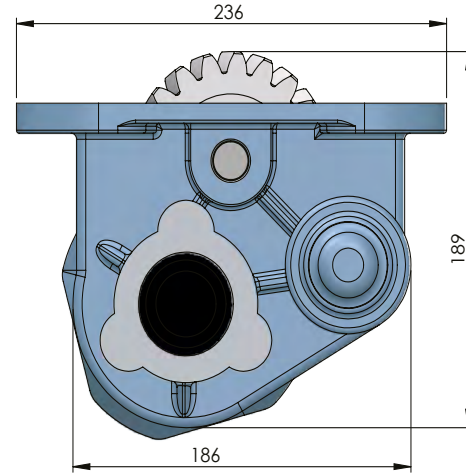
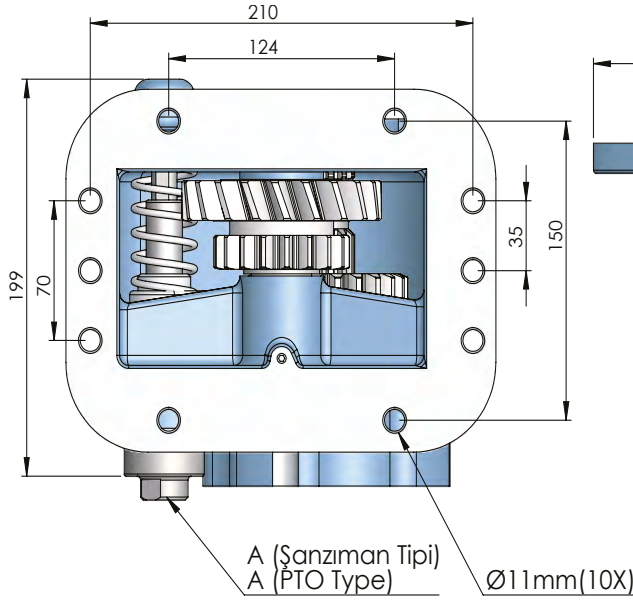
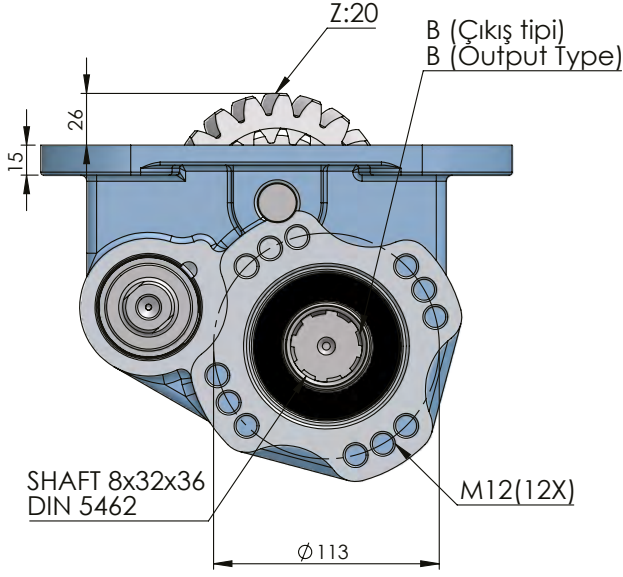

CODE KOD	TYPE TİP (A)	MOUNTING TYPE BAĞLANTI TİPİ (B)	MOUNTING SIDE BAĞLANTI	TORQUE TORK [Kgm / Nm]	POWER GÜÇ [Hp / Kw]	SPEED DEVİR [RPM]	RATIO ORAN
50330512P0	PNEUMATIC PNÖMATİK	UNI ADAPTER ADAPTÖRLÜ UNI	SIDE YAN	"25 Kgm 245 Nm"	"45.3 Hp 33.8 Kw"	1065 Rpm	01:00,8
50330522P0		ISO					
50330532P0		FLANGE ADAPTÖRLÜ FLANŞLI					
50330542P0		SHAFT ADAPTÖRLÜ ŞAFTLI					
GEARBOX / ANA ŞANZIMANLAR				USED VEHICLES / KULLANILAN BAZI ARAÇLAR			
GR 900/ GRH 900 (1065 rpm, SAĞ)				94 C 310-124 C 360-R 124 GB 360-124 G 360-143 H 450 CV-143M 400 CV-260H-143H/P 113M- P114-GA 380-114P-124R-113P-114R-113H 360			