

SCANIA GS771

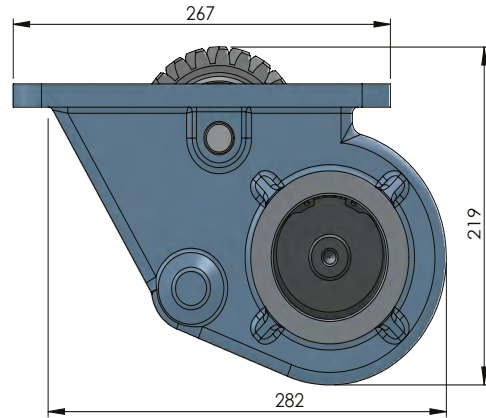
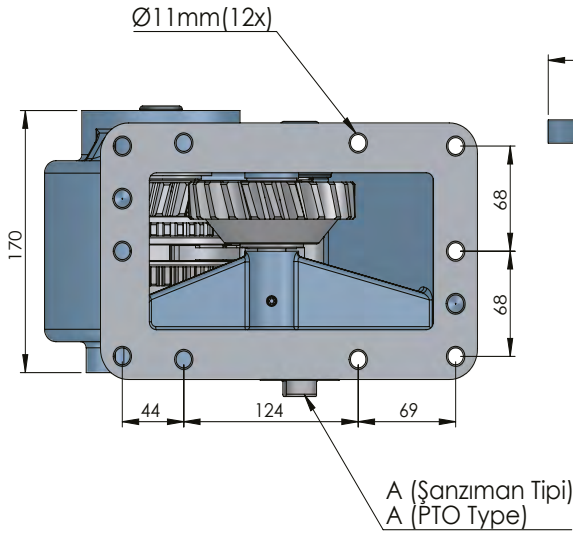
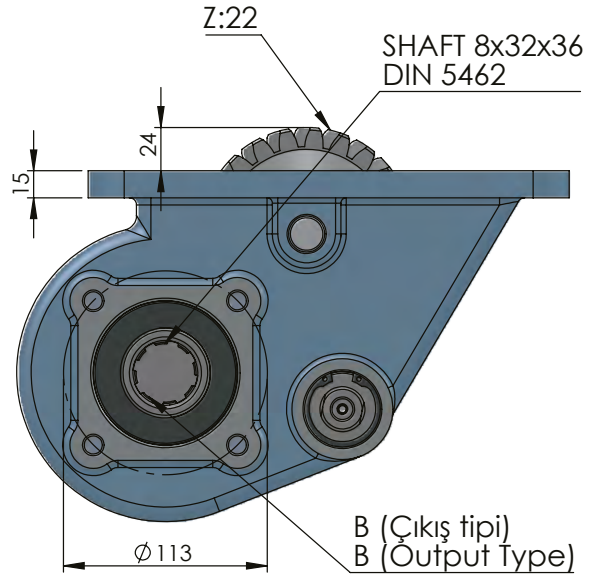

CODE KOD	TYPE TİP (A)	MOUNTING TYPE BAĞLANTI TİPİ (B)	MOUNTING SIDE BAĞLANTI	TORQUE TORK (Kgm / Nm)	POWER GÜÇ (Hp / Kw)	SPEED DEVİR (RPM)	RATIO ORAN
50319512P0	PNEUMATIC PNÖMATİK	UNI ADAPTER ADAPTÖRLÜ UNI	SIDE YAN	26 Kgm 250 Nm	36 Hp 27 Kw	1000 RPM	1:0.95
50319522P0		ISO					
50319532P0		FLANGE ADAPTÖRLÜ FLANŞLI					
50319542P0		SHAFT ADAPTÖRLÜ ŞAFTLI					
GEARBOX / ANA ŞANZIMANLAR				USED VEHICLES / KULLANILAN BAZI ARAÇLAR			
GS 770 - GS 771 - G 670 - GS 750 - GS 760 - GS 770				93-100H-111-112-113R-143P-82 H220-93 HG 230 SCANIA			