

TURNER T5C4060 DOUBLE GEAR UNI

TURNER T5C4060 AKTARMALI UNI

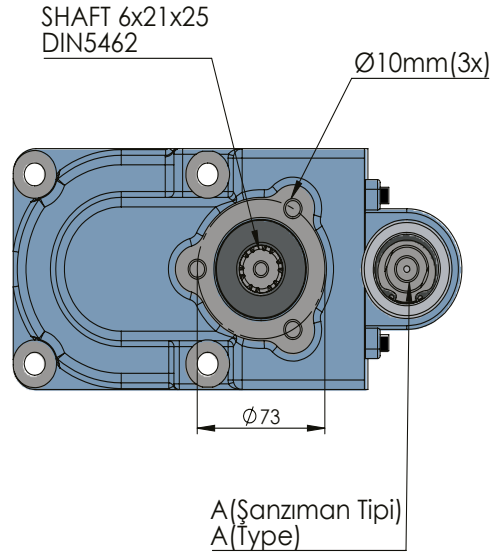
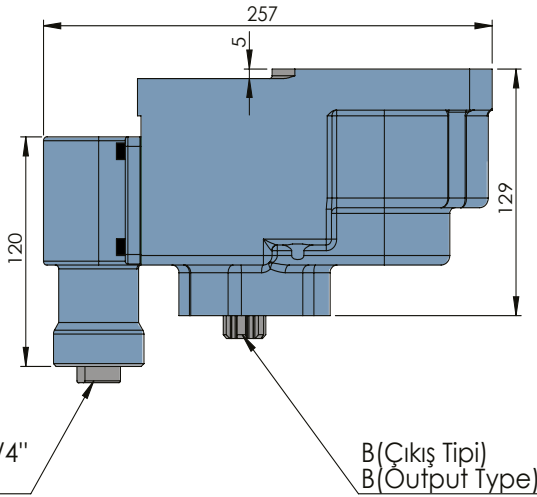
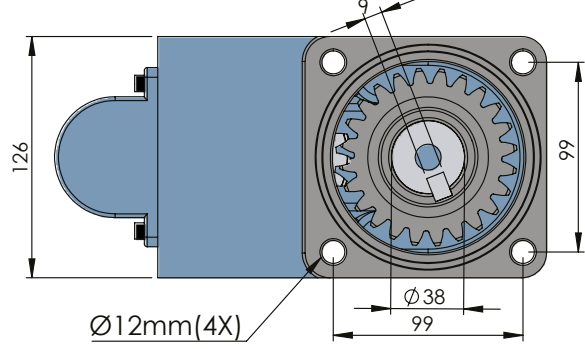

Hava Girişi R1/4"
Air Inlet R1/4"

B (Çıkış Tipi)
B (Output Type)

A (Şanzıman Tipi)
A (Type)

CODE KOD	TYPE TİP (A)	MOUNTING TYPE BAĞLANTI TİPİ (B)	MOUNTING SIDE BAĞLANTI	TORQUE TORK (Kg _m / Nm)	POWER GÜÇ (Hp / Kw)	SPEED DEVİR (RPM)	RATIO ORAN
51012311P0	PNEUMATIC PNÖMATİK	UNI	REAR KUYRUK	24,9 Kg _m 244,2Nm	23,9 Hp 17,8 KW	500 RPM	1.1,2
51012321P0		ISO ADAPTER ADAPTÖRLÜ ISO					
51012331P0		FLANGE FLANŞLI					
51012341P0		SHAFT ŞAFTLI					
GEARBOX / ANA ŞANZIMANLAR				USED VEHICLES / KULLANILAN BAZI ARAÇLAR			
TURNER-SPICER T5 C 4001-4058-4060-4068-4084 R-L				162.22-162.25-170.25 FATİH / YAVUZ 1850-2200 / 700-800-900 DODGE / SÜPER 900 DODGE / 1210 FORD			