

## TURNER T5C4060 SIDE UNI

TURNER T5C4060 YAN UNI

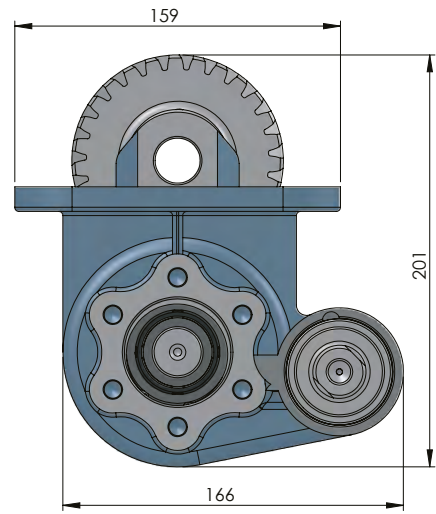
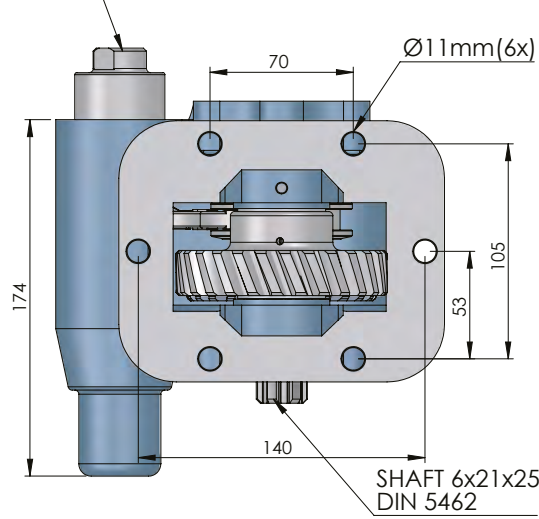
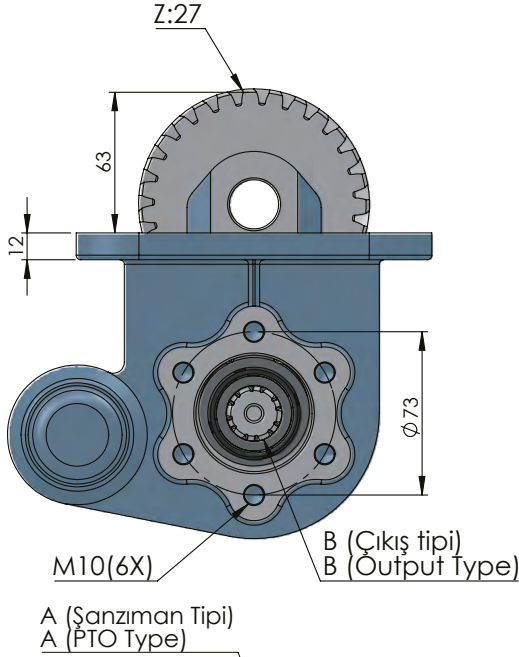

| CODE KOD  | TYPE TİP (A)       | MOUNTING TYPE BAĞLANTI TİPİ (B) | MOUNTING SIDE BAĞLANTI | TORQUE TORK (Kg / Nm)  | POWER GÜÇ (Hp / Kw) | SPEED DEVİR (RPM) | RATIO ORAN |
|---|--------------------|---------------------------------|------------------------|--|---------------------|-------------------|------------|
| 51013511P0                                      | PNEUMATIC PNÖMATİK | UNI                             | SIDE YAN               | 34 Kg<br>333,4 Nm  | 24,5 Hp<br>18,3 KW  | 500 RPM           | 1:1        |
| 51013521P0                                      |                    | ISO ADAPTER ADAPTÖRLÜ ISO       |                        |  |                     |                   |            |
| 51013531P0                                      |                    | FLANGE FLANŞLI                  |                        |  |                     |                   |            |
| 51013541P0                                      |                    | SHAFT ŞAFTLI                    |                        |  |                     |                   |            |
| GEARBOX / ANA ŞANZIMANLAR                       |                    |                                 |                        | USED VEHICLES / KULLANILAN BAZI ARAÇLAR  |                     |                   |            |
| TURNER-SPICER T5 C 4001-4058-4060-4068-4084 R-L |                    |                                 |                        | 162.22-162.25-170.25 FATİH / YAVUZ 1850-2200 / 700-800-900 DODGE / SÜPER 900 DODGE / 1210 FORD |                     |                   |            |