

ZF-6 DOUBLE GEAR UNI

ZF-6 ÇİFT DİŞLİ UNI

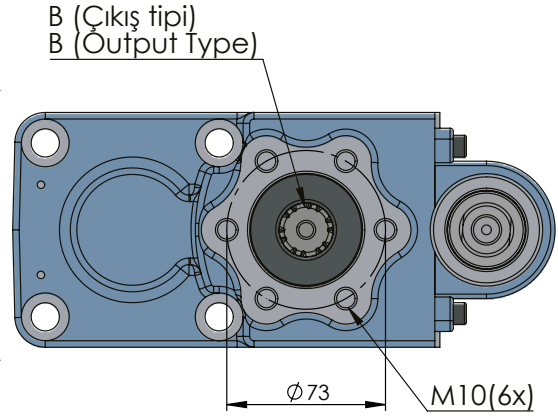
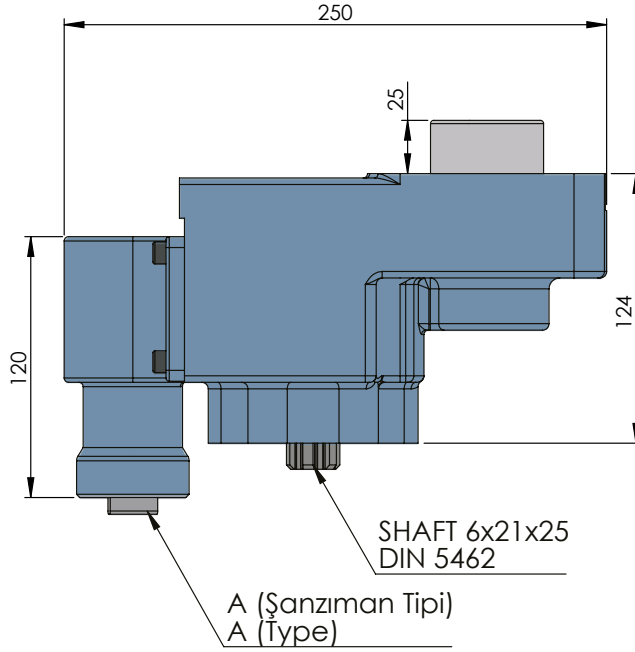
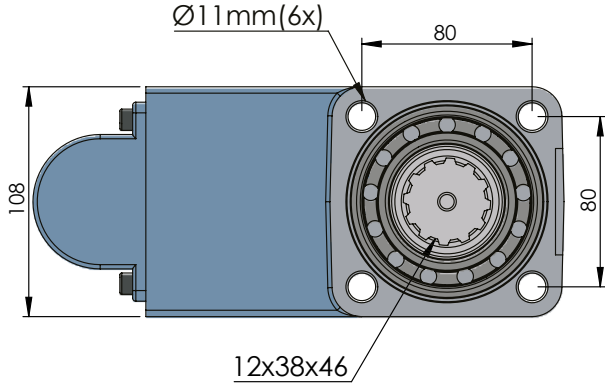

ZF

POWER TAKE-OFFS
P.T.O.

CODE KOD	TYPE TİP (A)	MOUNTING TYPE BAĞLANTI TİPİ (B)	MOUNTING SIDE BAĞLANTI	TORQUE TORK (Kgm / Nm)	POWER GÜÇ (Hp / Kw)	SPEED DEVİR (RPM)	RATIO ORAN
5021151P0	PNEUMATIC PnöMATİK	UNI	REAR KUYRUK	22,4 Kgm 219,7 Nm	20 Hp 14,9 Kw	650	1:1,12
5021152P0		ISO ADAPTER ADAPTÖRLÜ ISO					
5021153P0		FLANGE FLANŞLI					
5021154P0		SHAFT ŞAFTLI					
GEARBOX / ANA ŞANZIMANLAR				USED VEHICLES / KULLANILAN BAZI ARAÇLAR			
ZF44, ZF6S800, ZF6S1000, ZFS635, ZFS642, ZFS650, ZFS655, ZFS665, ZFS670, ZFS680, ZFS690, ZFS550, ZFS590, GV90, VOLVO2855/ZF S5/AK/6S-120-111-110-92 GP ZF S5/AK/ 6S-90-80-70-66-65-55-50-42-36-35 ZF AK 6 80 / AK 6 90 / S6 80 / S6 90				MAN/MERCEDES/BMC PROFESYONEL/FORD CARGO/CHRYSLER HINO/DODGE/FARGO/ HYUNDAI/ASTRAIVECO/DAF/DAEWOO/RENAULT/EBRO/GUY/AVIA/SAURER/SISU/STEYR			